



800 Series – Floodlight Luminaires (Ex n)

ATEX

Models 844, 854, and 864

INSTALLATION, OPERATION AND MAINTENANCE INSTRUCTIONS

Important: Please read these instructions carefully before installing or maintaining this equipment. Good electrical practices should be followed at all times and this data should be used as a guide only.

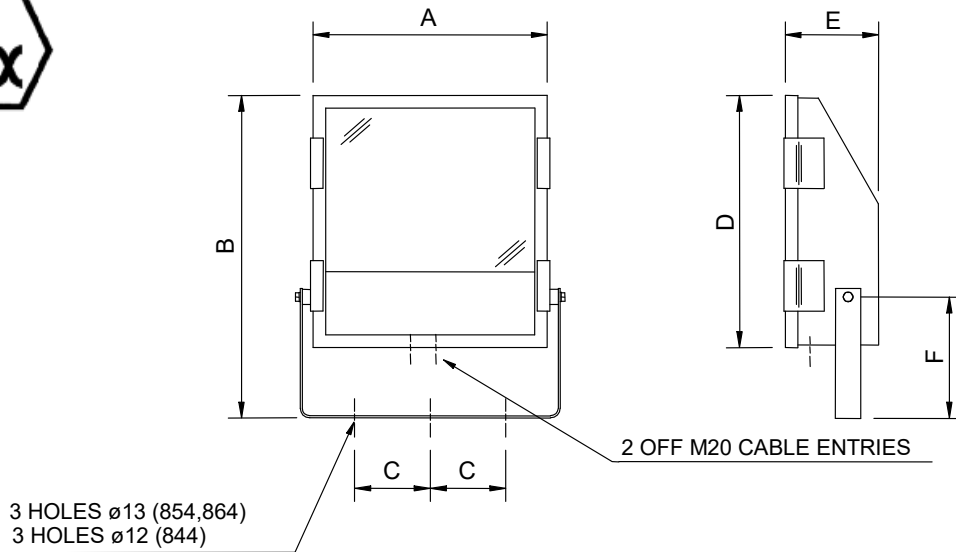

DIMENSIONS	844 70W	854 150/250/400W	864 400W
A	308	415	456
B	443	630	615
C	75	150	150
D	348	490	490
E	150	185	220
F	175	260	250

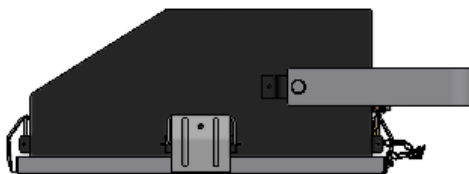

Floodlight Front Face Parallel to Ground

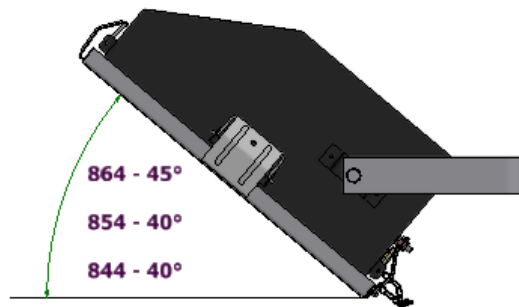

Recommended Maximum Mounting Angles from Horizontal

0.0 Specification	
Type Of Protection	Ex nR (restricted breathing)
Protection Standards	EN 50021, EN 50281-1-1.
Area Classification	Zone 2 areas to EN 60079-10-1, Zone 22 areas to EN 60079-10-2.
Installation	EN 60079-14
Certificate	Type Examination Certificate BAS98ATEX3378
Equipment Coding	Ex nR II T* (T amb see table 1 for details)
ATEX Coding	Ⓜ II 3GD T°C (see table 1)
Ingress Protection	IP66/67 to EN 60529
CE Mark	 <p>The CE marking of this product applies to "The Electrical Equipment (Safety) Regulations 2006", "The Electromagnetic Compatibility Regulations 2004", the "Waste Electrical and Electronic Equipment Regulations 2006" and the "Equipment and Protective Systems intended for use in Explosive Atmospheres Regulations 1996". [This legislation is the equivalent in UK law of EU directives 2014/35/EU, 2014/30/EU, 2012/19/EU and 2014/34/EU respectively].</p> <p>The Equipment is declared to meet the provisions of the ATEX directive (2014/34/EU) by reason of the Type Examination and compliance with the Essential Health and Safety Requirements. M Poutney Technical Manager</p>

SPECIAL CONDITIONS FOR SAFE USE

None

1.0 Introduction – 800 nR Series Floodlights

The type of protection is Ex nR using a restricted breathing enclosure.

The luminaire is restricted in its mounting position - The beam of the floodlight may be aimed at any angle but the control gear must always be mounted on or below the axis of rotation of the luminaire.

2.0 Application

The luminaire is designed to be safe in normal operation.

The luminaire should not be used in conditions where there are environmental, vibration or shock conditions above the normal for fixed installations.

The gaskets should not be exposed to hydrocarbons in liquid or high concentration vapour states.

The luminaire is suitable for applications where *Category 3* apparatus is used. The application is for ignitable gas and dust atmospheres. The type examination does not address suitability for portable applications.

3.0 Installation and Safety

3.1 General

There are no health hazards associated with this product whilst in normal use. However, care should be exercised during the following operations. Installation should be carried out in accordance with BS EN60079-14 or the local hazardous area code of practice, whichever is appropriate.

The luminaires are Class 1 and should be effectively earthed.

Certification details on the rating plate must be verified against the application requirements before installation.

The information in this leaflet is correct at the time of publication. The company reserves the right to make specification changes as required.

3.1.1 Use in Combustible Dust Atmospheres

Where the equipment is used in ignitable dust atmospheres reference must be made to the selection and installation standards in order that the equipment is used correctly. In particular this applies to the de-rating of surface temperature for use where dust clouds may be present. Dust layers should not be allowed to accumulate on the fitting surface and good housekeeping is required for safe operation. Dust in layers has the potential to form ignitable clouds and to burn at lower temperatures.

Refer to EN 60079-10-2 & EN 60079-14 for additional details of selection and installation.



3.1.2 Hybrid Mixtures – Gas and Dust

Where hybrid mixtures exist as a potentially explosive atmosphere, consideration should be given to verifying that the maximum surface temperature of the luminaire is below the ignition temperature of the hybrid mixture.

3.2 Tools

A piece of 6mm bar or a cross head screwdriver blade to open the cover.

19mm A/F spanner, 8mm A/F socket, 3mm and 5mm flat blade screwdriver.

Pliers, knife, wire strippers/cutters.

3.3 Electrical Supplies

The supply voltage and frequency should be specified when ordering a maximum voltage variation of +6%/-6% on the nominal is expected. (The safety limit for T rating is +10%). Luminaires should not be operated continuously at more than +6%/-10% of the rated supply voltage of the control gear or tapping. The user must determine the **actual** underlying site supply and purchase or adjust accordingly. In some cases, the luminaires have multi-tapped control gear which can be set to a range of 50 and 60Hz voltages. The tapplings are shown on the control gear and the limits are shown on the rating plate. If the equipment is located in high or low voltage sections of the system, an appropriate voltage tap should be selected to obtain the best lamp performance, but care must be taken to log or mark the equipment so that the tapping is re-set if the equipment is relocated. If in doubt, tapplings should be set on the high side. If an autotransformer is fitted, the output voltage should be checked and, where appropriate, the tapplings should be adjusted to suit the actual circuit voltage. 10V Max. drop is desirable for HPS and required for MBI. All circuits use S.I.P. (superimposed pulse) ignitors. This means that there are only two connections to the choke, so tap selection is obvious. Where supply conditions include significant harmonics, the PFC can be omitted.

Where shore or construction site supplies are used, which are different to the service location supplies, tapplings should be re-set. If not, advice on the effect of these temporary supplies should be sought from the Technical Department.

3.4 Lamps

The discharge lamps used are of a standardised type. There is no preference between make or colour. The 800 nR series uses tubular HPS and MBI lamps. Care must be taken to fit the correct new and replacement lamps in order to preserve the certification conditions and obtain the designed photometric performance. The lamp type is shown on the rating plate. **Lamps should be replaced shortly after they do not light.** One indication of the end of life for HPS lamps is 'cycling' where the lamp goes out then re-ignites after a minute or so interval. If discharge luminaires are burned continuously, they should be switched off occasionally to allow old lamps to fail to re-ignite, rather than possibly become diodes with detrimental effects to control gear.

The above information is current at the time of preparation. The development of lamps and control gear is ongoing and detailed advice on lamp performance can be obtained from the lamp supplier or from Chalmit.

Important: *HPS and MBI circuits should not be energised without a lamp fitted. HPS and MBI lamps with internal ignitors must not be used.*

3.5 Mounting

Luminaires should be installed where access for maintenance is practical and in accordance with any lighting design information provided for the installation. This will usually consist of aiming points and aiming angles. Recommended maximum aiming angles are indicated in above diagrams to minimize light wastage. The foot mounting or rear mounting arrangements should be secured with lock washers or self-locking nuts and bolts. The luminaire should be mounted with the lamp axis horizontal.

3.6 Cabling and Cable Glands

3.6.1 Cables

The cable entry temperatures are given as the rise over the maximum rated ambient. This allows the user to adjust the cable specification for the actual site maximum temperature. The terminals are suitable for standard conductor section up to 6mm² max. All models are suitable for looping. Standard 300/500V cable is suitable. The cable makeup must be suitable to ensure the obtaining of a restricted breathing enclosure when the cable gland assembly is fitted.

It is strongly advisable to use a high quality and well filled cable with direct entry into restricted breathing luminaires.

3.6.2 Cable Glands

Cable glands and sealing plugs when installed must maintain the restricted breathing enclosure. Entries suitable for M20 cable glands are standard.

To maintain the restricted breathing properties of the enclosure a suitable cable gland such as a **Hawke 501/453/RAC** type should be installed or a cable gland satisfying the following requirements:

- The cable gland must satisfy the requirements for en 60079-0 and must maintain an ingress rating of at least IP65.
- The certified cable gland is to be a compression type gland where the cable sheath is evenly compressed when tightened or an Ex d stuffing type or a punched seal type.
- To enable a reliable seal at the cable entry face a neoprene or silicone rubber washer and a stainless steel washer are provided for each entry and must be fitted.

3.7 Cabling and Fitting Lamps

Access for cabling and fitting lamps is by removing the front cover. Before removing the cover on any occasion, check that the support chain is sound. The cover is released by undoing the six toggle clips using a screwdriver or a peg through the hole in the clip. The reflector is removed by releasing four screws. The baffle plate is removed by undoing the four M5 nuts on the underside. Reselect the voltage tapplings if necessary. Install the conductors in the appropriate terminals. Take care not to cut back the insulation excessively, 1mm bare conductor outside the terminal is a maximum. Any unused terminal should be fully tightened. When the cabling is complete, make a final tightness and connection check. Lamps must be of the correct type and firmly screwed into place. The cover is replaced and the toggle clips snapped back over.

3.8 Inspection and Maintenance

Visual inspection should be carried out at a minimum of 12 monthly intervals and more frequently if conditions are severe. The time between lamp changes could be very infrequent and this is too long a period without inspection.

3.8.1 Routine Examination

The equipment must be de-energised before opening. Individual organisations will have their own procedures. What follows are guidelines based on *EN 60079-17* and on our experience:

- 1 Ensure the lamp is lit when energised and that the lampglass is not damaged.
- 2 When de-energised and left to cool, there should be no significant sign of internal moisture. If there are signs of water ingress, the luminaire should be opened up, dried out, and any likely ingress points eliminated by re-gasketting.
- 3 Check the cable gland for tightness and nip up if necessary.
- 4 Check all cover toggle clips for tightness. If they appear slack, re-set by reducing the angle of the long sides of the clips by bending until they require firm pressure to lock in place.
- 5 Clean the lampglass.
- 6 When relamping, check that the cover gasket has not softened or become excessively deformed, if in doubt replace (*See Section 4.0*).

3.9 Electrical Fault Finding and Replacement

The supply must be isolated before opening the luminaire.

In most instances, the faults are simple, namely loose or broken connections, unserviceable lamps or open circuit control gear. Control gear will not normally go open circuit unless it has first over-heated; the signs of this are obvious, being severe discoloration of the paint on the gear and cracks in any exposed insulation. Similarly, a bad contact at the lamp cap will usually result in discoloration as a sign of overheating.

Any fault finding must be done by a competent electrician and, if carried out with the luminaire in place, under a permit to work. With HPS and MBI, the ignitor can become faulty. If the lamp is fitted, the choke has continuity and the connections are good and correct, they should produce an attempt to start effect in the lamp and a buzzing sound from the ignitor. It will be unusual to have no other parts available to perform a substitution fault finding routine and this is the normal procedure. Before re-assembling, all connections should be checked and any damaged cable replaced. The ignition connection to the lampholder is sleeved with H.T. sleeving and this must be kept in place.

3.9.1 Thermal Protector

Thermal protectors are included. If the lamp goes on and off over a timescale of several minutes, this could be the thermal protector operating. The causes are defective lamps/diode effects, gross over voltage or the choke beginning to fail and this should be investigated directly. Also see Section 3.4.

4.0 Overhaul

The unit is largely made of materials which are very corrosion resistant. This allows the unit to be completely stripped, cleaned, then re-built with new electrical parts as required. The internal wiring is 1.0mm² flexible, silicone rubber insulated. An H.T. sleeve is fitted to the ignitor cable. All the spares required are available. Please state the model number, lamp and reflector details.

The seal at the cover is between the glass and the body. The glass is retained in the cover frame by silicone R.T.V. adhesive.

If the cover gasket has deteriorated by softening or permanent set, a new cover assembly should be fitted, which can be obtained from Chalmit.

5.0 Fuse Ratings

The fuse ratings for HID lamp circuits need to take account of three components of circuit current. Current inrush to PFC capacitors which can be up to 25 x the rated capacitor current and last 1-2 milliseconds; lamp starting current including steady capacitor current which together may decline from up to 200% of normal at 10 seconds after switch-on to normal after 4 minutes; rectification effects caused by asymmetrical cathode heating for a few seconds after starting, this effect is random and very variable. With the availability of MCB's with a wide range of characteristics, the individual engineer can make a better judgement of what is required. Use MCB's suitable for inrush currents to reduce ratings. The inrush current can be calculated where circuit conditions are known. The nominal capacitor current will probably be the determining factor, 0.076A per μ F at 240V, 50Hz (adjust for other supply volts by multiplication, x 6/5 for 60Hz). For HBC fuses use 1.5 x normal capacitor current. All calculations must satisfy wiring regulations.

6.0 Disposal of Material

The unit is mostly made from incombustible materials. The capacitor is of the dry film type and does not contain PCB's. The control gear contains plastic parts and polyester resin. The ignitor contains electronic components and synthetic resins. All electrical components and the body parts may give off noxious fumes if incinerated. Take care to render these fumes harmless or avoid inhalation. Any local regulations concerning disposal must be complied with. Any disposal must satisfy the requirements of the [WEEE directive \[2012/19/EU\]](#) and therefore must not be treated as commercial waste. The unit is mainly made from incombustible materials. The control gear contains plastic, resin and electronic components. All electrical components may give off noxious fumes if incinerated.

6.1 Lamps

Incandescent lamps and discharge lamps in modest quantities are not "special waste". The outer envelope should be broken in a container to avoid possible injury from fragmentation.

Any local regulations concerning disposal must be complied with.

Important: *Do not incinerate lamps.*



To comply with the Waste Electrical and Electronic Equipment directive 2012/19/EU the apparatus cannot be classified as commercial waste and as such must be disposed of or recycled in such a manner as to reduce the environmental impact.



Model	Wattage	Lamp	Min Amb °C	Max Amb °C	T Rating	Max Surface Temp °C	Cable Temp Rise °C	Cable Rating °C	VA Rating (When fitted with Autotransformer)
844	70W	SON/T	-30	50	T3(150°C)	150	25	75	500VA
				40		135		65	
854	100W	SON/T	-30	55	T4	135	20	75	
		SON/T	-30	50		135		70	
	150W	MBI/T	-25	55	T3	200		75	
		SON/T	-30	40	T4	135		25	
250W	MBI/T	-25	40	135					
854*	400W	SON/T	-30	40	T3	200	35	75	
		MBI/T	-25			200			
864	250W	SON/T	-40	55	T3	200	30	85	
		MBI/T	-25			200			
	400W	MBI/T	-25	45		200		80	
		SON/T	-30	50		200			
864**	150W	SON/T	-30	55	T3	200	20	75	
	250W					200			
	400W					200			30

Note: * 400W 854 version is used in conjunction with an external gearbox.
 ** These models have a 110V or a 120V supply..

Table 2 Lamp, Starting and Running Currents (240V, 50Hz)

Lamp	Lamp Current	Start Current	Running Current	PFC µF	Circuit Power
70W	0.98	0.6	0.45	10	76
100W	1.2	1.0	0.56	10	114
150W	1.8	1.2	0.75	20	168
250W	3.0	2.65	1.35	30	282
400W	4.6	4.0	2.2	40	445

Table 3 Lamp, Starting and Running Currents (120V, 50Hz)

Lamp	Lamp A	Start A	Running A	PFC µF	Circuit Power
150W	1.8	2.4	1.5	20	170
250W	3.0	5.3	2.7	30	290
400W	4.6	8.0	4.4	40	450

Table 4 Fuse Ratings



Lamp Wattage	Number of Lamps					
	1	2	3	4	5	6
70W	4A	6A	10A	10A	16A	16A
100W	4A	6A	10A	10A	16A	16A
150W	4A	6A	10A	10A	16A	16A
250W	10A	16A	16A	20A	20A	20A
400W	16A	20A	20A	25A	25A	32A

Table 5 Weights and Windages

Model	844/70	854/100	854/150	854/250	864/250	864/400
Weight	12.0kg	16.5kg	17.0kg	18.0kg	18.0kg	18.5kg
Windage	0.11m ²	0.20m ²	0.20m ²	0.20m ²	0.22m ²	0.22m ²



- Power factor** ≥ 0.85
- EMC** EN 55015
- Terminals** 6mm² as standard, through wiring and looping has current limit of 16A.
- Tamb Storage** -40°C to +80°C
- Storage** Luminaires should be stored in cool dry conditions preventing ingress of moisture and condensation
- Lamps** Lamps with an E27 or E40 cap in accordance with EN 60238,
- Fuse and section** Refer to tables 2, 3 & 4 for starting and running currents and fuse ratings. Also refer to
- MCB ratings** 3.3.1 for information regarding inrush current.

Chalmit Lighting is a leading supplier of Hazardous Area lighting products

	CHALMIT LIGHTING PO Box 5575 Glasgow, G52 9AP Scotland	
Telephone: +44 (0) 141 882 5555 Fax: +44 (0) 141 883 3704 Email: info@chalmit.com Web: www.chalmit.com	Registered No: 669157 Registered Office: Cannon Place 78 Cannon Street London EC4N 6AF UK	

For technical support, please contact: techsupport@chalmit.com

Note: Chalmit Lighting reserves the right to amend characteristics of our products and all data is for guidance only.

	EU-Declaration of conformity		
	UE-Déclaration de conformité		
	EU-Konformitätserklärung		
Manufacturer	Chalmit	Address	388 Hillington Road, Glasgow. G52 4BL Scotland UK
Product	800 Series Floodlight Luminaires.		
Type Examination Certificate	BAS98ATEX3378		
Notified Body	SGS FIMKO OY 0598		
ATEX Coding	 II 3 GD	ATEX Classification	Group II Category 3 GD
Equipment Coding	Ex nR II T* T°C		
Ingress Protection	IP66/67		
The technical basis, with respect to equivalence of			
La base technique, en ce qui concerne l'équivalence de			
Die technische Grundlage hinsichtlich der Normen			
Protection Standards EN 50021, EN 50281-1-1.			
Area Classification EN 60079-10-1, EN 60079-10-2.			
of compliance with the EHSRs is valid as there are no changes which materially affect the state of technological progress of the product.			
en conformité avec les EESS est valide puisqu'il n'y a aucun changement qui affecte matériellement l'état de l'évolution technologique du produit.			
zur Erfüllung der GSGA ist gegeben, da keine Änderungen erfolgt sind, die einen Einfluss auf den technischen Stand des Produkts haben.			
Terms of the directive:		Standard & Date Certified to	Standards Date Declared to
Prescription de la directive:		Standard & date certifiée à	Normes date Déclaré
Bestimmungen der Richtlinie:		Standard & Datum Zertifiziert nach	Standards Datum erklärt
2014/34/EU	Equipment and protective systems intended for use in potentially explosive atmospheres.	EN 50021: 1999 EN 50281-1-1: 1999	
2014/34/UE	Appareils et les systèmes de protection destinés à être utilisés en atmosphères potentiellement explosibles.		
2014/34/EU	Geräte und Schutzsysteme zur bestimmungsgemäßen Verwendung in explosionsfähigen Bereichen.		
2014/30/EU	Electromagnetic compatibility	EN 55015 : 2013	
2014/30/UE	Compatibilité électromagnétique	EN 61547 : 2009	
2014/30/EU	Elektromagnetische Verträglichkeit	EN 61000-3-2 : 2014	
2014/35/EU	Low voltage equipment	EN 60598-1 : 2015	
2014/35/UE	Équipements électriques à bas voltage	EN 60529 : 1992	
2014/35/EU	Niederspannungsgeräte / -systeme	EN 60598-2-5 : 2015	
2012/19/EU	Waste of electrical and electronic equipment		
2012/19/UE	Déchets d'équipements électriques et électroniques		
2012/19/EU	Entsorgung der elektrischen und elektronischen Geräte / Systeme		
2011/65/EU	RoHS II Directive		



On behalf of the Chalmit, I declare that, on the date the equipment accompanied by this declaration is placed on the market, the equipment conforms to all technical and regulatory requirements of the above listed directives.

En tant que représentant du fabricant Chalmit, je déclare qu'à la date où les équipements accompagnant cette déclaration sont mis sur le marché, ceux-ci sont conformes à toutes les dispositions réglementaires et techniques des directives énumérées ci-dessus.

Hiermit bestätige ich, im Namen von Chalmit, dass am Tag der Lieferung des Produkts/der Produkte zusammen mit dieser Erklärung das Gerät/die Geräte alle technischen und regulativen Anforderungen der oben aufgeführten Direktiven erfüllt.

Name and Date Mark Poutney 04/02/2021
Nom et Date
Name und Datum

Technical Manager
Directeur technique
Technischer Leiter

Quality Assurance Notification by: **SGS FIMKO OY**
Notification d'assurance qualité par: **0598**
Qualitätssicherungsnotifikation durch:

Quality Management System Accreditation:
Système de Management Qualité Accréditation:
Qualitätsmanagementsystem Akkreditierung:
Environmental Management System.
Système de gestion de l'environnement.
Umwelt kontroll system.
Certificate No./Certificat N°/Zertifikat Nr.

ISO 9001
ISO 14001
by/par/durch
Lloyd's Register
LRQ 4005876