

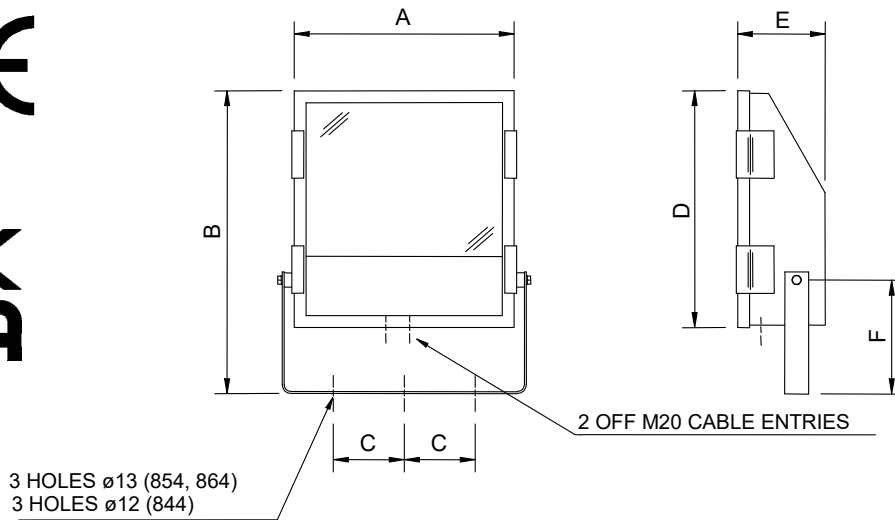

INSTALLATION, OPERATION AND MAINTENANCE INSTRUCTIONS

800 Series - Stainless Steel Floodlight Luminaires *Industrial Models 844I, 854I, & 864I*

Important: Please read these instructions carefully before installing or maintaining this equipment. Good electrical practices should be followed at all times and this data should be used as a guide only.



DIMENSIONS	844I 70/100W	854I 150/250/400W	864I 400/600W
A	308	415	465
B	443	630	615
C	75	150	150
D	348	490	500
E	175	185	190
F	175	260	250

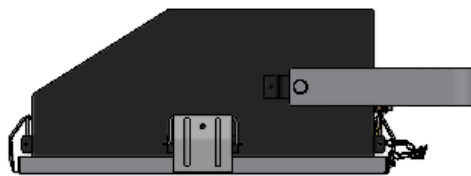

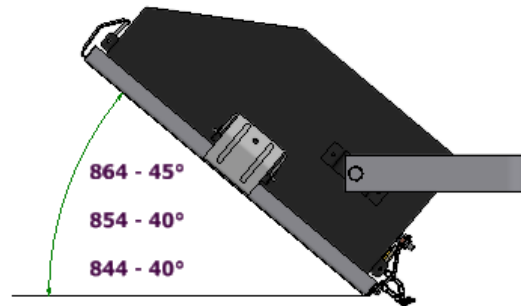

Floodlight Front Face Parallel to Ground



Recommended Maximum Mounting Angles from Horizontal



0.0 Specification	
Type Of Protection	N/A
Standards	EN 60598-1
Area Classification	Industrial (Non- Hazardous).
Ambient	see table 1
Ingress Protection	IP66/67 to EN 60529
 	<p>The CE marking of this product applies to "The Electrical Equipment (Safety) Regulations 2006", "The Electromagnetic Compatibility Regulations 2004", the "Waste Electrical and Electronic Equipment Regulations 2006". [This legislation is the equivalent in UK law of EU directives 2014/35/EU, 2014/30/EU, 2012/19/EU respectively].</p> <p>The UKCA marking of this product applies to "The Electrical Equipment (Safety) Regulations 2016", "The Electromagnetic Compatibility Regulations 2016", the "Waste Electrical and Electronic Equipment Regulations 2012</p> <p>M Poutney Technical Manager</p>

1.0 Introduction – 800 Series Stainless Steel Floodlight

The type 844I, 854I and 864I floodlights are manufactured in marine grade 316 stainless steel and are designed for use in marine or hostile environments. The maximum recommended operating ambient (tamb) is 40°C for indoors or still air and 55°C for outdoors or where situated in free moving air.

Note: *All the floodlights in this series are suitable for tubular lamps only.
The range of models is outlined in TABLE 0.*

2.0 Storage

Luminaires and control gear boxes are to be stored in cool dry conditions preventing ingress of moisture and condensation. Any specific instructions concerning emergency luminaires must be complied with.

3.0 Installation and Safety

3.1 General

Installation must be made in accordance with good electrical procedure and local codes of practice. In the UK the requirements of the "Health and Safety at Work Act" and "The Electricity at Work Act" must be met. The luminaires are Class 1 and should be effectively earthed. The luminaires are heavy and suitable handling equipment must be employed during installation.

3.2 Tools

Suitable spanners for installing cable glands, 3mm and 5mm flat blade screwdriver.
Pliers, knife, wire strippers/cutters.

3.3 Electrical Supplies

The supply voltage and frequency should be specified when ordering. A maximum voltage variation of +6%/-6% on the nominal is expected. In some cases, the luminaires have multi-tapped control gear which can be set to a range of 50 and 60Hz and voltages of 220, 230, 240, and 254V AC. 120V AC option available with transformer. The tapplings are shown on the control gear and the limits are shown on the rating plate. If the equipment is located in the high or low voltage sections of the system, an appropriate voltage tap should be selected, but care must be taken to log or mark the equipment so that the tapping is re-set if the equipment is relocated. If in doubt, tapplings should be set on the high side.
10V Max drop is desirable for HPS and advised for MBI. All the HPS and MBI circuits use SIP (superimposed pulse) ignitors. This means that there are only two connections to the choke making the tap selection obvious. Where shore or construction site supplies are different to the service locations supplies used, tapplings should be re-set. If not, advice on the affect of these temporary supplies should be sought from the Chalmit Technical Department.



3.4 Mounting

Luminaires should be installed where access for maintenance is practical and in accordance with any lighting design information provided for the installation. The foot mounting or rear mounting arrangements should be secured with lock washers or self-locking nuts and bolts. The luminaire should be mounted with the lamp axis horizontal. Recommended maximum aiming angles are indicated in above diagrams to minimize light wastage. The luminaire should not be mounted with the gear positioned above the lamp if at all possible.

Note: *The weights of the various models are indicated in TABLE 0.*

3.5 Lamps

The high pressure sodium lamps are of a standardised type. There is no preference between make or colour. The 844I model has an E27 lampholder, the 854I and 864I models have an E40 lampholder.

MBI lamps are not standardised in the 250W and 400W range. For MBI the 3.0A 250W lamp and the 4.2A 400W lamp is used.

Only tubular lamps should be used. Both specular (plain) and dispersive (mottled) reflectors are available for all luminaires and should be specified when ordering.

Anti-glare shields are available for all types but must be ordered with the equipment, as the fixings are not standard. Care must be taken to fit the correct lamp in order to obtain the designed photometric performance.

HPS and MBI lamps should be replaced shortly after they do not light. The indication of the end of life for HPS lamps is "cycling", where the lamps goes out then re-ignites after a minute or so interval. If discharge luminaires are burned continuously, they should be switched off occasionally to allow old lamps to fail to re-ignite, rather than possibly becoming diodes with possible detrimental effects to control gear. The above information is current at time of printing. The development of lamps and control gear is ongoing and detailed advice on lamp performance can be obtained from the lamp supplier or from Chalmit. HPS and MBI circuits should not be energised without a lamp fitted. HPS and MBI lamps with internal ignitors must not be used.

3.6 Cabling and Cable Glands

The temperature conditions of the supply cable entry point are such that 70°C (ordinary PVC) cable can be used in all the standard range luminaires. The maximum looping size is 2.5mm² with 6mm² single entry as standard. Two entry points capable of accepting 20mm Ø glands are standard. It is the responsibility of the user to ensure that the correct cable size and fuse rating are used.

Cable glands where installed should maintain the IP rating of the luminaire and if using metal glands, should be of suitable material or suitably protected to meet any prevailing environmental conditions. Plastic glands may be used except in cases where the earth is provided by means of the cable armour in which case a suitable metal gland should be employed. Care should be taken to ensure that a good contact is made between the gland and the body of the luminaire.

It is the responsibility of the user to ensure that an adequate seal is made between the gland and the body to maintain the IP rating.

3.7 Cabling and Fitting Lamps

Access for cabling and fitting lamps is by removing the front cover. Before removing the cover on any occasion, check that the cover support chain is sound.

The cover is released by undoing the two toggle clips using a screwdriver or a peg through the hole in the clip. Reselect the voltage tappings if necessary.

Install the conductors in the appropriate terminals. Take care not to cut back the insulation excessively, 1mm bare conductor outside the terminal is a maximum.

Any unused terminal should be fully tightened.

When the cabling is complete, make a final tightness and connection check.

Lamps must be of the correct type and firmly screwed into place. The cover is replaced and the toggle clips snapped over.

3.8 Inspection and Maintenance

Routine inspection should be carried out at a minimum of 12 monthly intervals and more frequently if conditions are severe. The time between lamp changes could be very infrequent and this is too long a period without inspection.



3.8.1 Routine Examination

The equipment must be de-energised before maintenance. Individual organisations will have their own procedures. What follows are guidelines based on Chalmit's experience :

- 1 Ensure the lamp is lit when energised and that the lampglass is not damaged.
- 2 When de-energised and left to cool there should be no significant sign of internal moisture. If there are signs of water ingress, the luminaire should be opened up, dried out, and any likely ingress points eliminated by re-gasketing.
- 3 Check all cable glands for tightness and nip up if necessary.
- 4 Check all cover toggle clips for tightness. If they appear slack, re-set by bending the angle between the long sides of the clips until they require firm pressure to lock into place.
- 5 Clean the lampglass.

3.9 Electrical Fault Finding and Replacement

Control gear will not normally go open circuit unless it has first overheated; the signs of this are obvious, being severe discoloration of the paint of the gear and cracks in any exposed insulation. Similarly, a bad contact at the lamp cap will usually result in discoloration as a sign of overheating.

Any fault finding must be carried out by a competent electrician. With HPS the ignitor can become faulty. If the lamp is fitted, the choke has continuity and the connections are good and correct, they should produce an attempt to start effect in the lamp and a buzzing sound from the ignitor.

It will be unusual not to have other parts available to perform a substitution fault finding routine and this is the normal procedure. Before re-assembling, all connections should be checked and any damaged cable replaced. The ignition connection to the lampholder is sleeved with H.T. sleeving and this must be kept in place.

4.0 Overhaul

The unit is largely made of material which are very corrosion resistant. This allows the unit to be completely stripped, mechanically cleaned, then re-built with new electrical parts as required. The internal wiring is 1.0mm² flexible, silicone rubber insulated. If the cover gasket has deteriorated by softening or permanent set, a new cover assembly should be fitted, all components can be obtained from Chalmit.

5.0 Fuse Ratings

The fuse ratings for HID lamp circuits need to take account of three components of circuit current. Current inrush to PFC capacitors which can be up to 25x the rated capacitor current and last 1-2 millisecs; lamp starting current including steady capacitor current which together may decline from up to 200% of normal at 10 seconds after switch on to normal after 4 minutes; rectification effects caused by asymmetrical cathode heating for a few seconds after starting, this effect is random and very variable. With the availability of MCBs with a wide range of characteristics, the individual engineer can make a better judgement of what is required. The normal capacitor current will probably be the determining factor 0.076A per μ F at 240V, 50Hz (adjust for other volts by multiplication, x 6/5 for 60Hz). For HBC fuses use 1.5 x normal capacitor current.

All calculations must satisfy wiring regulations.

Note: *Starting and running currents for 240V, 50Hz are as indicated in TABLE 1.
A conventional matrix for HBC fuses is outlined in TABLE 2.*

6.0 Disposal of Material

The unit is made chiefly from inert incombustible materials. The capacitor is of the dry film type and does not contain PCB's. The control gear contains plastic parts and polyester resin. The ignitor contains electronic components and synthetic resins. All the electrical components may give off noxious fumes if incinerated. Care must be taken to render these fumes harmless or avoid inhalation. Any local regulations concerning disposal must be complied with. Any disposal must satisfy the requirements of the WEEE directive [2012/19/EU and Regulations 2012] and therefore must not be treated as commercial waste. The unit is mainly made from incombustible materials. The control gear contains plastic, resin and electronic components. All electrical components may give off noxious fumes if incinerated.

6.1 Lamps

Discharge lamps in modest quantities are not "special waste". The outer envelope should be broken in the container to avoid injury.

This applies to the UK, there may be other regulations on disposal operating in other countries.

Important: Do not incinerate lamps.



To comply with the Waste Electrical and Electronic Equipment directive 2012/19/EU and Regulations 2012 the apparatus cannot be classified as commercial waste and as such must be disposed of or recycled in such a manner as to reduce the environmental impact.

Table 0 Ratings

Refer to Section : 1.0

Model	Lamp Type	Weight kg
844I	70W SON/T & MBI-T	10
854I	100W SON/T	21
	150W SON/T	22
	250W SON/T & MBI-T	23
	400W SON/T*	20
864I	400W SON/T & MBI-T	26
	600W SON/T	23

* Ignitor only fitted. Remote gear box required.

Table 1 Starting and Running Currents

Refer to Section : 5.0

Lamp	Start A		Run A		Capacitance μF	Circuit Power (W)
	240V	120V	240V	120V		
70W HPS	0.55		0.4		10	80
100W HPS	1.0		0.56		10	117
150W HPS	1.45	2.9	0.8	1.6	20	175
250W HPS	2.35	4.7	1.3	2.6	30	285
400W HPS	4.0	8.0	2.2	4.4	40	445
600W HPS	5.6		3.1		60	645
150W MBI	1.6	3.2	0.8	1.6	20	175
250W MBI	2.7	5.4	1.35	2.7	30	285
400W MBI	4.0	8.0	2.2	4.4	40	445

Table 2 Fuse Ratings

Refer to Section : 5.0

Lamp Wattage	Number of Lamps					
	1	2	3	4	5	6
70W	4A	4A	4A	4A	4A	4A
100W	4A	4A	6A	10A	10A	10A
150W	4A	6A	10A	10A	16A	16A
250W	10A	16A	16A	20A	20A	20A
400W	16A	20A	20A	25A	25A	32A
600W	16A	20A	25A	32A	32A	40A

Note: Minimum Power Correction Factor: 0.85



Catalogue Ref	Lamp/Gear & Voltage	Operating Temperature T amb
844I/070/MS	70W Internal Gear & 220-254V	-30°C to +50°C
854I/100/MS	100W Internal Gear & 220-254V	-30°C to +55°C
854I/150/MS	150W Internal Gear & 220-254V	-30°C to +55°C
854I/250/MS	250W Internal Gear & 220-254V	-30°C to +40°C
854I/400/MS	400W Ignitor only, Remote Gear & 220-254V	-30°C to +45°C
864I/400/MS	400W Internal Gear & 220-254V	-30°C to +45°C
864I/600/MS	600W Ignitor only Remote Gear & 220-254V	-30°C to +45°C
864I/150/MS	150W Internal Gear & 110-130	-30°C to +55°C
864I/250/MS	250W Internal Gear & 110-130V	-30°C to +55°C
864I/400/MS	400W Remote Transformer Box & 110-130V	-30°C to +55°C
864I/250/MS/HT	250W Internal Gear & 220-254V	-30°C to +55°C
864I/400/MS/HT	250W Internal Gear & 220-254V	-30°C to +52°C

Chalmit Lighting is a leading supplier of Hazardous Area lighting products

	CHALMIT LIGHTING PO Box 5575 Glasgow, G52 9AP Scotland	
Telephone: +44 (0) 141 882 5555 Fax: +44 (0) 141 883 3704 Email: info@chalmit.com Web: www.chalmit.com	Registered No: 669157 Registered Office: Cannon Place 78 Cannon Street London EC4N 6AF UK	

For technical support, please contact: techsupport@chalmit.com

Note: Chalmit Lighting reserves the right to amend characteristics of our products and all data is for guidance only.



	EU/UK-Declaration of conformity		
	UE-Déclaration de conformité		
	EU-Konformitätserklärung		
Manufacturer	Chalmit	Address	388 Hillington Road, Glasgow. G52 4BL Scotland UK
Product	800 Series Floodlight Industrial (844I, 854I, 864I)		
Catalogue	8**I/***/**	Example: 864I/400/MS/	
Area Classification	Industrial (Non- Hazardous).		
Ingress Protection	IP66/67		
Ambient	-30°C to +**°C (see Table 1)		
Terms of the directive:		Standard & Date Certified to	Standards Date Declared to
Prescription de la directive:		Standard & date certifiée à	Normes date Déclaré
Bestimmungen der Richtlinie:		Standard & Datum Zertifiziert nach	Standards Datum erklärt
2014/30/EU Regulations 2016	Electromagnetic compatibility	EN 55015 : 2019	
2014/30/UE	Compatibilité électromagnétique	EN 61547 : 2009	
2014/30/EU	Elektromagnetische Verträglichkeit	EN 61000-3-2 : 2019	
2014/35/EU Regulations 2016	Low voltage equipment	EN 60598-1 : 2015	
2014/35/UE	Équipements électriques à bas voltage	EN 60598-2-5 : 2015	
2014/35/EU	Niederspannungsgeräte / -systeme	EN 60529 : 1992+A2:2013	
2012/19/EU Regulations 2012	Waste of electrical and electronic equipment		
2012/19/UE	Déchets d'équipements électriques et électroniques		
2012/19/EU	Entsorgung der elektrischen und elektronischen Geräte / Systeme		
2011/65/EU Regulations 2012	RoHS II Directive		

On behalf of the Chalmit, I declare that, on the date the equipment accompanied by this declaration is placed on the market, the equipment conforms to all technical and regulatory requirements of the above listed directives.

En tant que représentant du fabricant Chalmit, je déclare qu'à la date où les équipements accompagnant cette déclaration sont mis sur le marché, ceux-ci sont conformes à toutes les dispositions réglementaires et techniques des directives énumérées ci-dessus.

Hiermit bestätige ich, im Namen von Chalmit, dass am Tag der Lieferung des Produkts/der Produkte zusammen mit dieser Erklärung das Gerät/die Geräte alle technischen und regulativen Anforderungen der oben aufgeführten Direktiven erfüllt.

Name and Date Mark Poutney 04/08/2021
Nom et Date
Name und Datum

Technical Manager
Directeur technique
Technischer Leiter

Quality Management System Accreditation:
Système de Management Qualité Accréditation:
Qualitätsmanagementsystem Akkreditierung:
Environmental Management System.
Système de gestion de l'environnement.
Umwelt kontroll system.
Certificate No./Certificat N°/Zertifikat Nr.

ISO 9001
ISO 14001
by/par/durch
Lloyd's Register
LRQ 4005876