

# Curie - Recessed LED Luminaires

## Industrial

### INSTALLATION, OPERATION AND MAINTENANCE INSTRUCTIONS

**Important:** Please read these instructions carefully before installing or maintaining this equipment. Good electrical practices should be followed at all times and this data should be used as a guide only.

#### Curie Industrial Modular Exposed 'T' and Spring 'T' (/MES) Ceiling

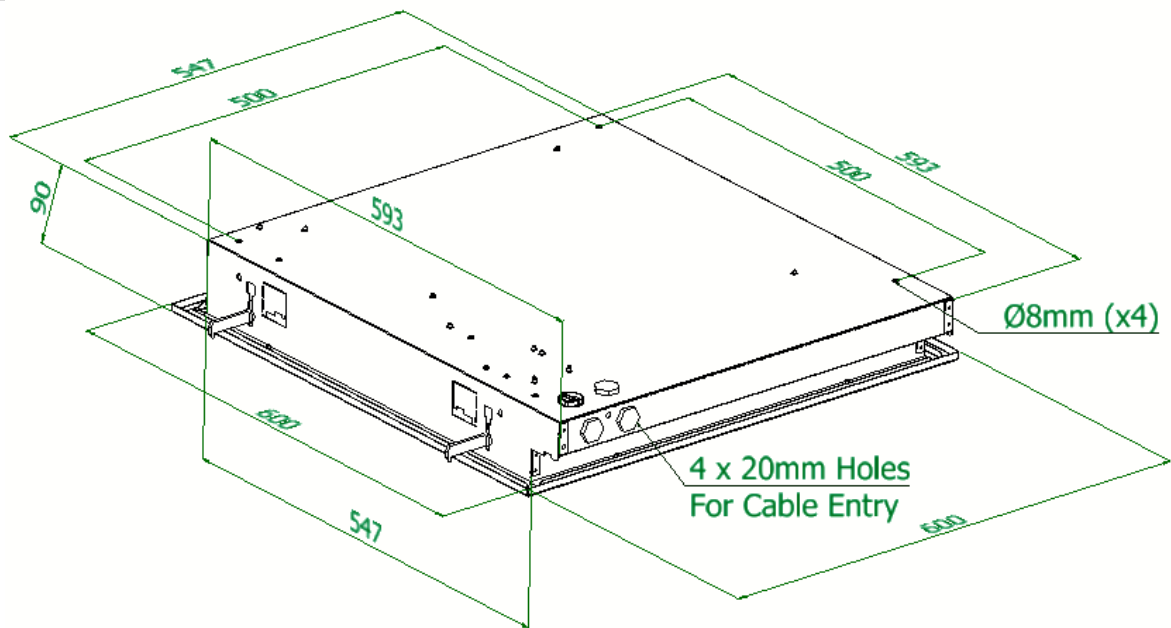

#### Curie Industrial Non-Modular Solid Ceiling

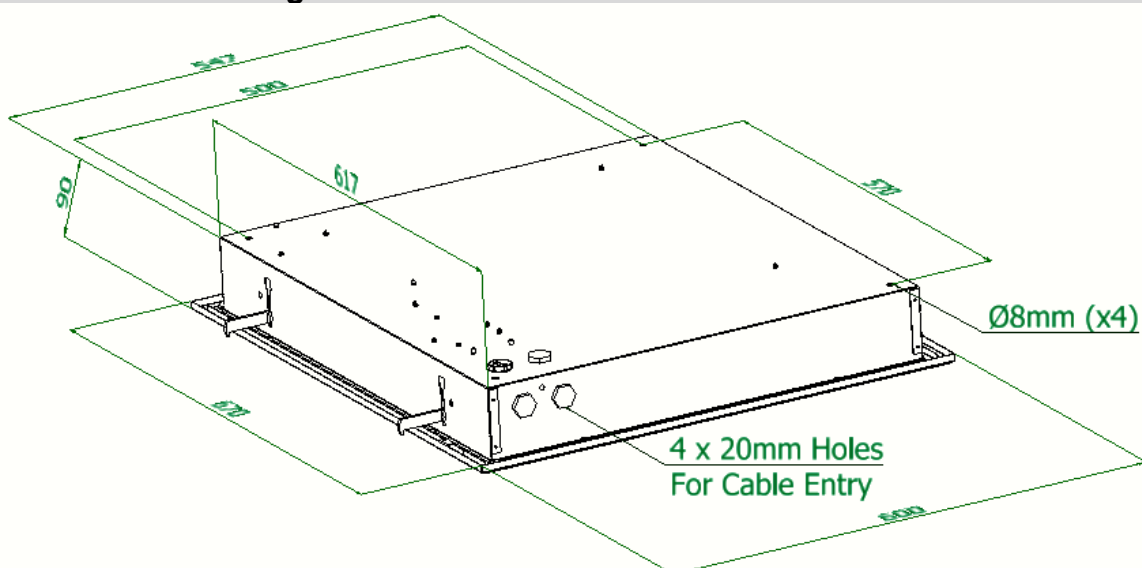



<b>0.0 Specification</b>	
Type Of Protection	N/A
Standards	EN 60598-1, EN 60598-2-22
Area Classification	Non- Hazardous
Ambient	-20°C to 45°C (Non Emergency), -20°C to 40°C (Emergency)
Ingress Protection	IP20 & IP44 (Front Cover Only) to EN 60529
CE Mark 	The CE marking of this product applies to "The Electrical Equipment (Safety) Regulations 2006", "The Electromagnetic Compatibility Regulations 2004", the "Waste Electrical and Electronic Equipment Regulations 2006". [This legislation is the equivalent in UK law of EU directives 2014/35/EU, 2014/30/EU, 2012/19/EU respectively].  M Poutney Technical Manager

**Table 0 - Series Circuit.**

Catalogue code	Gear Type	No. Off LED Strips	Nominal Circuit Power W (max)	Line Current
CURI/03L/LE	LED Driver	3	37	0.170
CURI/04L/LE		4	49	0.220
CURI/03L/LE/EM		3	39	0.183
CURI/04L/LE/EM		4	52	0.246

**Emergency Version Luminaire is supplied with Battery plug/Socket disconnected, just prior to switching power on connect battery plug and socket.**

Emergency versions – Emergency products with internal Ni-Cad battery packs should not be stored for longer than one year without being connected to mains power to allow battery charging to take place. Emergency products ship from the factory with the battery plug and socket disconnected. See section 3.8.2 for further information.

**1.0 Introduction - CURIE Industrial Area Recessible LED Luminaire**

The Curie Industrial series is available as modular and non-modular recessed luminaire for use with LED Lighting with the facility of an internal battery back up for emergency use. The non-modular is suitable for cut or prepared aperture ceilings.

Normal operation is mains supply with all LED's on, switching to reduced Lumen output on battery back up and having local switching of the mains Lighting, the emergency Lumen output only being energised on mains failure.

The luminaires are available in 3000 Lumen, 4000 Lumen for Modular and Non Modular Ceilings.

**2.0 Storage**

Luminaires are to be stored in cool dry conditions preventing ingress of moisture and condensation. Battery packs should not be stored for longer than a year, if stored longer the battery pack should be charged, as per instructions below. Always disconnect battery plug and socket for storage.

**3.0 Installation and Safety**

**3.1 General**

There are no health hazards associated with this product whilst in normal use. However, care should be exercised during the following operations. Installation should be carried out in accordance with any applicable code of practice or regulations and fitting of specified insulating material is to be adhered too where a specific fire resistance rating is required. In the UK, the

requirements of the "Health & Safety at Work Act 1974" and "Electricity at Work Regulations 1989" must be met. The luminaires are Class 1 and should be effectively earthed.

Application details on the rating plate must be verified against the requirements before installation.

The information in this leaflet is correct at the time of publication. The company reserves the right to make specification changes as required.

### 3.2 Tools

12mm, 8mm and 4mm flat blade screwdriver and pozi head screwdriver.

Suitable spanners for installing cable glands.

Pliers, knife, wire strippers/cutters.

### 3.3 Electrical Supplies

Luminaires fitted with electronic control gear are suitable for a rated supply of 220-240V AC 50-60Hz. The safety limits are +10% of this. The supply would normally be expected to lie within +/-6% of rated. The LED supply is regulated therefore the light output over the range is substantially unchanged.

Electronic gear has integrated power factor correction to >0.90.

**Warning:** Electronic control gear is assessed and/or tested for EMC requirements. This is based on the disposition of entry cables and, where appropriate, through wiring arrangements as supplied or specified. Users must take care not to introduce wiring into parts of the apparatus materially different to that which could be reasonably inferred from the disposition of fixed supply terminals and specified through wiring.

Luminaires with dimming facility can be sensitive to pulses within the supply system, if UPS units are connected to the same Distribution boards as the lighting circuits, it is advisable to use isolating transformers within the circuit.

### 3.4 Light Emitting Diode (LED)

LED's are supplied in either 3000 or 4000 Lumen options with the colour temperature of 4000K or 3000K

### 3.5 Mounting

Luminaires should be installed where access for maintenance is practical and in accordance with lighting design information. Refer to the note in 3.1 concerning electrostatic charge.

Where the luminaire is to be part of the ceiling construction, for aesthetic reasons, care is to be taken to ensure that the spacing and height specified by ceiling type is met. Mounting is via diameter 8mm holes for drop rods or directly onto the T grid of the ceiling.

**Modular Types:** Prior to mounting remove front cover by undoing quarter turn fasteners then undo clips strapping cover to body. Place front cover in a safe and clean place so as not to accumulate dust.

*Exposed T ceilings:* Remove adjacent ceiling tiles from the sides of the luminaire, lift the luminaire into the ceiling aperture and whilst supporting, bend the body cut-outs so that the arms are perpendicular to body. Lower the luminaire until the groove in the arms fits onto Tee brackets. Care should be taken when bending the cut-outs so as not to weaken the joints.

*Spring T ceilings:* Remove the adjacent tiles from the sides where the ceiling suspension mates. Lift the luminaire into the ceiling aperture and whilst supporting, fit two of the cams on diagonally opposite corners and screw in place. Rest the luminaire onto spring Tee brackets. The luminaire is now temporarily supported and remaining cams may be now fitted.

**Non-modular types:** Prior to mounting remove front cover by undoing quarter turn fasteners then undo clips strapping cover to body. Place front cover into a safe and clean place so as not to accumulate dust.

Lift the luminaire into the ceiling aperture, position luminaire until the front flange meets the ceiling face. Whilst supporting, fit two brackets diagonally opposite corners through the slots. Adjust and tighten brackets to secure luminaire against ceiling face. Rest the luminaire onto support structure. The luminaire is now temporarily supported and remaining brackets may be now fitted.

Brackets can be mounted with hook-up or hook-down to suit type of mounting directly on to ceiling or on to support structure

### 3.6 Cabling and Cable Glands

#### 3.6.1 Cables

The temperature conditions of the supply cable entry point are such that 70°C (ordinary PVC) cable can be used in all luminaires. 300/500 volts cable ratings are adequate and no special internal construction is necessary. The selection of the cable size will be suitable for the fuse rating, which applies to the circuit on the supply side of the control gear. The standard maximum looping size is 4mm<sup>2</sup>.

#### 3.6.2 Cable Glands

Cable glands for entry into enclosures, when fitted with any gland to body sealing method and the supply cable, must reliably maintain the IP rating of the enclosure. Four Ø21mm entry holes, two in the rear and two in the side, are provided suitable for 20mm entries. Three of the entry holes have sealed plugs already installed and are suitable for permanent use. The other entry hole has a travelling plug. If cable glands are to be used as earth then care must be taken to ensure suitable earth connections is made as body material is pre-coated steel. Kits are available and an internal earth point is fitted as standard.

### 3.7 Electrical Connections

Luminaires are supplied suitable for looping. The through current rating is 16A. 4mm<sup>2</sup> terminals are standard. Mains terminal blocks are marked Lc Ls N Earth. The emergency units can be connected as switched, un-switched or non-maintained units. The switching facility is to allow the luminaire to be switched off whilst still charging the battery. Where switching is required, the un-switched line (Lc) is connected to the continuous mains supply and a switched supply is connected to the Ls. A link is fitted during assembly between Lc and switched line (Ls); this is removed for the switch-able mode. If the link is removed and Ls not supplied, the unit will only operate on emergency.

#### 3.8.1 Installation

Following the mounting of the apparatus (refer to 3.5) ensure luminaire is isolated from the system before any work is done. The terminal block is fitted on to the body and can now be accessed. Install the conductors in the appropriate terminals. Take care not to cut the conductor insulation excessively, 1mm of bare conductor outside the terminal throat is a maximum. Unused terminal screws should be tightened.

After supply cable is connected the unit can be tested with a high impedance 500 V dc insulation tester to IEC 364 or BS 7671 **provided all line and neutral connections are solidly connected together** for the test.

When the unit is ready for operation the mains and the battery connections must be made, the unit is supplied with the battery disconnected. After commissioning, the unit can be shut down for a long period without loss of function. Before re-fitting the front cover, the cores/cable should be neatly tucked away and a final check made on correct connections.

#### 3.8.2 Commissioning

Energise the mains and check that LED strips illuminate when the supply is energised.

Emergency luminaires are supplied with the Battery plug/Socket disconnected. Just prior to switching power on, connect battery plug and socket.

Emergency luminaires will require battery packs to be cycled to obtain the full duration/capacity of the Ni-Cd battery cells. It is recommended that the unit is charged for a minimum period of 24 hours, then permitted to discharge via emergency operation (power OFF), and then charged again for a minimum period of 24 hours.

If checking battery duration at this time it may be necessary to repeat the cycle to obtain the full 3 hour duration.

### 3.8.3 Post Commissioning Storage

It is assumed that during commissioning the battery plug and socket are connected.

If the power is to be removed after commissioning for a period of time, our recommendations, along with guidance from the battery manufacturer, are:

- Up to 6 months – No action required. Mains power can be reapplied during this time and the battery will accept a charge.
- 6 to 12 months – Disconnect battery plug and socket to maintain charge in the battery. Before re-connection of mains power re-connect the battery plug and socket. Mains power can be reapplied and the battery will accept a charge.
- Longer than 12 months – Disconnect battery plug and socket. Approximately every 6 months carry out a charging/discharging cycle, 24 hours charging followed by 3 hour discharge and another 24 hour charge, then isolate power and disconnect battery plug & socket. This is to avoid deep discharge of cells, which is caused by a trickle discharge or by long term storage. This could lead to the cells not accepting a charge from the inverter or not achieving full expected duration.

### 3.9 Replacing LED's

Before opening the front cover ensure that the luminaire is isolated from the mains supply. Access for replacing LED's is via the front cover. Remove front cover by undoing quarter turn fasteners. Care should be taken opening the cover. The cover is suspended by straps on one side.

Make sure that the correct ESD protection is taken during LED replacement to avoid electric discharge to the PCB.

### 4.0 Inspection and Maintenance

We recommend a visual inspection of LED's and control gear for discolouration, when replacing LED's or during a scheduled maintenance check. On battery models, we recommend that the battery duration is checked periodically.

#### 4.1 Replacement of Electronic Ballast and Inverter Unit *(Where Fitted)*

The electronic LED driver and inverter contain no replaceable parts. Should it be found necessary to replace this part, the following procedure should be adopted:

1. Ensure that the luminaire is isolated from both mains and battery supply otherwise a risk of shock may occur. Disconnect the plug and socket battery connection then the leads on the ballast at the terminal block.
2. Undo the driver securing screws and washers and withdraw the driver from the body.
3. Replace in reverse order.
4. Replacement of the inverter is identical.

#### 4.2 Battery Check and Replacement

The battery is contained in a tube which is sealed. The battery is detached at the plug and socket. Remove the two screws and washers to release the battery. Re-assembly is in reverse order.

**Important:** *Isolate the mains supply and disconnect the battery terminal before carrying out any work.*

#### 4.3 Routine Examination

The luminaire must be de-energised before opening. Individual organisations will have their own procedures. What follows are guidelines based on our experience:

- 1 Ensure LED's are lit when energised by mains supply and emergency LED's on battery pack.
- 2 Visually check cover front for damage, this should only be cleaned using a damp cloth, to avoid static, and only use recommended detergents for polycarbonates.
- 3 If the diffuser is discoloured or damaged, a new front cover assembly must be fitted.
- 4 When de-energised and left to cool, there should be no significant sign of internal moisture. If there are any signs of water ingress, the luminaire should be opened up, dried and any likely ingress points eliminated by replacement of cover assembly.
- 4 Check cable gland for tightness and nip up if required.
- 5 Check any external and internal earths.

- 6 Check all terminations are firmly screwed down, tighten if necessary.
- 7 Check battery securing screws are tight, when fitted.
- 8 Check cover quarter turn fasteners are flush with cover front and washers for wear.
- 9 If it has been suspected that the luminaire has suffered mechanical damage, a stringent workshop check on all components should be made. All components can be removed from the luminaire for inspection.

## 5.0 Disposal of Material

The unit is made from combustible materials. The control gear contains plastic parts. All electrical components and the diffuser parts may give off noxious fumes if incinerated. Take care to render these fumes harmless or avoid inhalation. Any local regulations concerning disposal must be complied with. Any disposal must satisfy the requirements of the WEEE directive [2012/19/EU] and therefore must not be treated as commercial waste. The unit is mainly made from incombustible materials. The control gear contains plastic, resin and electronic components. All electrical components may give off noxious fumes if incinerated.

### 5.1 LED's

LED's in modest quantities are not "special waste". They should be broken in a container to avoid possible injury from fragmentation. Avoid inhaling dust. This applies to the UK; there may be other regulations on disposal operating in other countries.

**Important:** *Do not incinerate LED's.*

### 5.2 Battery Disposal

Nickel cadmium batteries are defined as 'controlled waste' under the hazardous waste regulations and the disposer needs to observe a 'duty of care'.

Batteries can be returned to the manufacturers for re-cycling. They must be stored and transported safely and any necessary pollution control forms completed prior to transportation. Take care to fully discharge batteries before transporting or otherwise ensure that there can be no release of stored energy in transit. For further details refer to our Technical Department.

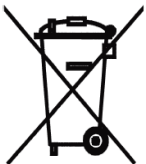

To comply with the Waste Electrical and Electronic Equipment directive 2012/19/EU the apparatus cannot be classified as commercial waste and as such must be disposed of or recycled in such a manner as to reduce the environmental impact.

## 6.0 Emergency Self Test or Battery Monitoring Versions

This version is capable of testing the performance of the emergency Luminaire in accordance with IEC 62034.

### Commissioning

After installation of the Luminaire and initial connection of the mains supply will initiate commissioning where the battery will remain on charge for an uninterrupted 24 hours. At this time the module will conduct a commissioning test for the full duration.

The 24 hours recharge occurs also if a new battery is connected or the module exits the rest mode condition. The following automatic commissioning duration test is only performed when a battery is replaced and fully charged (after 24 hrs) and the interval time is not set to zero, otherwise the system is expected to perform the testing.

If the mains supply is to be interrupted for more than 7 days, then the battery **MUST** be disconnected.

### Functional test

The time of day and frequency of the 5 seconds function test can be set by the DALI controller. The default setting is a 5 seconds test on a weekly basis.

### Duration test

The time of day and frequency of the duration test can be set by the DALI controller. The default setting is a duration test conducted every 52 weeks.



**LED Indicator** - A bi-colour LED indicates the status of the module as follows:

LED Indication	Status	Comment
Permanent green	System OK	AC mode
Fast flashing green (0,1 sec on – 0,1 sec off)	Function test underway	
Slow flashing green (1 sec on – 1 sec off)	Duration test underway	
Red LED on	Load failure	Open circuit / Short circuit / LED failure
Slow flashing red (1 sec on – 1 sec off)	Battery failure	Battery failed the duration test or function test / Battery is defect or deep discharged/ Incorrect battery voltage
Fast flashing red (0,1 sec on – 0,1 sec off)	Charging failure	Incorrect charging current
Green and red off	DC mode	Battery operation (emergency mode)

**Chalmit Lighting is a leading supplier of Hazardous Area lighting products**

	<p><b>CHALMIT LIGHTING</b> PO Box 5575 Glasgow, G52 9AP Scotland</p>	
<p>Telephone: +44 (0) 141 882 5555 Fax: +44 (0) 141 883 3704 Email: info@chalmit.com Web: www.chalmit.com</p>	<p>Registered No: 669157 Registered Office: Cannon Place 78 Cannon Street London EC4N 6AF UK</p>	

**For technical support, please contact: techsupport@chalmit.com**

Note: Chalmit Lighting reserves the right to amend characteristics of our products and all data is for guidance only.



	<b>EU-Declaration of conformity</b>		
	<b>UE-Déclaration de conformité</b>		
	<b>EU-Konformitätserklärung</b>		
Manufacturer	Chalmit	Address	388 Hillington Road, Glasgow. G52 4BL Scotland UK
Product	Curie Recessed Fluorescent Industrial		
Catalogue	CURI/***/**/* Example: CURI/03L/LE/EM		
Area Classification	Non- Hazardous		
Ingress Protection	IP20 & IP44 (Front Cover Only) to EN 60529		
Ambient	-20°C to 45°C (Non Emergency), -20°C to 40°C (Emergency)		
Terms of the directive:		Standard & Date Certified to	Standards Date Declared to
2014/30/EU		Electromagnetic compatibility	EN 55015 : 2013
2014/30/UE		Compatibilité électromagnétique	EN 61547 : 2009
2014/30/EU		Elektromagnetische Verträglichkeit	EN 61000-3-2 : 2014
2014/35/EU		Low voltage equipment	EN 60598-1 : 2015
2014/35/UE		Équipements électriques à bas voltage	EN 60598-2-5 : 2015
2014/35/EU		Niederspannungsgeräte / -systeme	EN 60598-2-22 : 2014
			EN 60529 : 1992
2012/19/EU		Waste of electrical and electronic equipment	
2012/19/UE		Déchets d'équipements électriques et électroniques	
2012/19/EU		Entsorgung der elektrischen und elektronischen Geräte / Systeme	
2011/65/EU		RoHS II Directive	

On behalf of the Chalmit, I declare that, on the date the equipment accompanied by this declaration is placed on the market, the equipment conforms to all technical and regulatory requirements of the above listed directives.

En tant que représentant du fabricant Chalmit, je déclare qu'à la date où les équipements accompagnant cette déclaration sont mis sur le marché, ceux-ci sont conformes à toutes les dispositions réglementaires et techniques des directives énumérées ci-dessus.

Hiermit bestätige ich, im Namen von Chalmit, dass am Tag der Lieferung des Produkts/der Produkte zusammen mit dieser Erklärung das Gerät/die Geräte alle technischen und regulativen Anforderungen der oben aufgeführten Direktiven erfüllt.

Name and Date Mark Poutney 14/11/2016  
 Nom et Date  
 Name und Datum

Technical Manager  
 Directeur technique  
 Technischer Leiter

Quality Management System Accreditation:  
 Système de Management Qualité Accréditation:  
 Qualitätsmanagementsystem Akkreditierung:  
 Environmental Management System.  
 Système de gestion de l'environnement.  
 Umwelt kontroll system.  
**Certificate No./Certificat N°/Zertifikat Nr.**

**ISO 9001**

**ISO 14001**  
 by/par/durch  
**Lloyd's Register**  
**LRQ 4005876**