



# INSTALLATION, OPERATION AND MAINTENANCE INSTRUCTIONS

## Starline II LED- Street Lantern Industrial

**Important:** Please read these instructions carefully before installing or maintaining this equipment. Good electrical practices should be followed at all times and this data should be used as a guide only.

Starline II LED complete with Spigot Entry Mount  
Suitable for Pole Diameters 48 to 60mm O/D  
Catalogue Standard Option – No Abbreviation

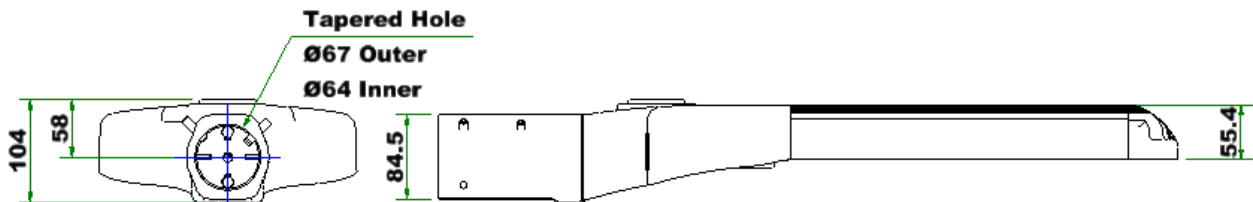
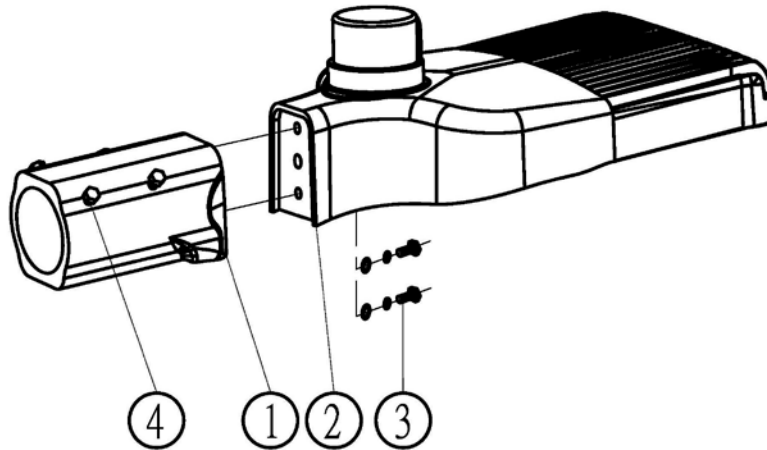

Fitting Type	Dim L
05L	393mm
09L	393mm
13L	444mm
17L	495mm
24L	601mm

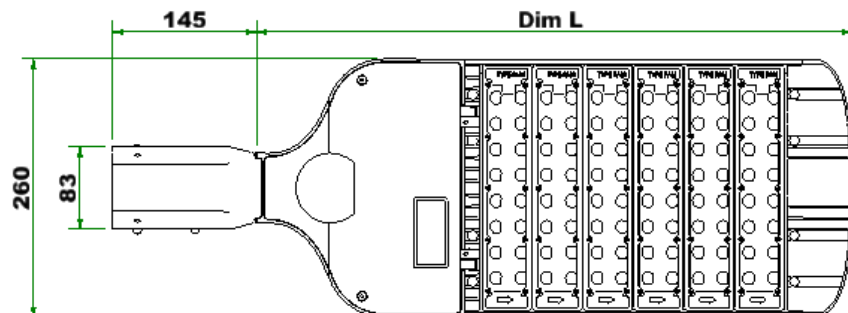



Starline II LED complete with Slip Fitter Mount  
Suitable for Pole Diameters 40 to 55mm O/D  
Catalogue Abbreviation Option - /SFM

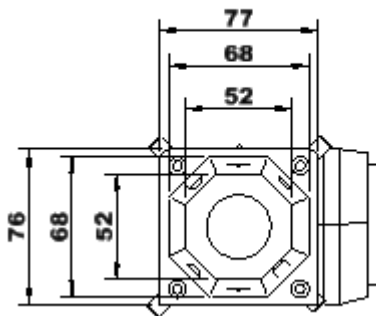
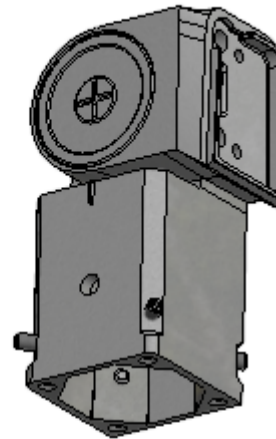
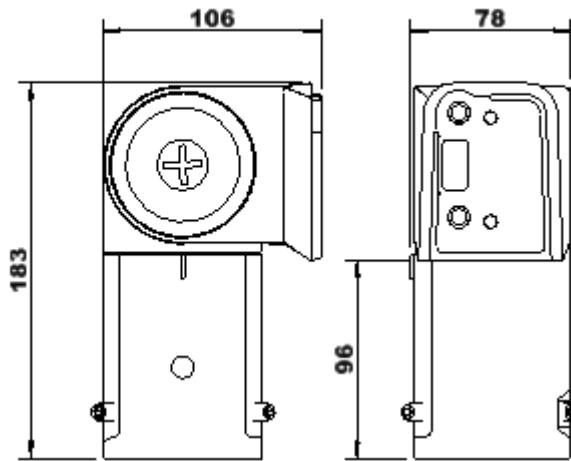
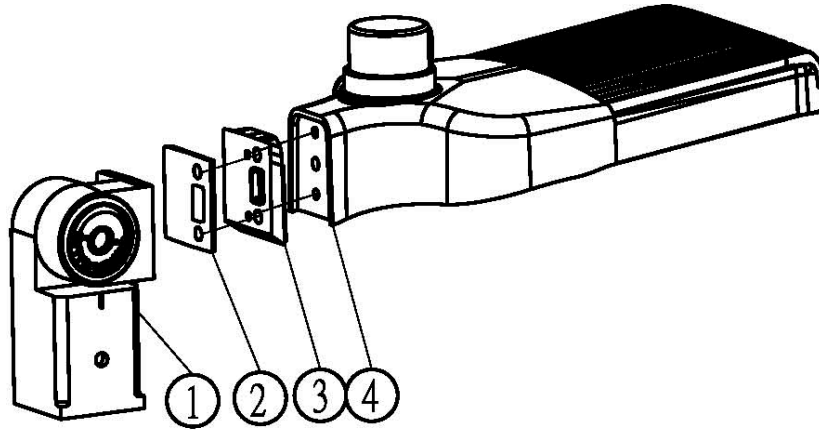

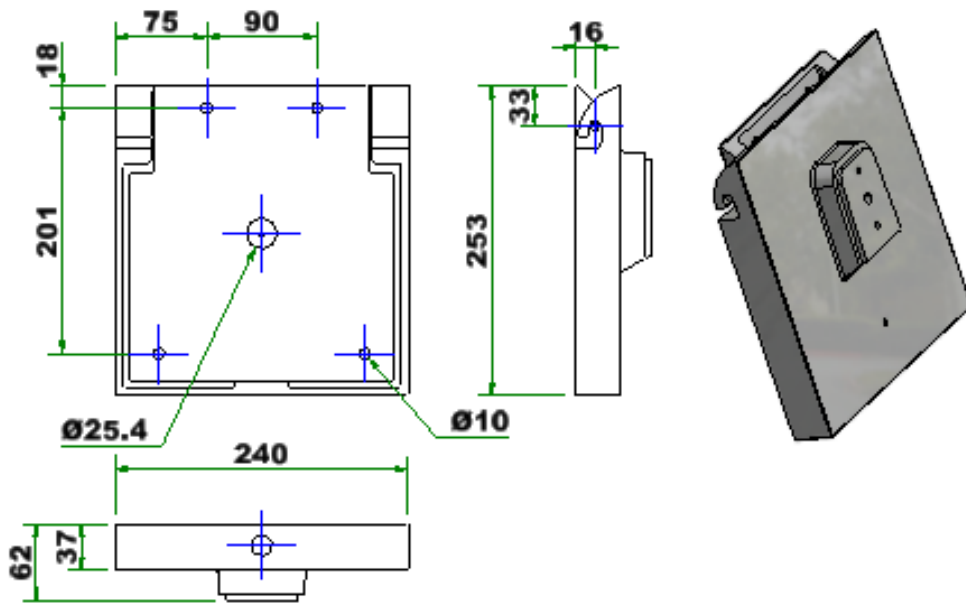
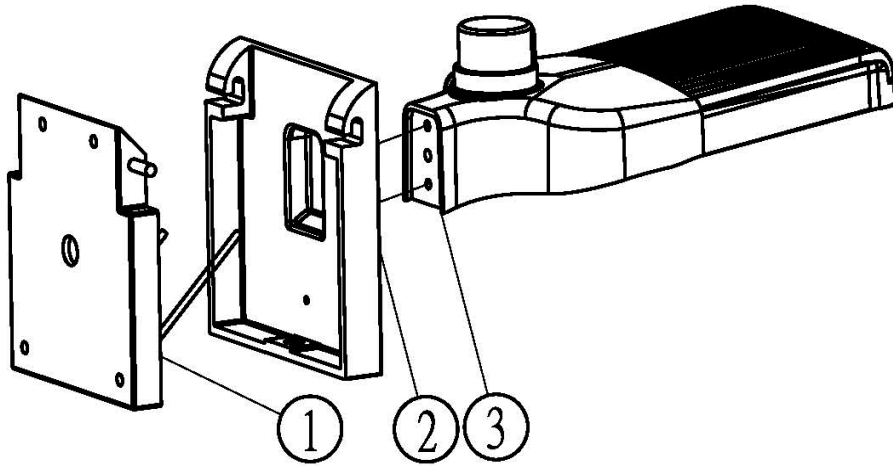

**Spigot Entry for Post Top Mounting  
suitable for Poles with Outside  
Diameters 40 - 55mm**

Starline II LED complete with Wall Mount  
Catalogue Abbreviation Option - /WM





<b>0.0 Specification</b>	
Standards	EN 60598-1
Area Classification	Industrial, (Non- Hazardous)
Ingress Protection	IP65 to EN 60529
  	<p>The CE marking of this product applies to "The Electrical Equipment (Safety) Regulations 2006", "The Electromagnetic Compatibility Regulations 2004", the "Waste Electrical and Electronic Equipment Regulations 2006". [This legislation is the equivalent in UK law of EU directives 2014/35/EU, 2014/30/EU, 2012/19/EU respectively].</p> <p>The UKCA marking of this product applies to "The Electrical Equipment (Safety) Regulations 2016", "The Electromagnetic Compatibility Regulations 2016", the "Waste Electrical and Electronic Equipment Regulations 2012</p> <p>M Poutney Technical Manager</p>

**MEGOHM TEST - DUE TO THE SURGE PROTECTION PROVIDED IN THE LUMINAIRE TO PROTECT THE INTERNAL ELECTRONICS AND LEDs, A CIRCUIT WITH THE LED FIXTURE MAY GIVE A FALSE MEGOHMMETER (MEGGAR) READING. IF A MEGOHMMETER TEST IS REQUIRED, THE LED FIXTURE SHOULD BE REMOVED FROM THE CIRCUIT.**

### 1.0 Introduction

The Starlin ell range of Chalmit LED street lighting equipment is suitable for group A and B applications to BS.5489-1 & EN 13201-2:2003.

**Table 1 MODEL VARIATIONS**

CHALMIT MODEL NUMBER	ANBIENT	WATTS MAX	Hz	VOLTS	AMPS	LUMENS
SL2I/05L/LE	+ 55°C	40	50/60	120-240	0.3 - 0.15	4835
SL2I/09L/LE	+ 55°C	75	50/60	120-240	0.6 - 0.3	8923
SL2I/13L/LE	+ 55°C	120	50/60	120-240	1.0 – 0.5	13226
SL2I/17L/LE	+ 55°C	150	50/60	120-240	1.2 – 0.6	17355
SL2I/24L/LE	+ 55°C	200	50/60	120-240	1.7 – 0.8	24318

### 1.1 General

Installation should be carried out in accordance with BS.5489 and any local code of practice and wiring regulations in the UK the requirements of the "Health and Safety at Work Act" must be met. LED's must be disposed of in a safe manner. Care must be taken to properly secure the luminaire and provide suitable supporting equipment when installation and maintenance work is being carried out. The lanterns are Class 1 and must be effectively earthed.

### 1.2 Recommendations

**Applications:** Major roads, motorways, car parks & industrial areas.  
**Insulation Class:** 1  
**Input:** 120V - 240V (+/- 6%) 50-60Hz  
**Mounting Height:** Specified by Lighting Design Scheme

### 2.0 Electrical Supplies

The supply voltage and frequency range is 110 to 240V 50/60Hz, with supply tolerance +/- 6%.

### 2.1 Mounting

This luminaire can be mounted either Spigot Entry (side entry), Slip fitter (post top) and Wall Mounting, option to be specified when ordering. For suitable pole diameters see list below and see above diagrams with options and abbreviations.



### 2.1.1 Spigot Mounting

Lift the spigot entry (item 1) towards the luminaire chamber with the flying leads (item 2) and feed through the centre hole of Item 1.

Add a bead of silicone sealant around the mating face perimeter of item 1 (to assist Ingress protection).

Push the two mating faces together and secure, using the two screws (Item 3) tighten to 14Nm.

Fit the assembly onto the 48-60mm diameter pole, ensure pole is fully inserted into the spigot entry and then align front face parallel to the ground. Tighten the 4 screws (Item 4) to 14Nm.

### 2.1.2 Slip Fitter Mounting

Lift the slip fitter entry (item 1) towards the luminaire chamber with the flying leads (item 2) and feed through the centre hole of Item 1.

Add a bead of silicone sealant around the mating face perimeter of item 1 (to assist Ingress protection).

Push the two mating faces together and secure, using the two screws (Item 3) tighten to 14Nm.

Fit the assembly onto the 40-55mm diameter pole, ensure pole is fully inserted into the slip fitter entry and then align front face parallel to the ground. Tighten the 4 screws (Item 4) to 14Nm.

### 2.1.3 Wall Mounting

Lift the Wall Mounting (item 2) towards the luminaire chamber with the flying leads (item 3) and feed through the centre hole of Item 2.

Add a bead of silicone sealant around the mating face perimeter of item 3 (to assist Ingress protection).

Push the two mating faces together and secure, using the two screws tighten to 14Nm.

Secure item 1 to the wall with appropriate fasteners and lift the assembly above, feed the wires through the centre hole and hook the brackets together.

## 2.2 Cables

The flying leads should be terminated for connection to the mains supply cable, care should be taken to ensure that the correct leads are connected for supply voltage and type. The fitting can be connected for 120-240V, for example if your supply voltage is 120V, connect the "HOT" supply wire to 120V ballast tap and the "COMMON" supply wire to the transformer "COMMON" wire, made sure all of the unused leads are properly capped.

## 3.0 LED Array Module & Reflector

Do not touch LED module or reflector

## 4.0 Inspection and Maintenance

Individual organisations will have their own procedures for inspection and maintenance. What follows are guidelines based on Chalmit's experience.

Maintenance work and fault finding must be performed by competent personnel under an appropriate permit to work and with the apparatus isolated.

- 1) Ensure that the LED's illuminate when energised, subject to PEC control.
- 2) Examine for water ingress. If there is water ingress this should be dried out. The luminaire should be examined to determine the method of ingress and then rectified.
- 3) Check the incoming cable terminal connections and the security of the cable gland/clamp.
- 4) Clean the bowl.
- 5) In the event of a failure, please contact the manufacturer for advice & guidance.

## 5.0 Disposal of Material

The lantern is chiefly made from inert incombustible materials

All the electrical components may give off noxious fumes if incinerated. Care must be taken to render these fumes harmless or avoid inhalation.

Any local regulations concerning disposal must be complied with. Any disposal must satisfy the requirements of the WEEE directive [2012/19/EU and Regulations 2012] and therefore must not be treated as commercial waste. The unit is mainly made from incombustible materials. The control gear contains plastic, resin and electronic.



To comply with the Waste Electrical and Electronic Equipment directive 2012/19/EU and Regulations 2012 the apparatus cannot be classified as commercial waste and as such must be disposed of or recycled in such a manner as to reduce the environmental impact.

## 6.0 Orientation

The Luminaire is not available to face upwards for LED light, is only available for face downward.

**IMPORTANT**-to weather- proof your outdoor installation, be sure to seal all housing (Mounting, Conduit, Plugs, Etc.) with silicone sealant.

## TROUBLE SHOOTER - CHECK LIST

**IF LIGHT DOES NO WORK:** Check Your Power Source.  
 Check Electrical Connections.  
 Check to Insure Proper Seating Of Lamp.  
 Check If LED Burned Out.

Chalmit Lighting is a leading supplier of Hazardous Area lighting products

		<b>CHALMIT LIGHTING</b> PO Box 5575 Glasgow, G52 9AP Scotland			
Telephone:	+44 (0) 141 882 5555	Registered No:	669157	Registered Office:	Cannon Place
Fax:	+44 (0) 141 883 3704				78 Cannon Street
Email:	info@chalmit.com				London EC4N 6AF UK
Web:	www.chalmit.com				

For technical support, please contact: [techsupport@chalmit.com](mailto:techsupport@chalmit.com)

Note: Chalmit Lighting reserves the right to amend characteristics of our products and all data is for guidance only.



	<b>EU/UK-Declaration of conformity</b>		
	<b>UE-Déclaration de conformité</b>		
	<b>EU-Konformitätserklärung</b>		
Manufacturer	Chalmit	Address	388 Hillington Road, Glasgow. G52 4BL Scotland UK
Product	Starline II Industrial Street Lantern		
Catalogue	SL2I/**/**/	Example: SL2I/05L/LE	
Area Classification	Industrial, (Non- Hazardous)		
Ingress Protection	IP65		
Ambient	Tamb -40°C to +55°C		
Terms of the directive:		Standard & Date Certified to	Standards Date Declared to
2014/30/EU Regulations 2016	Electromagnetic compatibility	EN 55015 : 2019	
2014/30/UE	Compatibilité électromagnétique	EN 61547 : 2009	
2014/30/EU	Elektromagnetische Verträglichkeit	EN 61000-3-2:2019 EN 61000-3-3:2013	
2014/35/EU Regulations 2016	Low voltage equipment	EN 60598-1 : 2015	
2014/35/UE	Équipements électriques à bas voltage	EN 60598-2-3 : 2003+A1:2011 EN 62471 : 2008	
2014/35/EU	Niederspannungsgeräte / -systeme	EN 60529 : 1992+A2:2013	
2012/19/EU Regulations 2012	Waste of electrical and electronic equipment		
2012/19/UE	Déchets d'équipements électriques et électroniques		
2012/19/EU	Entsorgung der elektrischen und elektronischen Geräte / Systeme		
2011/65/EU Regulations 2012	RoHS II Directive		

On behalf of the Chalmit, I declare that, on the date the equipment accompanied by this declaration is placed on the market, the equipment conforms to all technical and regulatory requirements of the above listed directives.

En tant que représentant du fabricant Chalmit, je déclare qu'à la date où les équipements accompagnant cette déclaration sont mis sur le marché, ceux-ci sont conformes à toutes les dispositions réglementaires et techniques des directives énumérées ci-dessus.

Hiermit bestätige ich, im Namen von Chalmit, dass am Tag der Lieferung des Produkts/der Produkte zusammen mit dieser Erklärung das Gerät/die Geräte alle technischen und regulativen Anforderungen der oben aufgeführten Direktiven erfüllt.

Name and Date  
Nom et Date  
Name und Datum

Mark Poutney 11/11/2021

Technical Manager  
Directeur technique  
Technischer Leiter

Quality Management System Accreditation:  
Système de Management Qualité Accréditation:  
Qualitätsmanagementsystem Akkreditierung:  
Environmental Management System.  
Système de gestion de l'environnement.  
Umwelt kontroll system.  
**Certificate No./Certificat N°/Zertifikat Nr.**

**ISO 9001**

**ISO 14001**  
by/par/durch  
**Lloyd's Register**  
**LRQ 4005876**