

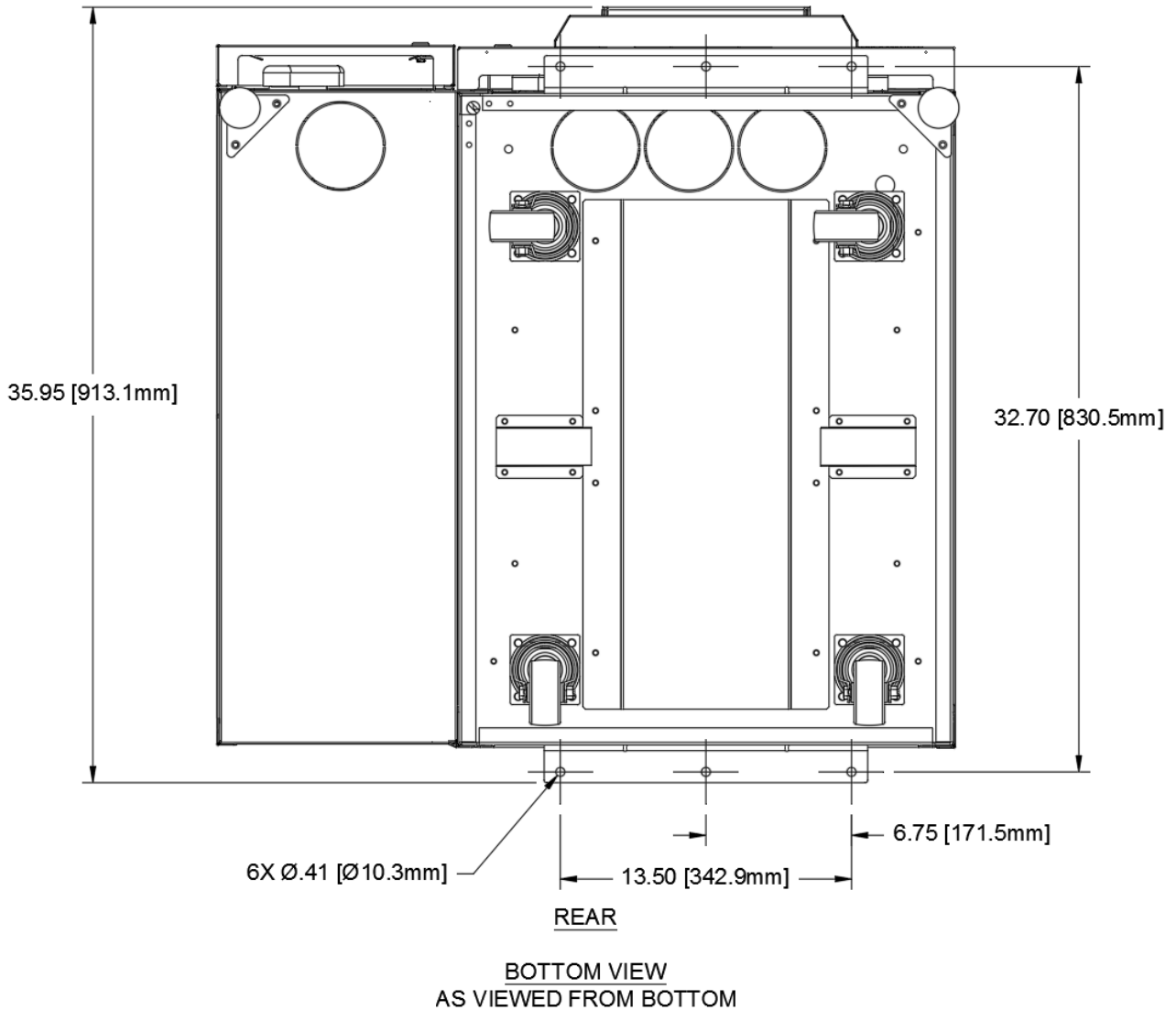

## TRF 50-60 kVA UPS Seismic Mounting Instructions

Locate the final position of the UPS. Using the dimensions in Figure 1, locate the mounting anchor locations and properly prepare anchors.



**Figure 1 - Anchor locations**

## TRF 50-60 kVA UPS Seismic Mounting Instructions

There are 2 brackets per kit that mount to the front and rear of each cabinet. Remove any shipping brackets and associated hardware that came with unit. Each bracket mounts with the following hardware (see Figure 2):

- (4) M5 X 0.8 X 20 Bolt
- (4) #10 Belleville washer

Mounting Bolts from bracket to UPS recommended torque: 3.9 ft-lbs (5 N-m)

The floor anchors are determine by site conditions and is determine by Engineer of Record for the site.

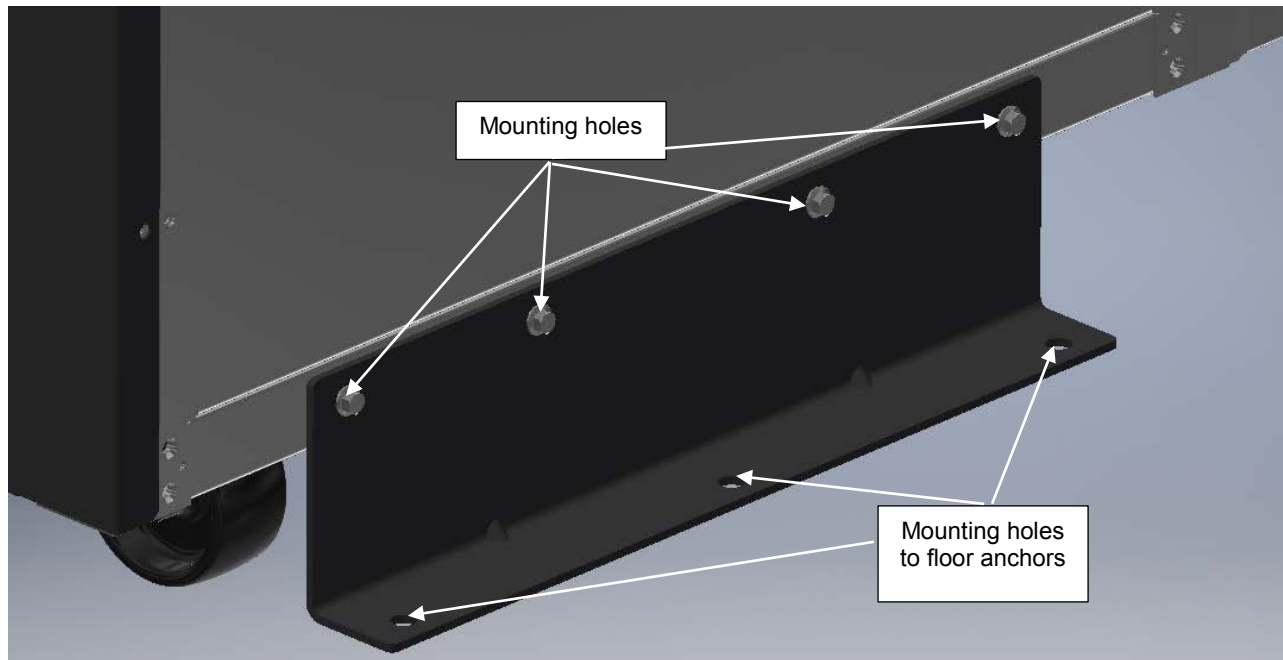

Figure 2 – Mounting holes from bracket to UPS



Dual-Lite • [www.dual-lite.com](http://www.dual-lite.com)

A Hubbell Lighting, Inc. brand with representatives' offices in principal cities throughout North America.

Copyright © Hubbell Lighting, Inc., All Rights Reserved • Specifications subject to change without notice. • Printed in U.S.A. 003-2619 02/18