



Emergency LED Exit Sign Listed for Wet locations
AC, Emergency & Spectron Emergency rated N4X/IP66
Installation, Operation, and Service Instructions

"AC ON" LED is illuminated when AC power is present.

NOTE: All models are supplied with an AC Lockout Circuit, which prevents the "EXIT" legend from illuminating when the battery is connected and no AC power is present.

NOTE: All models are supplied with a Low Voltage Disconnect circuit, which prevents damage to the battery from deep discharge during prolonged emergency operation.

NOTE: Batteries are often shipped in a discharged state - this is normal. The battery will require charging. Allow several hours of charge before testing the unit.

Models With SPECTRON® Self-Testing/Self-Diagnostic Circuitry

Models equipped with the SPECTRON self-testing/self-diagnostic electronics system provide:

- Visual indication of AC power status
- Visual indication of self-diagnostic test cycle
- Visual indication of any unit malfunctions including:
 - Battery disconnect
 - Battery fault
 - Transfer fault
 - Charger fault
 - Emergency Lamp fault

Spectron equipped units also include:

Brownout protection: unit will automatically transfer to emergency operation upon detection of low AC power (approximately 80% of normal line).

Time Delay Retransfer: upon return of normal AC power, unit will remain in the emergency mode for an additional 15 minutes to allow AC power to stabilize.

LED Status Indicator

A bicolor LED (red/green) is provided on the control panel of all models equipped with Spectron option.

Green Operating Status Indicator

The green Operating Status Indicator serves as both an AC power and self-test indicator. During normal operation, the green Operating Status Indicator will be illuminated, indicating the presence of AC power. During all automatic or manual self-test cycles, the green Operating Status Indicator will blink at a 1 Hz rate.

Red Service Alert Indicator

Under normal operating conditions, the red Service Alert Indicator will remain off. In the event the Spectron controller detects a malfunction, the red Service Alert Indicator will blink at a 1 Hz rate, based on the following table:

Red Status Indicator Code	Description
One blink ON/pause	Battery not connected
Two blinks ON/pause	Battery fault
Three blinks ON/pause	Charger fault
Four blinks ON/pause	Transfer circuit fault
Five blinks ON/pause	Emergency Lamp fault

Automatic Tests

The unit will automatically initiate a self-test/self-diagnostic cycle based on the following table:

Testing Period	Duration of Test
Once a month	1 minute
Once every 6 months	Alternating: 30 minutes or 60 minutes

Manual Tests

Using the unit test switch, users can initiate different duration test cycles based on the following table:

Initiating Action	Test Cycle
Press test switch once	1 minute
Press test switch twice	90 minutes



93075474

MAINTENANCE

TROUBLE SHOOTING

- "EXIT" legend does not illuminate
 - check wiring connections
- Emergency Circuit does not work
 - Batteries are shipped uncharged and disconnected. Connect power pack leads charge before testing.
 - Make sure charger board is properly seated.
 - Check wiring connections.

MAINTENANCE

Signs should be tested and maintained in accordance with National Electrical Code and NFPA 101 Life Safety Code requirements. It is recommended that emergency exit signs be tested for 30 seconds once a month and for 90 minutes once a year.

RECYCLING INFORMATION

All thermoplastic parts are recyclable.
All cartons contain recycled materials.
Please recycle responsibly.



NOTICE:

Emergency model exit signs contain rechargeable Nickel Metal Hydride batteries which must be recycled or disposed of properly.

IMPORTANT SAFEGUARDS

When using electrical equipment, basis safety precautions should always be followed including the following.

READ AND FOLLOW ALL SAFETY INSTRUCTION

1. Do not let power supply cords touch hot surfaces.
2. Do not mount near gas or electric heaters.
3. Equipment should be mounted in locations and at height where it will not readily be subjected to tampering by unauthorized personnel.
4. The use of accessory equipment not authorized by the manufacturer may cause an unsafe condition.
5. Do not use this equipment for other than its intended purpose.
6. Servicing of this equipment should be performed by qualified service personnel.
7. Test cycling: the Life Safety Code (NFPA 101) requires testing of emergency exit signs once a month for a minimum of 30 seconds and once a year for a minimum of 90 minutes.

INSTALLER

- SEE UNIT LABEL FOR ADDITIONAL MODEL SPECIFICATIONS
- SAVE THESE INSTRUCTIONS FOR USE BY OWNER/OCCUPANT

WARNING: - This product contains chemicals known to the State of California to cause cancer, birth defects and/or other reproductive harm. Thoroughly wash hands after installing, handling, cleaning or otherwise touching this product.

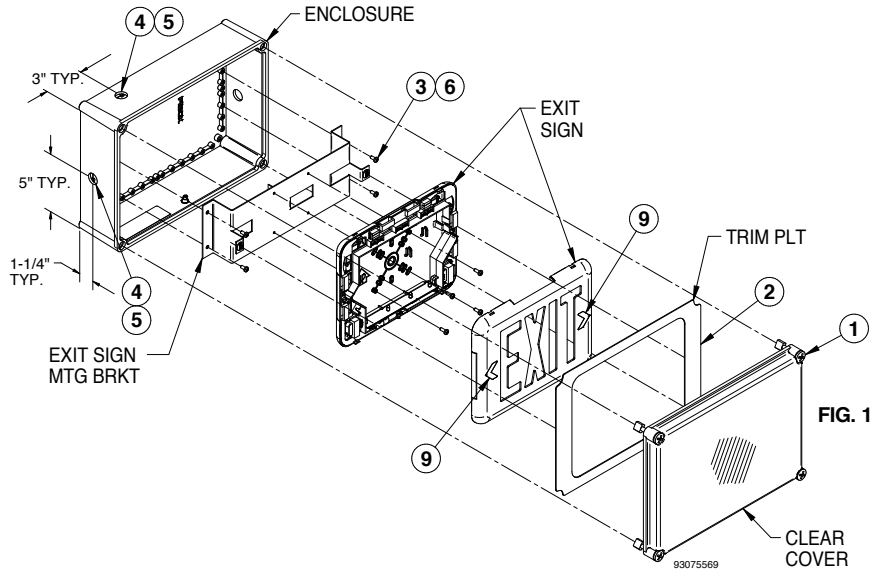

FIG. 1

STEPS:

1. Loosen the four slotted captive cover screws and remove the clear cover (qty 4).
2. The white trim plate surrounding the exit sign face is held in place by "hook and loop" velcro, located on the underside of the trim plate. Remove the trim plate by carefully lifting straight up to disengage the velcro.
3. Remove the exit sign and mounting bracket by removing 4 bracket mtg plate screws (qty 4) before proceeding to step 4.
4. If needed, drill the appropriate size hole to dim's shown for conduit entry.
5. Only use UL Listed water tight conduit fittings that meet the requirements of the UL 514B Standard for Conduit Tubing and Cable. Route building utility conductors through conduit and into enclosure.
6. Reinstall mounting bracket and exit sign. Remove exit sign front face from housing before proceeding to step 7.
7. Make all connections to building utility AC conductors using color coded leads provided. (See Fig. 2)
8. For em models, connect the battery as shown. (see Fig. 3).
9. Snap-in appropriate chevron arrows in exit stencil face , if required.
10. Energize the AC power to the exit sign.

NOTE: For emergency models, allow the battery to fully charger before testing.

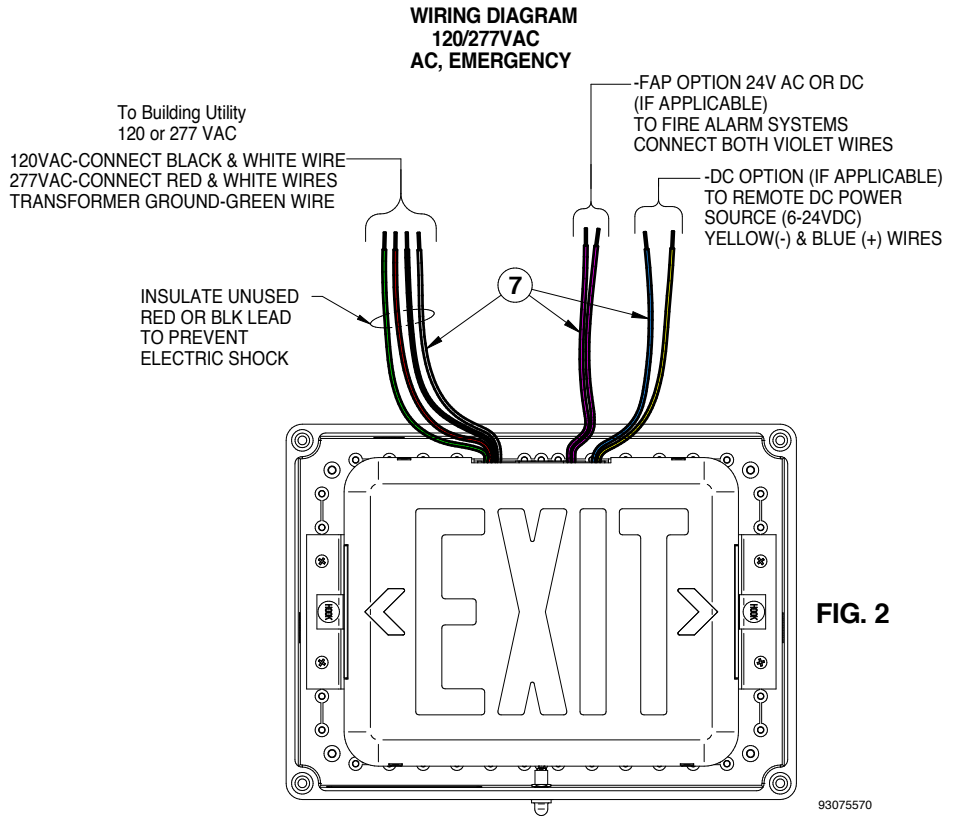

FIG. 2

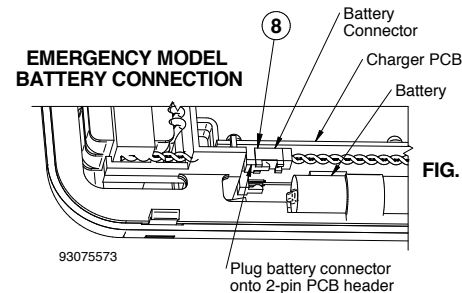

FIG. 3

IMPORTANT: This sign may be equipped with one or more options. Check model number suffix for option designation.

- FAP OPTION (Fire Alarm Panel) FAP option connects to 24 volts AC or DC (purple wires). Flash Rate .5 seconds on, .5 seconds off.
- DC OPTION (-DC Remote Option) DC Remote option connects to 6-24 volt DC Yellow(-), blue (+).
- FM OPTION (Flasher Module) Emergency Mode Flash Rate: .5 seconds on, .5 seconds off.

