



CLASS 8503 TYPE MGO-1 NEMA SIZE 5, 300 AMPERE, AC CONTACTOR SINGLE POLE, NORMALLY OPEN, SERIES A

DESCRIPTION

The Class 8503 Type M Line-Arc[®] contactor is an ac magnetic, mill type, clapper device and is designed to meet NEMA Standards. The double pole contactor consists of two single pole contactors mechanically tied together with the dc operating coils connected in series.

CONTACTOR RATINGS - MAXIMUM

600 volts ac 60 Hertz 40°C Ambient

Open 6 Hour Ratings		Enclosed Ratings		Crane Ratings	
AC Amperes	AC Amperes	AC Motor Horsepower 460 vac	AC Amperes	AC Motor Horsepower 460 vac	AC Motor Horsepower 460 vac
300	270	200	400	300	

OPERATING COILS DATA

DC Voltage Rating	Coil Part No.	Nominal OHMS At 20°C
115 / 120	D5-1017-056-51	407

The operating coils are designed in accordance with NEMA Standards to withstand 110% of rated voltage continuously and to operate the contactor successfully at 80% of rated voltage. Standard coil voltages are 115/120 volt dc. For other available coil voltages refer to Class 9998 Coil Data Catalog Sheet.

ELECTRICAL INTERLOCKS

Electrical interlocks are rated in accordance with NEMA Standard ICS-2-125 (A600 and N600 Table Ratings).

A600	Maximum Continuous Amperes	Maximum Make and Break Current Amperes							
		120V		240V		480V		600V	
		Make	Break	Make	Break	Make	Break	Make	Break
AC	10	60	6	30	3	15	1.5	12	1.2

N600	Maximum Continuous Amperes	Maximum Make and Break Current Amperes					
		125V		250V		600V	
		Make	Break	Make	Break	Make	Break
DC	10	2.2	2.2	1.1	1.1	.4	.4

Electrical interlocks consist of stationary contacts mounted on the contact arm support (23) and moving contacts attached to the bottom of the contact arm (22). A set of electrical interlocks contains one normally open and one normally closed double break contacts. Make and break ratings apply for double-throw contacts only when both the normally open and normally closed contacts are connected to the same polarity.

CONTACT TIPS

The movable and stationary power contact tips are identical. Copper power contact tips are standard. Silver faced power contact tips are available and are recommended for applications where the contactors remain closed for long periods of time. Silver-faced contact tips are standard on crane manual magnetic disconnect switches and are optional on dc starters.

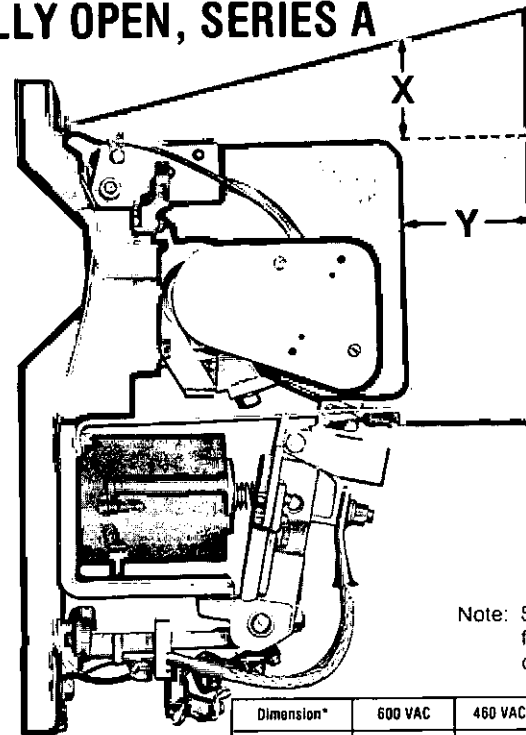

Note: Shaded area for arcing clearances.

Dimension*	600 VAC	480 VAC	230 VAC
X	2"	2"	2"
Y	6"	3"	2"

Figure 1

* To grounded, uninsulated panel
Electrical Clearances

INSTALLATION

1. Unpack contactor carefully. Remove shipping tape (if used).
2. Check nameplate data for correct equipment. Check that the contactor operating coil (39) is the correct voltage.
3. Check that all parts are undamaged and secure.
4. Mount the contactor vertically on a rigid support and fasten down tightly using a plain washer against the contactor base. Provide the clearance shown in Fig. 1 above the top of the contactor and in front of the arc chute for pivoting or removal of the arc chute and for electrical clearances.
5. With all power removed, mount auxiliary devices such as mechanical or electrical interlocks, if used, on contactor. Install and adjust these auxiliary devices by the procedure in the instruction sheets provided with the devices.
6. With all power removed, pivot the arc chute upwards and operate the contactor by hand. Check the alignment of the contact tips (10) by the procedure in the ADJUSTMENT—Contact Tip Alignment instructions in this Service Bulletin.
7. Pivot the arc chute back to its proper position.

CAUTION: DO NOT OPERATE THE CONTACTOR UNDER LOAD UNLESS THE ARC CHUTE IS PIVOTED TO THE FULLY DOWN POSITION.

8. Check the wiring diagram before connecting the contactor coil leads, power contact leads, and interlock leads. The operating coil circuit voltage may be different from the power circuit voltage.

CAUTION: FAILURE TO CONNECT THE OPERATING COIL TO THE PROPER VOLTAGE MAY RESULT IN IMPROPER CONTACTOR OPERATION OR DAMAGE TO THE COIL.

WARNING: ALL METAL PARTS OF THE CONTACTOR MAY BE AT LINE VOLTAGE. ALL POWER MUST BE DISCONNECTED FROM THE CONTACTOR BEFORE PERFORMING ANY ADJUSTMENT, MAINTENANCE OR TROUBLESHOOTING PROCEDURES.

ADJUSTMENT

CONTACT TIP ALIGNMENT

1. With all power removed, pivot the arc chute upward.
2. Check that the movable contact tip is against the ridge located on the auxiliary arm (13) (Fig. 2).

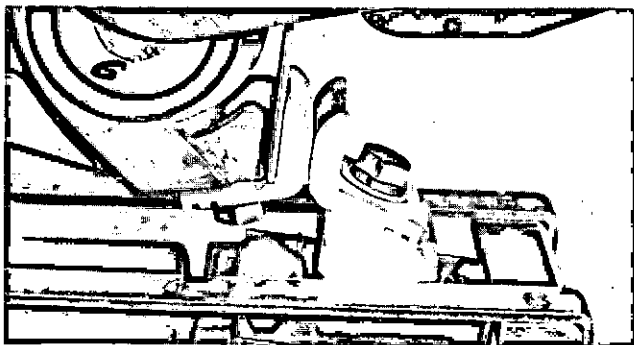

Figure 2

3. Check that the stationary contact tip is against the stationary contact support located on the blowout coil assembly (2) (Fig. 2).
4. Check that the contact tip surfaces are aligned both vertically and horizontally (Fig. 2).
5. Check adjustment of the mechanical interlocks by the procedure listed in the ADJUSTMENT-Mechanical Interlock instructions in this Service Bulletin.
6. Pivot the arc chute back to its proper position.

CAUTION: DO NOT OPERATE THE CONTACTOR UNDER LOAD UNLESS THE ARC CHUTE IS PIVOTED TO THE FULLY DOWN POSITION.

ELECTRICAL INTERLOCKS

1. With all power removed, check that the electrical interlock (49) has the proper follow-up. With new electrical interlock contacts, the moving contacts (52) should provide at least 1/16" follow-up on each stationary contact when the contact arm reaches its limit of travel; either completely closed or completely opened (Fig. 3).
2. Check that the normally closed electrical interlock contacts open before the power contact tips close.
3. Electrical interlock follow-up can be adjusted by bending the stationary contacts (56 & 57).

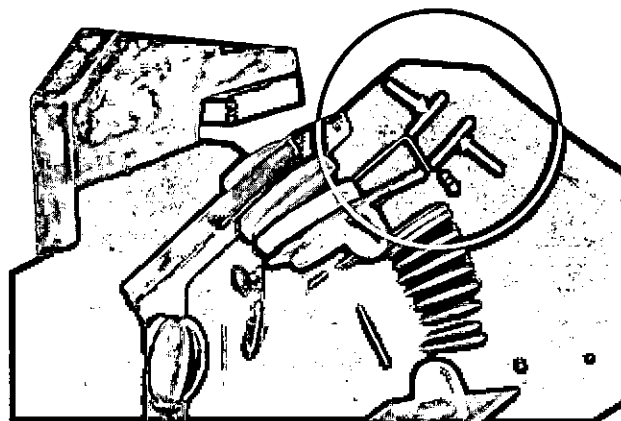

Figure 3

MECHANICAL INTERLOCK

1. With all power removed, check that the mechanical interlock allows the contact arm (22) of either contactor to reach its limit of travel, either completely closed or completely open, without binding.
2. Hold the contact arm of the left contactor fully closed and push closed the contact arm of the right contactor until stopped by the mechanical interlock. Check that there is a gap of at least 1/32" but not more than 1/16" between the inside edge of the stop bracket (44) and the back surface of the auxiliary arm (13) (Fig. 4).

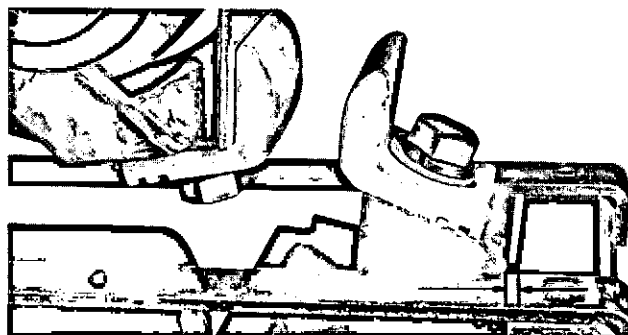

Figure 4

3. If the gap is not within the limits, adjust the mechanical interlock as follows: Loosen the two screws that hold the mechanical interlock to the stop bracket and move the mechanical interlock until the desired gap is achieved.
4. Repeat steps 2 and 3 above holding the right contactor in the fully closed position.
5. Push in one contactor to the kiss position and check that the other contactor does not come to the kiss position at the same time.
6. If both contactors come to the kiss position at the same time, repeat steps 2 to 5 decreasing the gap but still maintaining at least 1/32".
7. Again check that the mechanical interlock allows the contact arm of either contactor to reach its limit of travel, either completely closed or completely open, without binding.

WARNING: ALL METAL PARTS OF THE CONTACTOR MAY BE AT LINE VOLTAGE. ALL POWER MUST BE DISCONNECTED FROM THE CONTACTOR BEFORE PERFORMING ANY ADJUSTMENT, MAINTENANCE OR TROUBLESHOOTING PROCEDURES.

MAINTENANCE

LUBRICATION

No lubrication is required. The contactor is supplied with permanently lubricated oil impregnated bearings.

CONTACT TIP INSPECTION

The contact tips should be replaced when the contact follow-up is less than 1/16" (Fig. 5).



Figure 5

CONTACT TIP REPLACEMENT

1. With all power removed, pivot the arc chute upward.
2. Remove the movable contact tip by removing the silicon bronze hex head cap screw (11) and lockwasher (12) located on auxiliary arm (13).
3. Remove the stationary contact tip by removing the silicon bronze hex head cap screw (11) and lockwasher (12) located on blowout coil assembly (2).
4. Install the new stationary contact tip using the silicon bronze hex head cap screw, lockwasher, and washer.
5. Install the new movable contact tip using the silicon bronze hex head cap screw, lockwasher, and washer.
6. Manually operate the contactor and check the contact tips for alignment, by the procedure in the ADJUSTMENT—Contact Tip Alignment instruction in this Service Bulletin.

CAUTION: CHECK THE ADJUSTMENT OF THE MECHANICAL INTERLOCK.

7. Pivot the arc chute back to its proper position.

CAUTION: DO NOT OPERATE THE CONTACTOR UNDER LOAD UNLESS THE ARC CHUTE IS PIVOTED TO THE FULLY DOWN POSITION.

COIL REPLACEMENT

1. With all power removed, disconnect the coil leads.
2. Disconnect the top end of the shunt (21) by removing hex head nut (20), lockwasher (48), washer (19) and the shunt.
3. Remove the contact arm pin (24) by removing the hex head nut (20), lockwasher (48), and set screw (26).
4. Remove the contact arm assembly (22).
5. Remove the silicon bronze hex head cap screw (35) on the front of the magnet core and remove the lockwasher (36), core cap spacer (37), core cap (38) and coil (39).
6. Install the new coil using the core cap, core cap spacer and lockwasher and tighten the silicon bronze hex head screw. Note that the steel core cap, which is thicker than the non-magnetic phosphor bronze spacer, must

be installed against the coil. (See Exploded View). Check that the spring washer (40) is so positioned that the outside edge is against the coil and not against the magnet frame (41).

7. Replace the contact arm. Check that opening spring (29) is seated properly over hex head cap screw (35).
8. Replace contact arm pin and tighten set screw and hex head nut.
9. Check that auxiliary arm pin (27) is centered and set screw (18) is tight.
10. Connect the top end of shunt by replacing washer, lockwasher and hex head nut.
11. Reconnect the coil leads.

CAUTION: CHECK CONTACT TIP ALIGNMENT AND THE ADJUSTMENT OF THE MECHANICAL INTERLOCK.

ARC CHUTE REPLACEMENT

1. With all power removed, disconnect the arc chute wires by removing the hex head cap screw (47), washer (19), lockwasher (48), arc chute wires and shunt (21). (Fig. 6)
2. Disassemble the arc chute wires from the contactor base.
3. Remove the arc chute by removing hex head nut (17), lockwasher (8), hex head cap screw (45) and the arc chute.
4. Install the new arc chute using hex head cap screw and lockwasher and secure with hex head nut.
5. Reposition the arc chute wires along the contactor base.
6. Reconnect arc chute wires (Fig. 6) and shunt, using the washer, lockwasher and hex head cap screw.

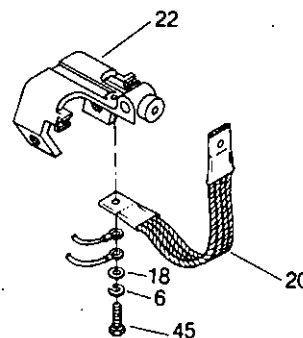

Figure 6

CAUTION: SHUNT MUST BE DIRECTLY AGAINST CONTACT ARM SUPPORT TO PROVIDE PROPER CONNECTION.

7. Rotate arc chute back to its proper position.

CAUTION: DO NOT OPERATE THE CONTACTOR UNDER LOAD UNLESS THE ARC CHUTE IS PIVOTED TO THE FULLY DOWN POSITION.

SHUNT REPLACEMENT

The shunt (21) should be replaced when the flexible braided wires are broken or burned or if the wires are loose in the terminal connectors on either end of the shunt.

1. With all power removed, disconnect the bottom end of the shunt (21) by removing hex head cap screw (47),

lockwasher (48), washer (19), arc chute wires and shunt. (Fig. 6)

2. Disconnect the top end of the shunt (21) by removing hex head nut (20), lockwasher (48), washer (19) and the shunt.
3. Check that auxiliary arm pin (27) is centered and set screw (18) is tight.
4. Install the new shunt. Connect the top end of the shunt by replacing washer, lockwasher and hex head nut.
5. Connect the bottom end of the shunt by replacing the shunt, arc chute wires, washer, lockwasher and hex head cap screw (Fig. 6).

CAUTION: SHUNT MUST BE DIRECTLY AGAINST CONTACT ARM SUPPORT TO PROVIDE PROPER CONNECTION.

6. Pivot the arc chute back to its proper position.

CAUTION: DO NOT OPERATE THE CONTACTOR UNDER LOAD UNLESS THE ARC CHUTE IS PIVOTED TO THE FULLY DOWN POSITION.

ELECTRICAL INTERLOCK REPLACEMENT

The electrical interlock contact tips should be replaced when inspection of the contacts shows that they are burned or badly pitted. It is recommended that the entire electrical interlock assembly be replaced from a kit. However, the contact tips only can also be replaced. Note position of the leads so they can be replaced.

Electrical Interlock Assembly Replacement

1. With all power removed, loosen terminal clamps and screws and remove terminal leads from the stationary contact assembly (57). Note position of the leads so they can be properly replaced.
2. Remove the movable contact assembly by removing the slotted screw (50), lockwasher (51) and washer (59).
3. Remove the stationary contact assembly by removing the slotted screw (58).
4. Install new stationary contact assembly by replacing the stationary contact assembly slotted screw making sure to position stationary contact assembly as shown on the exploded view drawing.
5. Install new movable contact assembly by replacing the washers, lockwashers and slotted screws making sure to position movable contact assembly as shown on exploded view drawing.
6. Manually operate the contactor and check the moving contacts for follow-up by the procedure in the ADJUSTMENT—Electrical Interlock instructions in this Service Bulletin.
7. Replace the terminal leads.

Electrical Interlock Contact Tip Replacement

1. After the electrical interlock assembly has been removed from the contactor the contact tips can be replaced.
2. Remove both sets of movable contact tips (52) from the movable contact assembly by compressing the spring (54) and retainers (53) and sliding out the movable contact tips.

3. Install both sets of new movable contact tips by compressing the spring and retainers and sliding in the movable contact tips.
4. Remove both top stationary contact tips (57) from the stationary contact assembly by removing the screws and washers which hold them in place.
5. Remove the terminal clamps and screws from the top stationary contact tips (57).
6. Install both new top stationary contact tips by replacing the top stationary contact tips, screws, and terminal clamps and screws.
7. Remove both bottom stationary contact tips (56) from the stationary contact assembly by removing the screws and terminal clamps.
8. Install both new bottom stationary contact tips by replacing the bottom stationary contact tips, terminal clamps and screws.
9. Install the stationary and movable contact assemblies and manually operate the contactor and check the moving contacts for follow-up by the procedure in the ADJUSTMENT—Electrical Interlock instructions in this Service Bulletin.
10. Replace the terminal leads.

OPENING SPRING REPLACEMENT

1. With all power removed, pivot the arc chute upwards.
2. With all power removed, disconnect the top end of the shunt (21) by removing hex head nut (20), lockwasher (48), washer (19) and the shunt.
3. Slide out the contact arm pin (24) after removing the hex head nut (20), lockwasher (48) and set screws (26).
4. Remove the contact arm (22).
5. Remove the opening spring (29) by removing the two hex head cap screws (31), lockwasher (8), washers (32) and armature plate (30).
6. Install new opening spring by inserting the narrow end of the spring through the hole in the armature plate so that the wide end of the spring is between the armature plate and the contact arm.
7. Fasten the armature plate to the contact arm by using washers, lockwashers, and hex head cap screws.
8. Check that there is no gap between the armature plate and the contact arm. This indicates that the opening spring is properly seated between the armature plate and the contact arm.
9. Replace contact arm assembly. Check that opening spring is seated properly over hex head screw (35).
10. Replace contact arm pin and set screw, lockwasher, hex head nut and tighten set screw and hex head nut.
11. Connect the top end of the shunt by replacing washer, lockwasher and hex head nut.

CAUTION: CHECK CONTACT TIP ALIGNMENT AND THE ADJUSTMENT OF THE MECHANICAL INTERLOCK.

12. Pivot the arc chute back to its proper position.

CAUTION: DO NOT OPERATE THE CONTACTOR UNDER LOAD UNLESS THE ARC CHUTE IS PIVOTED TO THE FULLY DOWN POSITION.

WARNING: ALL METAL PARTS OF THE CONTACTOR MAY BE AT LINE VOLTAGE. ALL POWER MUST BE DISCONNECTED FROM THE CONTACTOR BEFORE PERFORMING ANY ADJUSTMENT, MAINTENANCE OR TROUBLESHOOTING PROCEDURES.

TROUBLESHOOTING

Refer to the Operating Coil Table in this bulletin for coil ratings.

Refer to Contactor Ratings in this bulletin for contactor ratings.

TROUBLE	POSSIBLE CAUSE	REMEDY
<p>Contacts will not open or operation is sluggish</p>	<ol style="list-style-type: none"> 1. Improper or defective operating coil. 2. Low control circuit voltage. 3. Loose connection in control circuit. 4. Mechanical interference or binding. 	<ol style="list-style-type: none"> 1. Check coil part number and resistance to determine if coil is defective. 2. Check that control circuit voltage is a minimum of 80% of rated coil voltage. If it is zero, the problem is elsewhere in the circuit. 3. Check connections and tighten if loose. 4. Check for mechanical interference or binding: <ol style="list-style-type: none"> a. Check mechanical interlock interference by disconnecting it from the contactor that is binding. Refer to ADJUSTMENT—Mechanical Interlock instructions in this Service Bulletin. b. Check that the tie bar is not causing binding. c. Manually close the contact arm and check that cap screw head on core of magnet frame assembly clears the hole in the armature plate. d. Manually close the contact arm, check that the auxiliary arm bearings are not binding.
<p>Contact tips overheating, short contact tip life.</p>	<ol style="list-style-type: none"> 1. Loose connections. 2. Movable or stationary contact tip not properly aligned. 3. Foreign matter on contact surfaces. 4. Contact tips worn beyond recommended limits. 5. Contact surfaces severely scored or burned. 6. Arc chute not properly installed. 7. Defective opening spring. 	<ol style="list-style-type: none"> 1. Check contact tips and shunt connections and tighten if loose. 2. Check the alignment of the contact tips by the procedure listed in the ADJUSTMENT—Contact Tip Alignment instructions in this Service Bulletin. 3. Remove foreign matter. 4. Check for contact wear by the procedure listed in the MAINTENANCE—Contact Tip Replacement instructions in this Service Bulletin. 5. Inspect contact surfaces and dress with a file as required. Check that the arc chute wires are connected to the contact arm support and are not broken. 6. Check that arc chute is pivoted to the fully down position. 7. Replace the spring.
<p>Operating Coil Overheats</p>	<ol style="list-style-type: none"> 1. Improper or defective coil. 2. High voltage condition on coil. 3. Loose connection at coil terminals. 	<ol style="list-style-type: none"> 1. Check coil part number and resistance to determine if coil is defective. 2. Check that control circuit voltage does not exceed 110% of rated coil voltage. 3. Check connection and tighten if loose.

**PARTS LIST FOR CLASS 8503 TYPE MGO-1 NEMA SIZE 5, 300 AMPERE, AC CONTACTOR
SINGLE POLE, NORMALLY OPEN, SERIES A**

Item No.	Part No. ■	Description	Item No.	Part No. ■	Description
1	C51019-217-52	Arc Chute			Head Cap Screw (1 Req'd.)
2	C51019-287-50	Blowout Coil Assembly	36		5/16 Silicon Bronze Lockwasher (1 Req'd.)
3	B51019-237-01	Blowout Coil Guard	37	B50502-006-11	Core Cap Spacer (Phosphor Bronze)
4		1/4 - 20 x 1/2 Pan Head Screw With Captive Lockwasher (5 Req'd.)	38	B50502-006-10	Core Cap (Steel)
5		1/4 - 20 x 7/8 Slotted Hex Head Cap Screw (2 Req'd.)	†39	D51019-243-56	Operating Coil (115/120 vdc)
6		1/4 Lockwasher (2 Req'd.)	40	A51019-041-01	Spring Washer
7		5/16 - 18 x 1 Slotted Hex Head Cap Screw (2 Req'd.)	41	B51019-223-50	Magnet Frame
8		5/16 Lockwasher (10 Req'd.)	42	E51019-238-50	Contact Base
9	21203-20120	1/4 - 20 x 3/8 Flat Head Brass Screw (1 Req'd.)	43		5/16 - 18 x 1/2 Slotted Hex Head Cap Screw (2 Req'd.)
†10	A50005-010-01 or Class 9998 Type MG-1 or Class 9998 Type MG-2	Contact Tip (Copper) Contact Tip Kit (Copper) consisting of: 2 - Sets of Tips and Hardware	44	B51019-256-50	Stop Bracket
11	21407-24280	Contact Tip Kit (Silver) consisting of 2 - Sets of Tips and Hardware	45		5/16 - 18 x 2 1/2 Hex Head Cap Screw
12	23711-22400	3/8 - 16 x 7/8 Silicon Bronze Hex Head Cap Screw (2 Req'd.)	46		5/16 - 18 x 3/4 Slotted Hex Head Cap Screw (2 Req'd.)
13	B51019-255-50	3/8 Silicon Bronze Lockwasher (2 Req'd.)	47	21401-24280	3/8 - 16 x 7/8 Hex Head Cap Screw
14	B50502-602-44	Auxiliary Arm	48	23701-00240	3/8 Lockwasher
15	B51019-239-01	Auxiliary Arm Spring	†49	Class 9999 Type MX-11 or C51075-038-54	Electrical Interlock Kit
16		Auxiliary Arm Spring Retainer			Bulk Package of Replacement Electrical Interlock Contacts includes: 10 - Movable Contact Tip (Item 52) 10 - Bottom Stationary Contact Tip (Item 56) 10 - Top Stationary Contact Tip (Item 57) 4 - Spring Retainer (Item 53) 2 - Spring (Item 54)
17		5/16 - 18 x 1 1/4 Hex Head Cap Screw (1 Req'd.)	50		#10 - 24 x 1 Pan Head Screw (2 Req'd.)
18	21802-24640	5/16 - 18 Hex Head Nut (2 Req'd.)	51		#10 Lockwasher (2 Req'd.)
19		3/8 - 16 x 2 Headless Slotted Half Dog Point Set Screw	52		Movable Contact Tip (2 Req'd.)
20		3/8 Plain Washer (2 Req'd.)	53		Spring Retainer (2 Req'd.)
21	B51019-204-50	3/8 - 16 Hex Head Nut (2 Req'd.)	54		Spring
22	B51019-214-50	Shunt (Connector)	55		#10 - 24 x 1/2 Pan Head Screw With Captive Lockwasher (1 Req'd.)
23	C51019-230-01	Contact Arm	56		Bottom Stationary Contact Tip (2 Req'd.)
24	A51019-251-06	Contact Arm Support	57		Top Stationary Contact Tip (2 Req'd.)
25	29005-32220	Contact Arm Pin	58		#10 - 24 x 1/2 Captive Screw Assembly With Long Shank and Captive Lockwasher (1 Req'd.)
26	21802-24320	Bearing (2 Req'd.)	59		#10 Plain Washer (3 Req'd.)
27	A51019-251-05	3/8 - 16 x 1 Headless Slotted Half Dog Point Set Screw			
28	29005-24161	Auxiliary Arm Pin			
29	B50502-602-13	Bearing (2 Req'd.)			
30	A51019-234-01	Opening Spring			
31		Armature Plate			
32		5/16 - 18 x 5/8 Hex Head Cap Screw (2 Req'd.)			
33		5/16 Plain Washer (2 Req'd.)			
34		Nameplate			
35		#6 - 32 x 1/4 Pan Head Screw (2 Req'd.)			
		5/16 - 18 x 3/4 Silicon Bronze Hex			

■ Standard hardware, listed without Square D Part Number, should be obtained from a local hardware supplier.
† Parts Recommended for General Maintenance.

