

K-REEL SEAL KIT

DISASSEMBLY/ASSEMBLY PROCEDURE

INSTRUCTIONS

1. Remove hoses and adapter fittings from swivel joint.
2. While holding reel spool stationary, loosen swivel joint by turning hex on stem of swivel joint. After threads have disengaged, remove swivel joint by pulling straight out to avoid damage to center tube.
3. Remove center tube by pulling straight out.
4. Remove "O" rings from center tube. Clean tube thoroughly and install new "O" rings on each end.
5. Remove snap ring from swivel joint.
6. Remove swivel joint from barrel by gently tapping on end of stem.
7. Remove dust seals, back-up rings and "O" rings. Take care not to scratch stem.
8. Clean stem and barrel thoroughly and inspect for excessive wear.
9. Install new dust seals, "O" ring seals and back-up rings, starting with the dust seal on the threaded end of the stem. **NOTE: Back-up rings must be on the outboard side of the "O" ring seals** (see detail, right).
10. Lubricate seals with lubricant compatible with media.
11. Gently install stem into tapered lead-in end of barrel. This must be done by hand.
12. Install snap ring.
13. Reinstall center tube and swivel onto reel.

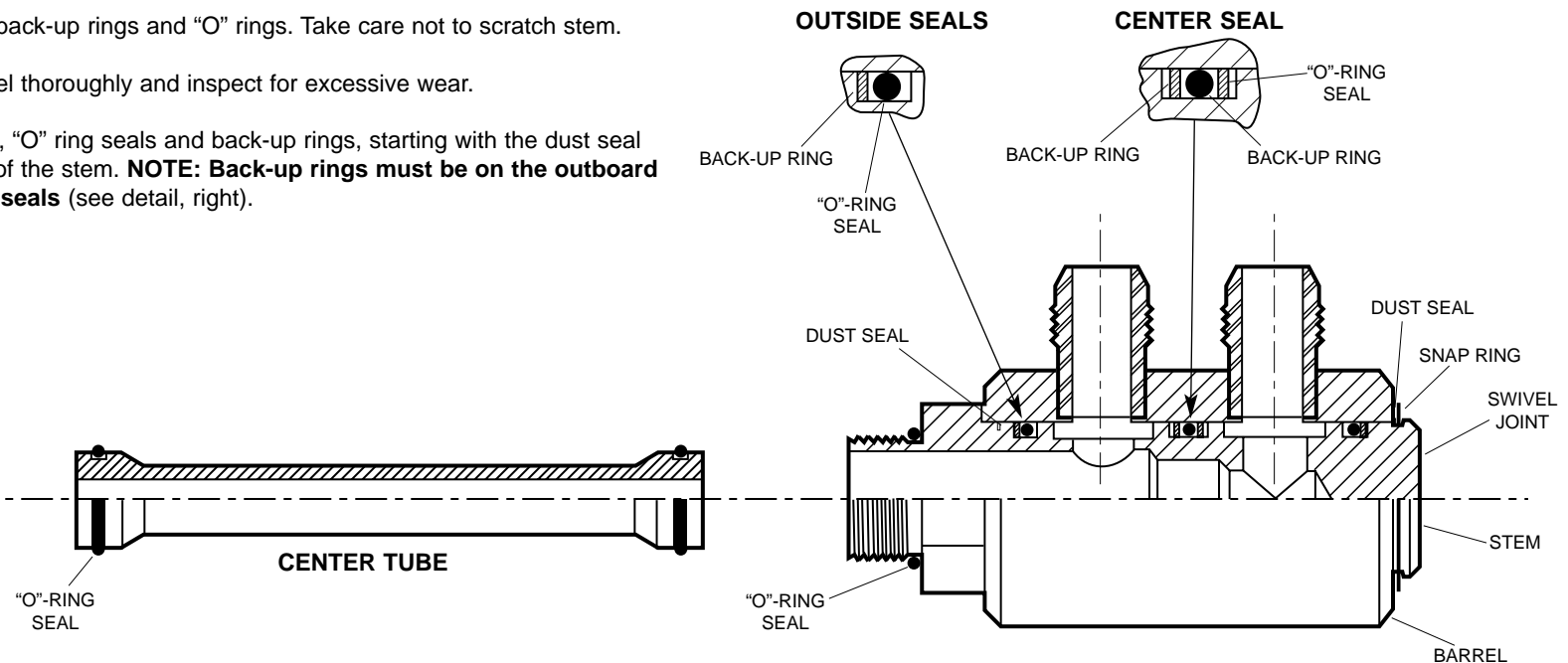

GLEASON REEL CORP.
 600 South Clark St.
 Mayville, WI 53050-0026
 Phone 920-387-4120
 Fax 920-387-4189