

# GLEASON® PowerTrak®

## E Type Model PT55E-WH Parts List

ITEM	DESCRIPTION	PART NO.
1	Outer Link	P55E-98
2	Inner Link—11.22 radius	P55E-01
	" 15.00 radius	P55E-02
	" 18.69 radius	P55E-03
	" 24.31 radius	P55E-04
	" 30.00 radius	P55E-05
	" 36.00 radius	P55E-06
3	Anti-friction Plate	028054
4 – 6	—See Below—	
7	Hinge Pin	P04-74
8	Retaining Ring	111538
9	Shim Washer, 1.03 ID x .01 thick	028915
10	Shim Washer, 1.03 ID x .02 thick	028916
11	Skt. Hd. CSCR, M6-1.0 x 16	028920
12	Lockwasher, M6	028912
13	Mounting Bracket, L.H.	P07-331
14	Mounting Bracket, R.H.	P07-332

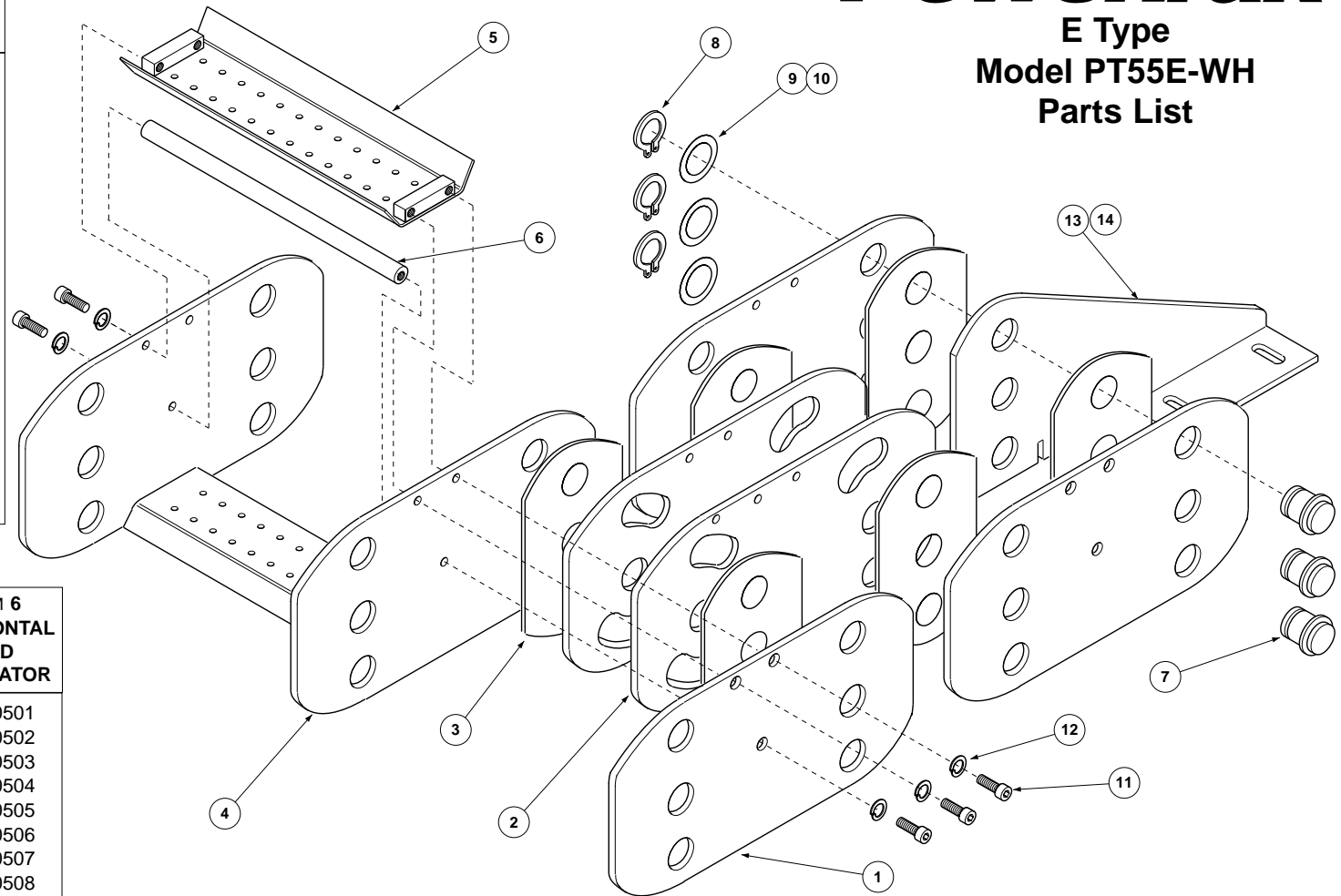

CARRIER WIDTH	ITEM 4 CHANNEL WELDMENT	ITEM 5 CHANNEL CARRIER	ITEM 6 HORIZONTAL ROD SEPARATOR
6.00"	02890001	02889501	02890501
8.00"	02890002	02889502	02890502
10.00"	02890003	02889503	02890503
12.00"	02890004	02889504	02890504
14.00"	02890005	02889505	02890505
16.00"	02890006	02889506	02890506
18.00"	02890007	02889507	02890507
20.00"	02890008	02889508	02890508
22.00"	02890009	02889509	02890509
24.00"	02890010	02889510	02890510



**GLEASON REEL CORP.**  
600 South Clark St.  
Mayville, WI 53050-0026  
Phone 920-387-4120 • Fax 920-387-4189