

GLEASON PowerTrak®

E-Type Model PT25E-TB Parts List

ITEM	DESCRIPTION	PART NO.
1	Outer Link	P01-114
2	Inner Link - 2.95 radius	P01-115
	5.16 radius	P01-116
	8.00 radius	02682501
	11.72 radius	P01-117
3	Anti-Friction Disc	025692
4	Hinge Pin	058503
5	E-Ring	102261
6	Alum. Channel - 4.00" lg.	02705701
	6.00" lg.	02705702
	8.00" lg.	02705703
	10.00" lg.	02705704
	12.00" lg.	02705705
7	Whiz-Lock Screw	027396
8	LH Mounting Bracket	P07-207
9	RH Mounting Bracket	P07-208
10	#10 Int Tooth Lockwasher	022453
11	#10-32 UNC Hex Nut	100938
12	Spacer Plate	045554
13	Retainer with Pem Stud	045556

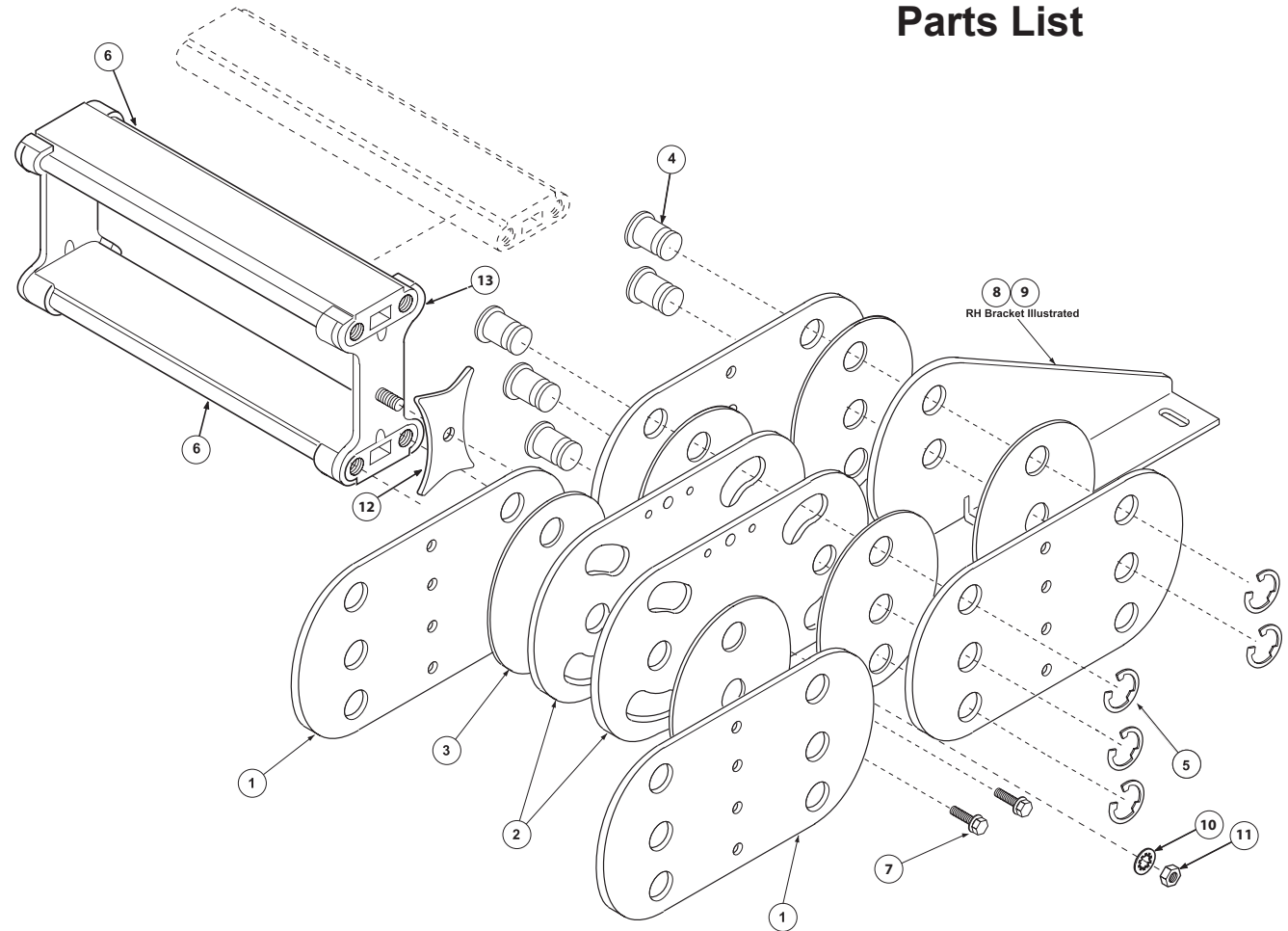

SIDE CHAIN ASSEMBLY

(Includes items 1 - 5)

Qty. 1 = one 1 ft. section

for one side only.

L.H. and R.H. chains are identical.

RADIUS	PART NO.
2.95	09185101
5.16	09185102
8.00	09185103
11.72	09185104

PowerTrak Splice Kit P/N **034417** includes:
(6) hinge pins, (4) anti-friction discs, and
(12) E-ring fasteners



GLEASON REEL CORP.

600 South Clark St.
Mayville, WI 53050
Phone: 920-387-4120
Fax: 920-387-4189
www.hubbell-gleason.com