

# GLEASON PowerTrak®

## E-Type Model PT28E-TB Parts List

ITEM	DESCRIPTION	PART NO.
1	Outer Link	P28E-00
2	Inner Link - 2.95 radius	P28E-01
	4.53 radius	P28E-03
	6.10 radius	P28E-05
3	Anti-Friction Disc	026727
4	Hinge Pin	058503
5	E-Ring	102261
6	Alum. Channel - 4.00" lg.	02705701
	6.00" lg.	02705702
	8.00" lg.	02705703
	10.00" lg.	02705704
	12.00" lg.	02705705
	7	Whiz-Lock Screw
8	LH Mounting Bracket	P07-219
9	RH Mounting Bracket	P07-220
10	#10 Int Tooth Lockwasher	022453
11	#10-32 UNC Hex Nut	100938
12	Spacer Plate	045555
13	Retainer with Pem Stud	045557

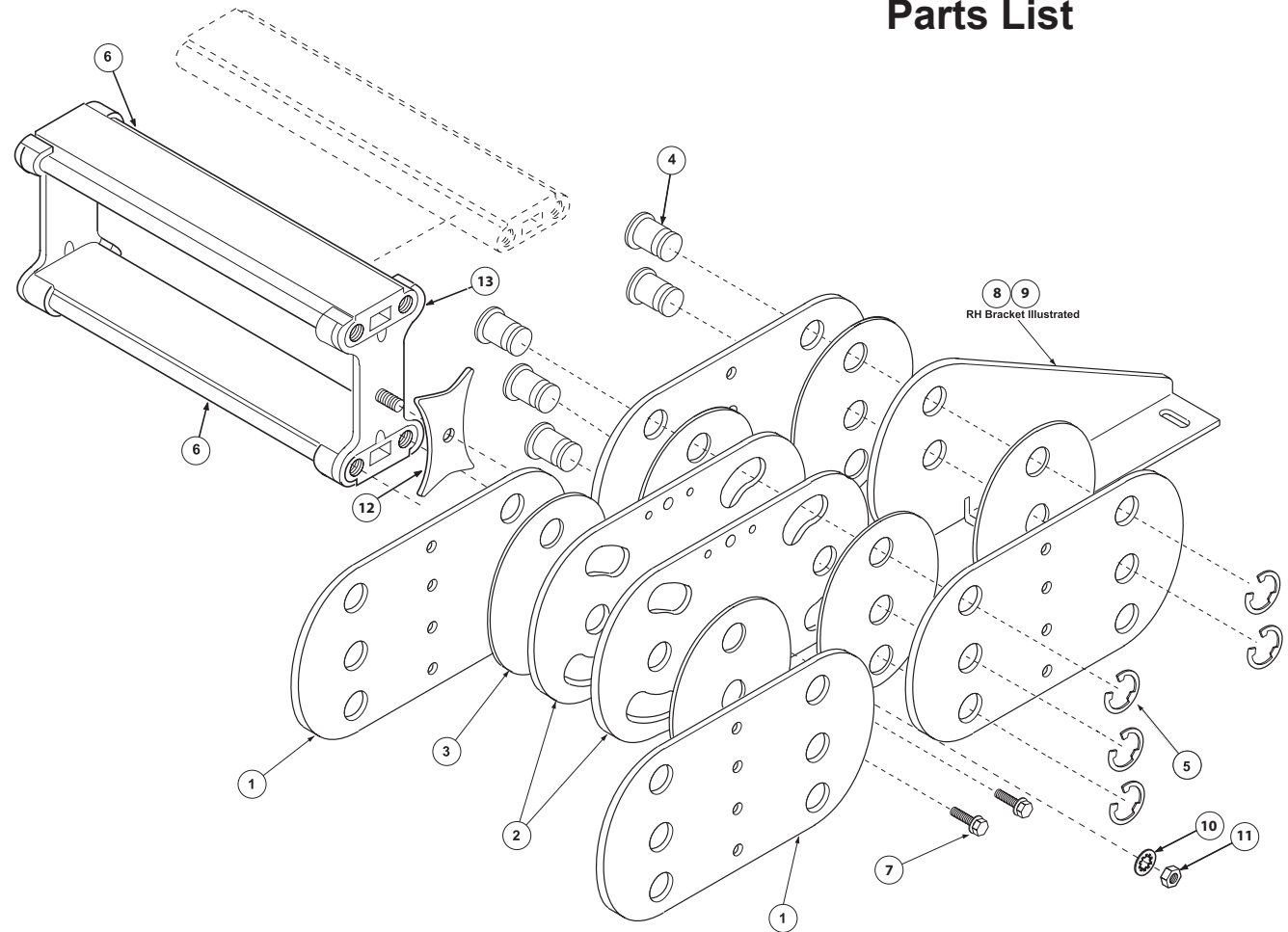

SIDE CHAIN ASSEMBLY (Includes items 1 - 5) Qty. 1 = one 1 ft. section for one side only. L.H. and R.H. chains are identical.	
RADIUS	PART NO.
2.95	09185201
3.74	09185202
4.53	09185203
5.31	09185204
6.10	09185205
7.87	09198506

PowerTrak Splice Kit P/N **034418** includes:  
(6) hinge pins, (4) anti-friction discs, and  
(12) E-ring fasteners



**GLEASON REEL CORP.**  
600 South Clark St.  
Mayville, WI 53050  
Phone: 920-387-4120  
Fax: 920-387-4189  
[www.hubbell-gleason.com](http://www.hubbell-gleason.com)