

GLEASON PowerTrak®

E-Type Model PT35E-T1 Parts List

ITEM	DESCRIPTION	PART NO.
1	Outer Link	P01-118
2	Inner Link - 5.22 radius	P01-119
	7.50 radius	P01-120
	11.12 radius	P01-121
	15.00 radius	P01-122
	24.31 radius	P01-123
3	Anti-Friction Disc	025693
4	Hinge Pin	058504
5	E-Ring	048686
6	Alum. Channel - 4.00" lg.	02705801
	6.00" lg.	02705802
	8.00" lg.	02705803
	10.00" lg.	02705804
	12.00" lg.	02705805
	14.00" lg.	02705806
	16.00" lg.	02705807
7	Whiz-Lock Screw	106144
8	LH Mounting Bracket	P07-209
9	RH Mounting Bracket	P07-210
10	.25 Int Tooth Lockwasher	102602
11	.25-20 UNC Hex Nut	100942
12	Retainer with Pem Stud	045524
13	Channel Separator	043674

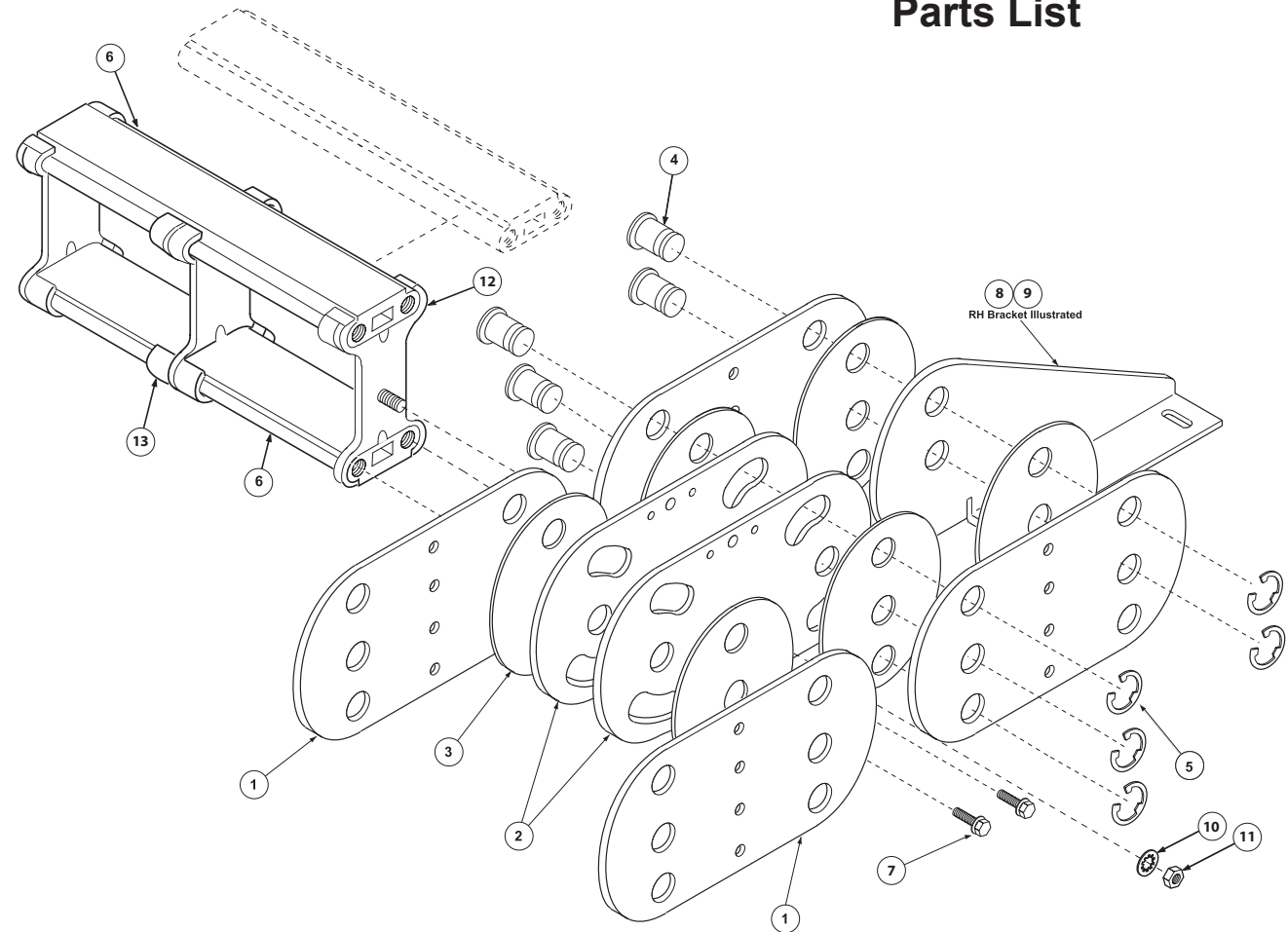

SIDE CHAIN ASSEMBLY

(Includes items 1 - 5)

Qty. 1 = one 1 ft. section

for one side only.

L.H. and R.H. chains are identical.

RADIUS	PART NO.
5.22	09185301
7.50	09185302
11.12	09185303
15.00	09185304
24.31	09185305

PowerTrak Splice Kit P/N **034419** includes:
(6) hinge pins, (4) anti-friction discs, and
(12) E-ring fasteners



GLEASON REEL CORP.

600 South Clark St.
Mayville, WI 53050
Phone: 920-387-4120
Fax: 920-387-4189

www.hubbell-gleason.com