



SERIES GRP NYLON POWERTRAK® CHAIN

Installation & Operation Instructions

BEFORE YOU BEGIN installing your GRP PowerTrak Chain and Guide Trays, please read through these Instructions completely! Refer to the last page for important information about installing your cable and hose conductors. Refer to your General Arrangement drawing (when supplied) for the overall system layout, mounting dimensions, space requirements, travel distance, and other application information. Contact the factory if you have any questions or concerns about your PowerTrak Chain or Guide Trays installation.

INSTALLATION & OPERATION

The PowerTrak carrier system requires a level, rigid support for proper operation. A retaining tray to guide and support the lower chain section is recommended. Ambient temperature of +50°F or higher is recommended while working with the PowerTrak Chain.

When trays are required to guide and support the PowerTrak chain for long travel distances:

1.a Position and fasten the individual tray sections together as shown on the accompanying general arrangement drawing. All tray joints must be butted together tightly and the inside walls and bottom surfaces must be flush. **DO NOT** secure the trays to the mounting surface at this time! The trays shall be supported at five-foot intervals (maximum) throughout the entire length of the tray system **AND** within one foot distance from all tray joints.

1.b If a general arrangement drawing was not supplied with the PowerTrak chain, please contact the factory for instruction to properly arrange the different tray types to insure proper installation of the guide trays.

2.a If the cables and hoses can be pulled through the compartment of the chain, the chain can be placed into the guide tray at this time.

2.b Be certain the fixed end mounting brackets are oriented properly in the cable access tray section and anchor the brackets per step 4.

2.c If the cables and hoses must be placed in the chain compartment with access from the top, then lay the chain on a clean, flat surface so the snap-fit retaining bars can be accessed from the top-side of the link.

2.d Locate clip ends of the retaining bars (largest protrusion at one end of the bar). Release the clip from the link using 1/4" wide flat tip screwdriver. Insert the screwdriver beneath the end of the clip and gently twist until the bar "snaps" free and swings upward. **CAUTION:** Bend the Clip only enough to snap free from the side of the Link - too much deflection can fracture the Clip.

3.a Lay cables/hoses in the chain compartment, allowing sufficient length at each end for connections. Adjust the separator(s) as required and reinstall retaining bars as described below. If more convenient, bars may be turned around so they open on the opposite side of the chain.

3.b Carefully insert hook at one end of the bar into the upper area of the notch in the link side-wall. Swing the bar down so the clip at the far end of the bar will seat into the notch in the side of the link. Apply a downward force until the clip "snaps" into place. **DO NOT** hammer or stomp on the bar as this could damage the retaining bar!

3.c The top of the link side wall and the retaining bar should be flush. Check to make sure the bar is "snapped" securely into the link.

3.d Some PowerTrak chains may utilize a nylon split-bar insert at every second or third link to carry the cables and hoses. In most chains, these are installed before shipment. After removing the retaining bar, simply lift the upper half of the split-bar out of the link frame.

3.e Install the cables and hoses into their proper custom-machined compartments. Orient the top half of the split-bar to mirror the lower half already set in the link frame. Slide the bar into the link frame so the grooves at each end mate with the ribs on each side of the link.

3.f Install the retaining bars as described in step-3.b. The split-bar carrier will be captivated all around if properly installed and cannot be removed or knocked out of the surrounding link frame.

4. Secure the fixed end mounting brackets in the bottom of the cable access tray. **Do NOT** fasten to the rigid support beneath the tray at this time! Locate and drill mounting holes through the tray bottom using the brackets as a template. Be certain the PowerTrak chain is centered between the sides of the tray and the chain is directed down the center of the tray system during operation.

5. Fasten the movable end mounting brackets to the machine tow arm in direct (plumb) alignment with the fixed mounting brackets.

6. Complete all cable/hose terminations. The cables/hoses must not be twisted and shall be free of kinks or other irregularities. The basic rule for the maximum allowable cable/hose area utilized within the track compartment for uniform arrangements is 20 percent clearance (minimum inside dimensions = cable/hose diameter x 1.20). This allows for dimensional tolerances of the cables/hoses and insures freedom of movement to prevent erratic track operation and premature cable/hose failure.

7. Adjust cable/hose tension to help prevent twisting and premature wear. Cable/hose must lay within the loop section of the track in a relaxed condition—not pulled tight against the compartment frame—and follow a straight path through the entire length of the track. Secure the cables/hoses at both ends of the track, near the mounting brackets, to prevent any movement relative to the track.

8.a Operate the machine slowly throughout the total travel stroke and align the tray system directly beneath the moving mounting brackets. The brackets must center the chain between the sides of the tray system throughout the entire travel distance to provide smooth and free movement of the PowerTrak chain. Be certain the extreme ends of travel do not exceed the limits of the chain.

8.b Secure each tray section in at least two places to the supporting structure or floor. This may be done by welding or bolting through the bottom of the trays. You must use flat-headed countersunk screws so the inside surface is flush where the PowerTrak chain rests on the bottom of the trays. No mounting holes are furnished in the trays, so they must be drilled to match your mounting locations.

9. No lubrication is required. To clean the PowerTrak chain, periodically wash-down with water (do not allow to freeze) or blow dirt and debris away with air pressure.

10. Periodically inspect for cable/hose wear, track wear and breakage. Also check that track mounting brackets and cable/hose terminations are secure.

MATERIALS AND SERVICING GUIDE

Track length adjustment and replacement of damaged or worn parts can be accomplished by following these instructions very carefully. But first, a brief discussion of material and components will provide a better understanding.

All Series GRP PowerTrak components are injection molded of chopped fiberglass filled nylon resin with black colorant. Nylon (polyamide) is a crystalline plastic exhibiting excellent fatigue resistance, low coefficient of friction, good toughness, and resistance to a wide range of fuels and chemicals. Glass fiber reinforced compounds provide greater strength and stiffness with improved impact strength. Flame retardant nylon compounds are available with 94V-O classification.

All nylons absorb moisture which has proven to enhance certain properties of Series GRP PowerTrak chain. The moisture content decreases stiffness and increases elongation and impact resistance. When handling the chain during installation, length adjustments or part replacement, this resiliency is important in preventing part fracture or breakage due to abnormally high stresses which don't occur during normal track operation. This does not imply that nylon Series GRP PowerTrak is unbreakable, but it is an extremely tough, long wearing, lightweight, corrosion resistant, low cost method of containing electrical cables and hoses supplying power to machinery in motion.

Series GRP PowerTrak chain is designed to be simple to use, virtually maintenance free, and strong enough to be self-supporting for shorter travel lengths containing light to moderate payload weights. The resilient nature of the PowerTrak material will allow deflection of longer unsupported track lengths to permit sliding upon itself, finished steel or rollers within a steel tray designed for this purpose.

Series GRP PowerTrak components require no special tools for installation or servicing. You will only need a 1/4" wide flat tip screwdriver approximately 6" long. An additional 3/8" wide flat tip screwdriver is required for the larger chain sizes.

1. PART IDENTIFICATION

1.1 Link Frame – U-shaped body with a wide, ribbed beam molded integrally with the side plates. Side plates have holes and slots or holes and pins for joining link frames.

1.2 Link Caps (RH & LH) – For use on 263P and 354P chain sizes only. Discs with pins and arc-shaped bosses assembled to sides of track. Model number, RH or LH, and arrow pointing to track flexing radius are embossed on the caps. Link caps join all link frames together without pins, bolts, or rivets. A centrally located 2 or 3 jaw pin holds caps in place for a secure, reliable track assembly.

1.3 Retaining Bar – Removable, ribbed bar located at top (open end) of the link frame and held in place by a hook at one end and a clip at the other end. The bars are factory installed so the link compartment may be accessed from one side only. When removed, they can be flipped end for end so access is from the other side of the track. This is a unique feature to help ease compartment access of an installed track.

1.4 Separators – Adjustable partitions within the track compartment which separate cables/hoses so as to prevent cable/hose entanglement and act as a support column to strengthen load capacity of the retaining bar. Separators securely grip the link frame beam and cradle the retaining bar.

1.5 Bar Carriers (optional) – For use on 263P and 354P chain sizes only. Machined nylon bars contain cables/hoses on an individual basis. They are custom manufactured per specific payload requirements and increase cable/hose life by restricting movement within link compartment.

1.6 Mounting Brackets – Zinc plated steel brackets are secured to both ends of the chain for a strong, reliable assembly. The bracket on one end of the chain is bolted to the fixed (non-moving) support surface. The opposite end is bolted to a support arm on the moving machine. Brackets can be pivoted 90° for face mounting or inverted.

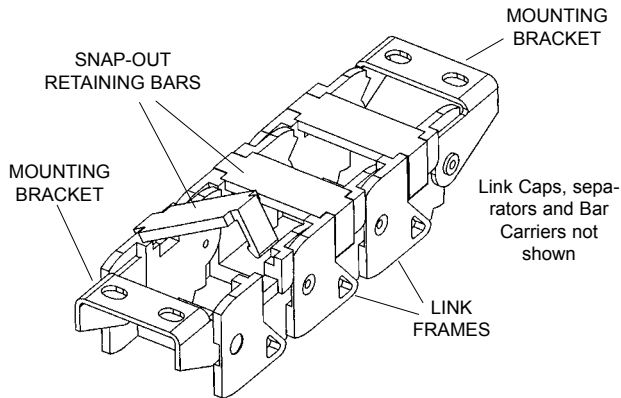

Use the following procedures to adjust track length, replace links or splice track sections. Adding or removing links when ambient temperature is lower than +50°F may produce material fractures. Warm material in hot tap water if required.

2. LINK REMOVAL (Models 263P & 354P only)

2.1 If track is lying within a guide tray, elevate and support track above tray or completely remove from tray to allow access to link caps on both sides of track.

2.2 Identify link joints to be disassembled and relieve joint stress by shimming track to establish a slight arc in the flexing direction.

2.3 Place a 1/4" screwdriver into the recess at the edge of each link disc. Gently pry the cap off by pushing the screwdriver tip between the kidney shaped bosses (visible as indentations on disc face) and the central holding jaws. NOTE: DO NOT force the blade directly toward the holding jaws at the center of the cap. An impact from the screwdriver may fracture the jaws.

2.4 Continue forcing the screwdriver blade beneath the link cap until it snaps free of the inner link side wall. A 90° twist of the screwdriver will lift the cap further. Rotate the cap in both directions to be sure it is free.

2.5 Position the 3/8" wide screwdriver tip adjacent to the holding jaws between the link cap and side wall. Twist the screwdriver gently using the width of the tip to pry off cap. DO NOT pry off cap by lifting on screwdriver handle (as a lever) because force applied at the outer rim could cause cap distortion or breakage.

2.6 Repeat steps 2.3 thru 2.5 for remaining link caps to be removed.

2.7 Remove the links as required.

3. LINK ASSEMBLY (Models 263P & 354P only)

TIP: Lay PowerTrak links on edge when assembling several links together and then assemble into track.

3.1 Select the proper radius and RH or LH side link cap by matching with other link caps in the track. If unsure of RH or LH, position links so you are looking into the end with the arc-shaped slots and the runners are at the bottom. The RH caps go onto the right side, the LH caps the left side.

3.2 Position link frames so the round holes at one end match up with the arc-shaped slots in the adjacent link and the relative angle formed at the runner side is slightly less than 180°. Be sure all links have the runners facing a common direction.

3.3 Position the link cap with the center jaws over the center hole of the link side wall. Rotate cap until protrusions on the cap are aligned with the holes in the inner link side wall.

3.4 Gently squeeze link cap and link side walls together with hands (apply evenly distributed force) until you hear the jaws snap into place. Be sure jaws “snap” through both outer and inner link walls. A properly installed link cap will be tight against outer link wall and will rotate with inner link wall.

3.5 Repeat steps 3.2 thru 3.4 for all link caps to be installed.

4. LINK REMOVAL AND ASSEMBLY (All other models)

4.1 Determine link(s) to be removed and insert blade of 1/4" wide flat tip screwdriver between link frame side walls. Gently pry apart until the outer wall pull free from the pin. If links cannot be separated, carefully repeat operation on the opposite side.

4.2 To assemble, match male and female ends of adjacent links and push together for a snap-fit.

NOTE: Some PowerTrak chains are available as riveted assemblies. Long sections are shipped in shorter lengths with additional pop-rivets and washers for splicing joints. For additional information contact Gleason Reel.

Cable and Hose Guidelines

Special attention must be given when installing cable or hose into PowerTrak chain. Below are a few considerations:

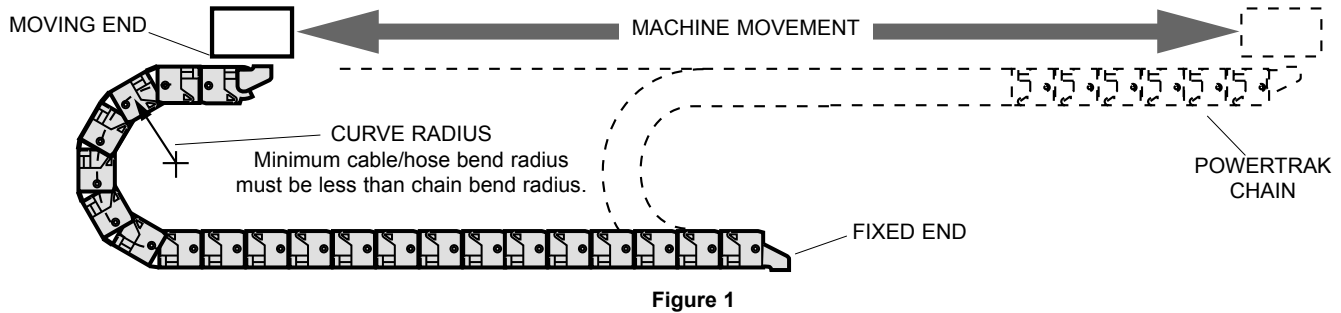

CABLE/HOSE SELECTION

1. Select cable or hose with minimum bend radius (MBR) less than bend radius of the chain. Follow cable or hose manufacturer's specifications and guidelines. See Figure 1.
2. Select cable that is rated "continuous flex". Cables built for robotics are designed to flex millions of times, but some only flex on one axis. Consult your supplier for complete cable specifications.
3. Be sure cable and hoses are suitable for use in anticipated operating environment. This is especially important in outdoor applications where sub-zero temperatures cause some cable or hose material to stiffen or even break.

INSTALLATION

1. The cables/hoses must not have twists, bends or kinks at the time of installation. Unspool (do not uncoil) cable or hose from shipping reel several hours in advance of installation. Hang cables and hoses for 24 hours or, at the minimum, lay out in straight line to allow kinks and curves to straighten out. See Figure 2.

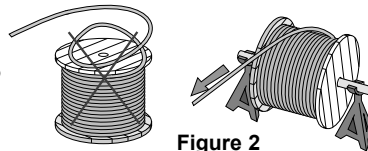

Figure 2

2. Arrange cables and hoses in the chain so that load is evenly

distributed across width with largest and/or heaviest cables/hoses located to the outer sides of the chain (Fig. 3). Use separators between different sizes of cables and hoses to maintain proper spacing and to reduce cable/hose jacket wear (Fig. 4). Do not place large cable or hoses in same compartment with small ones (Figs. 5 & 6).

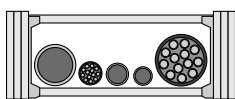

Figure 3

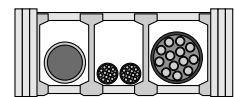

Figure 4

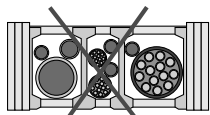

Figure 5

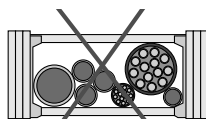

Figure 6

3. Arrange cables/hoses in the compartment so as to allow adequate movement. The largest cable or hose in the chain should have 20% clearance of the inside height and the total of all cables/hoses should have 20% clearance of the inside width (Fig. 7).

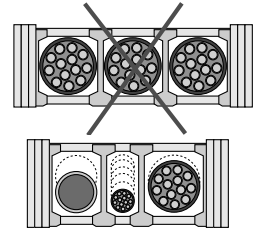

Figure 7

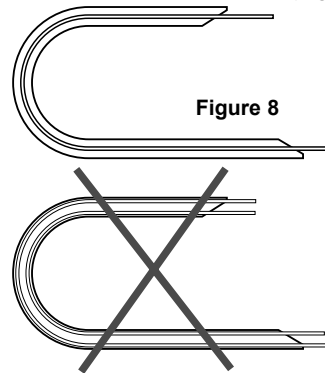

Figure 8

4. Cables/hoses should be installed along the centerline of the carriers (Fig. 8). This eliminates undue cable/hose wear caused by excessive contact on the inner or outer radius of the chain. Be sure cables/hoses are not under tension or installed with too much slack.

5. Allow extra space in the compartment for high pressure hoses. Depending on type of construction, some hoses will increase in length under pressure while others will shrink. Check hose manufacturer to ascertain how much shrinkage or lengthening will occur.

6. Clamp all cables/hoses firmly at both ends of the chain (Fig. 9). To avoid damage to the inner structure of the cables/hoses, clamp over a wide area of the outer jacket. Always leave slack between clamps and termination points to avoid stress on cables/hoses.

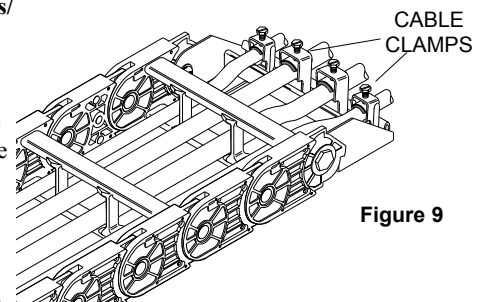

Figure 9

7. Test run PowerTrak chain at slow speed to make sure there is no pinching and that no kinks have developed in hoses or cables. Perform test with hoses at operating pressure. Re-adjust cable/hose length if required.



Gleason Reel Corp.
600 S. Clark St.
Mayville, WI 53050
Phone 920-387-4120 • FAX 920-387-4189
www.hubbell-gleason.com