

INSTALLATION and MAINTENANCE INSTRUCTIONS

SM21 GEAR DRIVE ELECTRIC CABLE REELS

All units are provided with right hand rotation unless otherwise specified. This means that cable is pulled off spool top left or bottom right (spool rotates clockwise to wind cable) **when viewing spring end of reel**. See diagram on parts page.

Clock-type springs provide power for automatic cable take-up. **Spring must be pretensioned at time of installation** to ensure that tension is applied to cable at all times. A tension adjustment ratchet wrench is provided with each reel.

⚠ WARNING

Do not attempt to relieve spring tension using spanner wrench. Doing so may result in personal injury.

INSTALLATION

1. Ensure that machinery to be serviced by reel is at position closest to reel.
2. Securely mount reel in desired position using 1/2"(M12) bolts. Be sure spool is aligned with cable run.
3. Position optional cable guide, if reel is so equipped. See CABLE INSTALLATION DRAWING
4. Connect free end of cable to junction box on machine or adjust cable stop so that desired length of cable extends from reel.
5. Remove ratchet wrench and cover plate on spring housing to expose shaft and spring hub. (See Figure 1).
6. Reinstall ratchet wrench (Fig 2). Use long handled wrench to rotate arbor driver clockwise (for standard rotation). Number of 360° turns should match last digit in model number on serial plate. *If model number includes an "R", reel is reverse rotation and wrench must be rotated counterclockwise.* (See EXPLANATION on parts list page.)

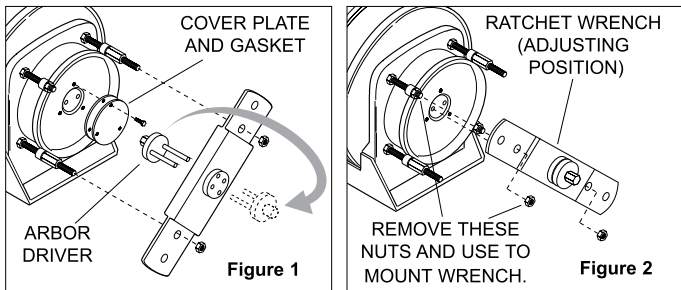

⚠ CAUTION

Do not exceed number of turns indicated on serial plate. Over-tensioning can cause a broken spring, sheared shaft or other damage.

NOTE: On reels containing more than one spring, the hubs are connected at the factory. Therefore, by tightening the outer spring, the inside spring(s) will be tightened.

7. Remove wrench and install on other spring stack. Add pretension turns as in step 6, above. Springs on both sides must be adjusted equally. Remove wrench, replace cover plates and return wrench to stored position.
8. Remove collector cover and connect individual supply conductors to collector terminals. See ELECTRICAL CONNECTIONS diagram, on parts page.

MAINTENANCE

Periodically: A. Use compressed air to clean collector assembly and inside of collector housing. Inspect collector assembly for brush wear and pitted slip rings.

B. Inspect cable for wear and check mounting bolts and other hardware for tightness.

C. Check for broken springs by pulling about 2/3 cable off reel and observing "Broken Spring Indicators" on sides of spring canisters. See Fig. 3.

NOTE: Bearings and springs are prelubricated and require no periodic maintenance.

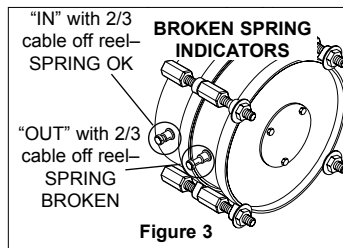

⚠ WARNING

Do not attempt to remove spring from its housing. Clock-type springs can be dangerous to handle. Removal of spring from housing could result in personal injury.

SPRING REPLACEMENT

The unique SAFETYCHANGE® spring motor consists of a spring and hub sealed within a housing. A replacement spring is supplied sealed in its housing and the old unit should be discarded completely.

1. Turn off all electric power.
2. Disconnect cable from machine junction box.
3. Relieve all spring tension following steps under **SPRING DETENSIONING** on last page.
4. Remove inspection cover from face of spring housing.
5. Rotate spool clockwise and observe spring shaft. Shaft should rotate clockwise and hub (with spring attached) should remain stationary.

NOTE: Do not attempt to remove spring if resistance is met or hub tends to rotate with shaft.

Continue to rotate spool and strike end of shaft several sharp blows with a lead hammer or rubber mallet until shaft rotates freely and hub remains stationary.

6. Remove (4) nuts which secure spring motor(s) to frame.
7. Slide spring motor(s) off shaft and discard.
8. Install replacement spring motor(s), pawls and pawl springs.

NOTE: Pawl springs must be located between the pawls and the deepest section of the shaft grooves. Make sure that pawls and pawl springs are inserted flush with ends of shaft and hub or they may rub against inspection cover.

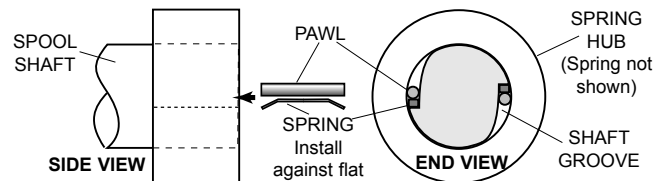

9. Tighten nuts (and extension bolts) securing spring housing(s) to reel frame.
10. Connect free end of cable to junction box or adjust cord stop.
11. Retighten nut on spring detensioner. See **SPRING DETENSIONING**, back page.
12. Tension spring with spanner wrench. Refer to **INSTALLATION** section
13. Replace inspection cover and top gear access cover.

ILLUSTRATED PARTS LIST

SM-21 GEAR DRIVE ELECTRIC CABLE REELS manufactured after April 16, 2001

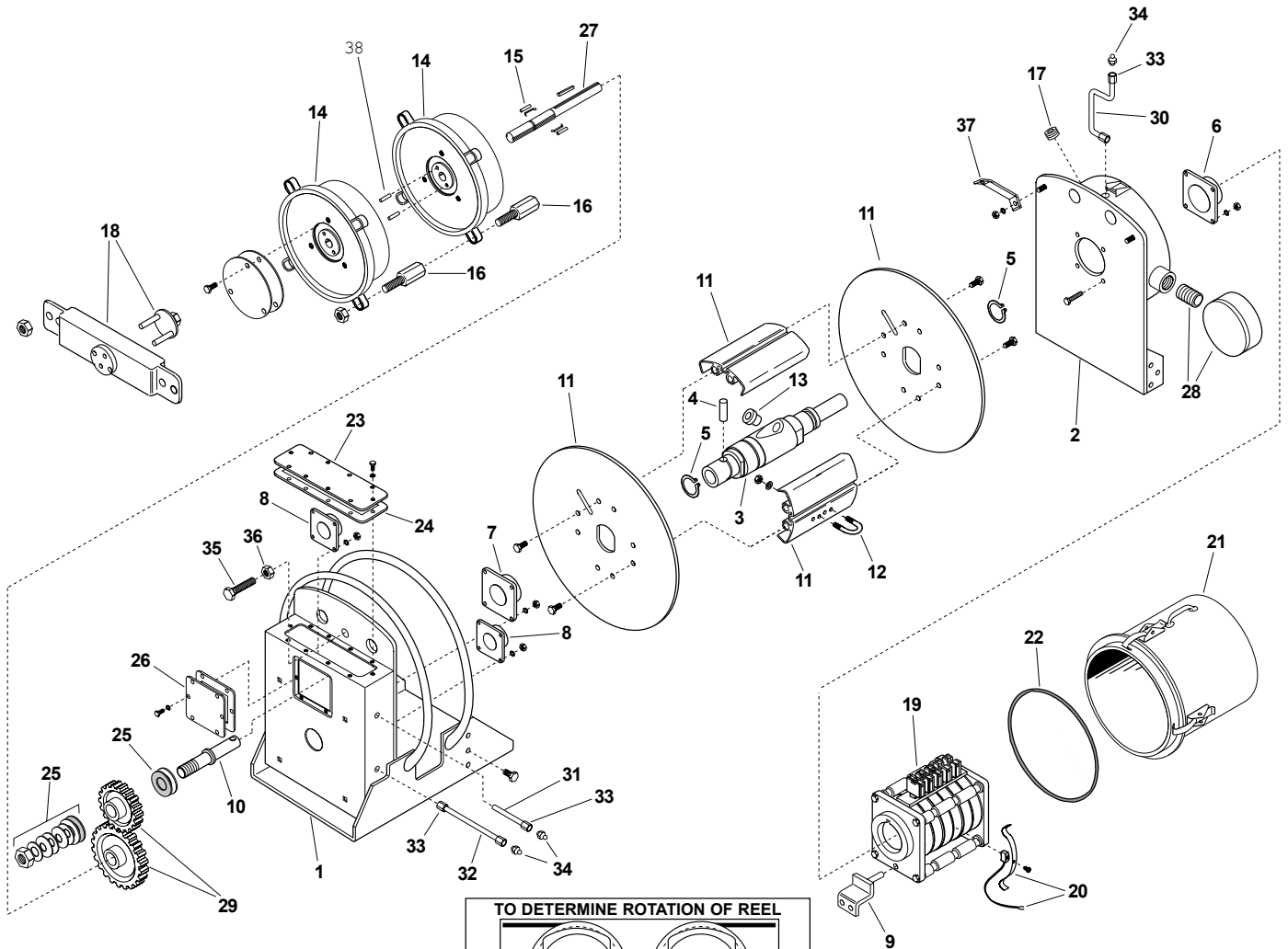

Always specify **SERIAL NUMBER & MODEL NUMBER** when ordering parts.

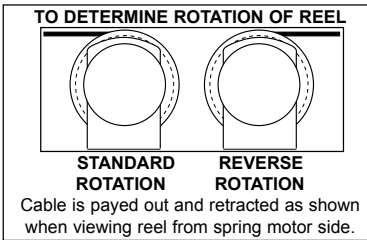

ELECTRICAL CONNECTIONS

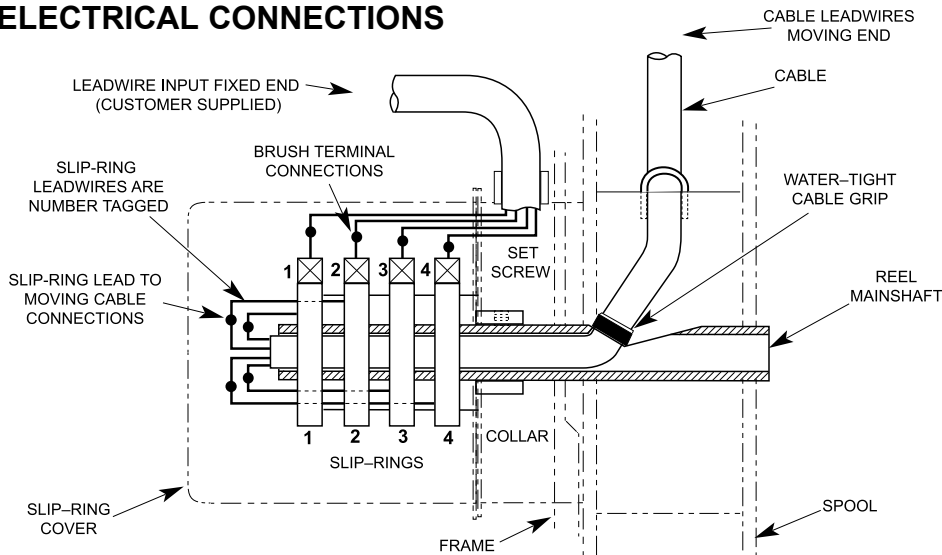

NOTE:
Wire size, wire connectors, connection sequence, and connection methods must comply with National Electrical code and Local Electrical ordinances. If in doubt, contact a local electrical contractor or electrical inspector.

COLOR SEQUENCE FOR TYPE SO CABLE

- THREE CONDUCTOR CABLE**
 # 1 - BLACK
 # 2 - WHITE
 # 3 - GREEN (ground)
- FOUR THRU TWELVE CONDUCTOR CABLE**
 # 1 - BLACK
 # 2 - WHITE
 # 3 - RED
 # 4 - GREEN (ground)
 # 5 - ORANGE
 # 6 - BLUE
 # 7 - WHITE W/ BLACK TRACER
 # 8 - RED W/ BLACK TRACER
 # 9 - GREEN W/ BLACK TRACER
 # 10 - ORANGE W/ BLACK TRACER
 # 11 - BLUE W/ BLACK TRACER
 # 12 - BLACK W/ WHITE TRACER

SLIP-RING ENCLOSURE

- 600 VOLT AC. 250 VOLT DC. WATERTIGHT, DUST TIGHT.
- DO NOT EXCEED AMPERAGE RATING OF CABLE OR SLIP RING.
- NUMBER OF CIRCUITS MAY VARY FROM TWO (MINIMUM) TO 36 (MAXIMUM). FOUR CIRCUITS SHOWN.

SM-21 GEAR DRIVE ELECTRIC CABLE REEL REPLACEMENT PARTS LIST

For SM-21 Gear Drive Electric Cable Reels manufactured after April 16, 2001

NOTE: Applicable mounting hardware included with each kit.

ITEM	KIT NO.	DESCRIPTION	QTY.
1	015899	Main Frame and Gear Case Assembly	1
2	015920	Vertical Frame	1
3	047565	Main Shaft	1
4	012137	Drive Pin	1
5	118322	Retaining Ring	2
6	016516	Bearing Kit - 2" Bore (Includes mounting hardware)	1
7	016517	Bearing Kit - 1.75" Bore (Includes mounting hardware)	1
8	016518	Bearing Kit - 1.25" Bore (Includes mounting hardware)	2
9	016519	Drive Stud Bracket Kit	1
10	015944	Stub Shaft, Drum Gear	1
11	04756601	Spool Assembly - 8" Dia. Wrapper (Includes two spool disks, wrapper segments & hardware)	1
11	04756602	Spool Assembly - 9" Dia. Wrapper	1
11	04756603	Spool Assembly - 10" Dia. Wrapper	1
11	04756604	Spool Assembly - 11" Dia. Wrapper	1
11	04756605	Spool Assembly - 12" Dia. Wrapper	1
11	04756606	Spool Assembly - 13" Dia. Wrapper	1
11	04756607	Spool Assembly - 14" Dia. Wrapper	1
11	04756608	Spool Assembly - 15" Dia. Wrapper	1
11	04756609	Spool Assembly - 16" Dia. Wrapper	1
11	04756610	Spool Assembly - 17" Dia. Wrapper	1
12	012444	Cable Clamp Kit, 0.38-0.74 Dia. Cable (U-bolt with lockwashers and hex nuts)	1
12	012445	Cable Clamp Kit, 0.75-1.11 Dia. Cable	1
12	012446	Cable Clamp Kit, 1.12-1.50 Dia. Cable	1
13	012459	Cable Connector, 0.38-0.50 Dia. Cable	1
13	012460	Cable Connector, 0.50-0.62 Dia. Cable	1
13	012461	Cable Connector, 0.62-0.75 Dia. Cable	1
13	012462	Cable Connector, 0.75-0.88 Dia. Cable	1
13	012463	Cable Connector, 0.88-1.00 Dia. Cable	1
13	012464	Cable Connector, 1.00-1.12 Dia. Cable	1
13	012465	Cable Connector, 1.12-1.25 Dia. Cable	1
13	012466	Cable Connector, 1.25-1.38 Dia. Cable	1
13	012467	Cable Connector, 1.38-1.50 Dia. Cable	1
14	016520	Spring Motor Kit, Standard Rotation-100 (Includes snap ring, two pawls, two springs, hub cover, and gasket)	AR
14	016521	Spring Motor Kit, Reverse Rotation-100	AR
15	012427	Pawl Kit - 100 Spring (Includes two pawls & two springs)	1
16	016522	Spring Mounting Kit (Includes four extension studs)	1
17	106873	Collector Drive Access Plug	1
18	032804	Ratchet Spring Adjustment Wrench	1

NOTE: Please consult factory for optional accessories, roller guides, ratchet lock and limit switch.

ITEM	KIT NO.	DESCRIPTION	QTY.
19	012285	Collector Assembly, 2 Pole, 35 Amp	1
19	012286	Collector Assembly, 3 Pole, 35 Amp	1
19	012287	Collector Assembly, 4 Pole, 35 Amp	1
19	012288	Collector Assembly, 6 Pole, 35 Amp	1
19	012289	Collector Assembly, 8 Pole, 35 Amp	1
19	012290	Collector Assembly, 10 Pole, 35 Amp	1
19	012291	Collector Assembly, 12 Pole, 35 Amp	1
19	012292	Collector Assembly, 14 Pole, 35 Amp	1
19	012293	Collector Assembly, 16 Pole, 35 Amp	1
19	012298	Collector Assembly, 2 Pole, 75 Amp	1
19	012299	Collector Assembly, 3 Pole, 75 Amp	1
19	012300	Collector Assembly, 4 Pole, 75 Amp	1
19	037194	Collector Assembly, 2 Pole, 125 Amp	1
19	037294	Collector Assembly, 3 Pole, 125 Amp	1
19	037295	Collector Assembly, 4 Pole, 125 Amp	1
19	013756	Collector Assembly, 2 Pole, 200 Amp	1
19	016197	Collector Assembly, 3 Pole, 200 Amp	1
19	013757	Collector Assembly, 4 Pole, 200 Amp	1
20	012440	Brush Kit (35 Amp) (Each kit includes 4 brushes, and 4 fingers)	AR
20	012441	Brush Kit (75 Amp)	AR
20	012443	Brush Kit (125 Amp / 200 Amp)	AR
21	03742101	Collector Cover Kit (9.75" long) (Includes seal ring)	1
21	03742102	Collector Cover Kit (12.75" long)	1
21	03742103	Collector Cover Kit (14.75" long)	1
21	03742104	Collector Cover Kit (19.25" long)	1
22	016213	Seal Ring (only)	1
23	015936	Gear Detensioner Cover	1
24	015937	Gear Detensioner Cover Gasket	1
25	016525	Gear Detensioner Cover Kit (Includes washers, pads and nut)	1
26	016527	Gear Access Cover Kit (Includes cover and gasket)	1
27	015945	Spring Shaft, Gear, Std. Rot. (1001)	1
27	01594501	Spring Shaft, Gear, Rev. Rot. (1001)	1
27	015946	Spring Shaft, Gear, Std. Rot. (1002)	1
27	01594601	Spring Shaft, Gear, Rev. Rot. (1002)	1
27	015947	Spring Shaft, Gear, Std. Rot. (1003)	1
27	01594701	Spring Shaft, Gear, Rev. Rot. (1003)	1
27	015948	Spring Shaft, Gear, Std. Rot. (1004)	1
27	01594801	Spring Shaft, Gear, Rev. Rot. (1004)	1
28	016529	Collector Entrance Kit (Includes wiring box, cover and gasket)	1
29	016202	Gear Kit, Ratio 'M' (Includes one drum gear, and two spring gears)	1
29	016203	Gear Kit, Ratio 'N'	1
29	016204	Gear Kit, Ratio 'P'	1
29	016205	Gear Kit, Ratio 'Q'	1
29	016206	Gear Kit, Ratio 'R'	1
29	016207	Gear Kit, Ratio 'S'	1
29	016208	Gear Kit, Ratio 'T'	1
29	016209	Gear Kit, Ratio 'V'	1
29	016210	Gear Kit, Ratio 'W'	1
29	016211	Gear Kit, Ratio 'Y'	1
30	015958	Lube Tube, 2" Bore Bearing	1
31	015957	Lube Tube, Gearbox	1
32	016234	Lube Tube, 1.25" Bore Bearing	1
33	015955	Male Connector, 1/4" Tube x 1/8 NPT	5
34	101377	Grease Fitting	3
35	047563	Hex Hd. Cap Screw, .75-10 x 4.00	1
36	101030	Hex Nut, .75-10	1
37	015925	Hoop Brace	2
38	021762	Hub Lock Pin Kit (Includes 2 pins)	1

MODEL NUMBER EXPLANATION

SPRING REEL	FRAME SERIES	SPRING SERIES	NO. OF SPRINGS	*	NO. OF POLES	AMPACITY	CORE DIAMETER	GEAR RATIO	PRETENSION TURNS
SM	21	100	4	R	- 2	20	10	- V -	1

* INDICATES REVERSE ROTATION
NO LETTER INDICATES STANDARD ROTATION

AMPACITY CODE

CODE	MAX AMPS
3	35
7	75
12	125
20	200

INSTALLATION

Use the following procedure to relieve spring tension prior to cable or spring replacement.

WARNING

DO NOT insert hands into gearbox until springs are fully detensioned. Doing so could lead to serious injury.

1. Cycle reel thru normal operating cycle and stop when maximum amount of cable is wound onto reel spool.
2. Set spool lock to prevent spool from turning.
3. Remove access cover from top of gearbox.
4. Using open end wrench, loosen large hex nut slowly to allow springs to unwind. Fully loosen nut further with wrench until springs are completely unwound.
5. Repair reel or replace springs or cable as necessary.
6. Retighten nut until definite resistance is felt and spring washers are full compressed (flat). Replace cover.

NOTE: If hex nut is not adequately tightened, spring unwinding can occur during reel operation.

7. Pretension reel. See **INSTALLATION** section, front page.

CABLE REMOVAL

Use the following procedure to remove worn or damaged cable from reel prior to installation of new cable.

CAUTION

Failure to relieve all spring tension prior to removing cable could result in damage to equipment or personal injury. Follow instructions carefully.

1. Move machine serviced by reel to a position closest to reel. Springs will still be under pre-tension at this point.
2. Turn off all electric power.
3. Using spool lock, lock spool to prevent turning.
4. Disconnect cable from machine junction box.
5. Detension springs as described above.
6. Remove cable from spool. Loosen cable clamp and water-tight connector and disconnect conductors from slip ring.

CABLE INSTALLATION

Use the following procedure to replace cable or if reel was ordered without cable. Refer to CABLE INSTALLATION REFERENCE DRAWING, below.

1. Unspool new cable from shipping spool and lay out to eliminate twist.

NOTE: This step is not essential, but will aid in winding operation of the reel and prolong cable life.

2. Feed one end of the cable through water-tight connector on the main shaft inside the spool and into the slip ring side (See drawing below).

NOTE: This may require that jacket of cable be stripped to allow conductors to pass through shaft.

3. Connect individual conductors to appropriate rings on collector using crimp fitting or similar connection method.
4. Tighten water-tight connector and cable clamp in slot on spool disk. **Do not over-tighten.**
5. Wind the cable onto the reel spool by hand rotating spool in direction it turns free of spring tension.
6. Connect free end of cable to machine junction box.
7. Pretension reel and complete reel installation as previously described.

COLLECTOR REPLACEMENT

1. Turn off all power to reel.
2. Remove collector cover and gasket.
3. Disconnect electric leads to and from collector.
4. Remove drive stud bolt from bearing housing.
5. Remove button plug from hole in side of housing. Insert long 1/8" Allen wrench through hole and loosen two set screws in collector locking collar. Set screws are at 90° to one another.

NOTE: Older reels may have lock screws which must be removed to reach set screws holding collector to shaft.

6. Slide collector off shaft.
7. Install new collector by reversing

CABLE INSTALLATION REFERENCE DRAWING

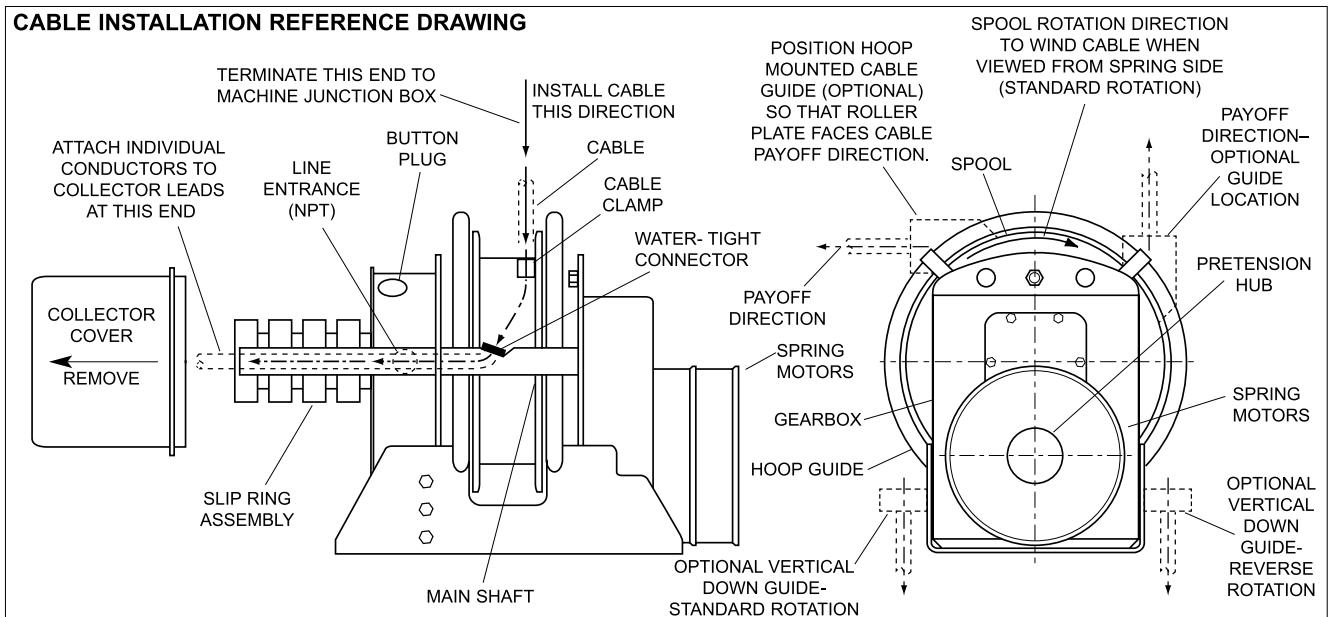

GLEASON REEL CORP.

600 South Clark St.
Mayville, WI 53050

Phone 920-387-4120 • Fax 920-387-4189