

INSTALLATION and MAINTENANCE INSTRUCTIONS

"K-18" DUAL HOSE REEL-DIRECT DRIVE

All units are provided with right hand rotation unless otherwise specified. This means that hose is pulled off spool top left or bottom right (spool rotates clockwise to wind hose) **when viewing spring end of reel**. See diagram on parts page.

Clock-type springs provide power for automatic hose take-up. **Spring must be pretensioned at time of installation** to insure that tension is applied to hose at all times. A tension adjustment spanner wrench is provided with each reel.

WARNING

If machine pull reel, move machinery to position closest to reel before adjusting spring tension. Adjusting tension with hose extended may result in damage to reel or personal injury.

INSTALLATION

1. Install hoses if reel was purchased without hoses. See instructions on page 4.
2. Insure that machinery to be serviced by reel is at position closest to reel.
3. Securely mount reel in desired position using 1/2"(M12). Be sure spool is aligned with hose run.
4. Connect free end of hoses to connections on machine.
5. Connect flexible supply lines to swivel fitting. See HOSE INSTALLATION REFERENCE DRAWING.
NOTE: Do not hard plumb to swivel fitting.
6. Remove cover plate on spring housing to expose shaft and spring hub. (See Figure 1).
7. Insert spanner wrench into holes in spring hub (Fig 2). Rotate spanner wrench counter-clockwise. Number of 360° turns should match last digit in model number on serial plate.

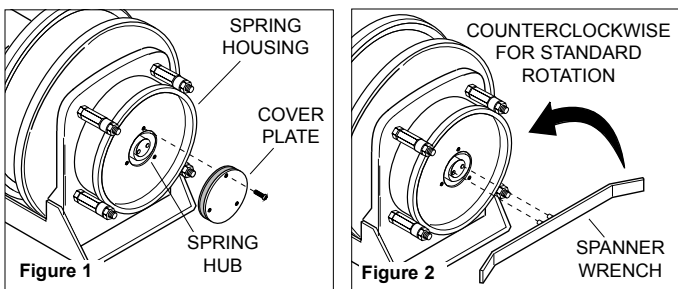

CAUTION

Do not exceed number of turns indicated on serial plate. Over-tensioning can cause a broken spring, sheared shaft or other damage.

WARNING

Do not attempt to relieve spring tension using spanner wrench. Doing so may result in personal injury.

WARNING

Some reels with large or multiple springs are equipped with a ratcheted adjustment wrench. Follow separate instructions for its use. Failure to use ratcheted wrench, on reels so equipped, could result in serious personal injury.

MAINTENANCE

Periodically:

A. Inspect hose for wear and check mounting bolts and other hardware for tightness.

B. Check for broken springs by pulling about 2/3 hose off reel and observing "Broken Spring Indicators" on sides of spring canisters (Fig. 3).

NOTE: Bearings and springs are prelubricated and require no periodic maintenance.

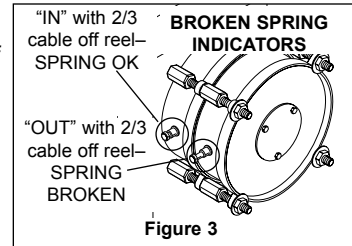

WARNING

Do not attempt to remove spring from its housing. Clock type springs can be dangerous to handle. Removal of spring from housing could result in personal injury.

SPRING REPLACEMENT

The unique SAFETYCHANGE® spring motor consists of a spring and hub sealed within a housing. A replacement spring is supplied sealed in its housing and the old unit should be discarded completely.

1. Turn off supply pressure to reel.
2. Insure that machinery to be serviced by reel is at position closest to reel. Disconnect hose from machine connections.
3. Wind all hose onto reel to relieve all spring tension.
4. Remove inspection cover from face of spring housing.
5. Rotate spool clockwise and observe inner shaft. Shaft should rotate clockwise and hub (with spring attached) should remain stationary.

NOTE: Do not attempt to remove spring if resistance is met or hub tends to rotate with shaft. Continue to rotate spool and strike end of shaft several sharp blows with a rubber mallet until shaft rotates freely and hub remains stationary.

6. Remove (4) bolts which secure spring motor to frame.
7. Slide spring motor off shaft and discard.
8. Install replacement spring motor, pawls and pawl springs.

NOTE: Pawl springs must be located between the pawls and the deepest section of the shaft grooves. Make sure that pawls and pawl springs are inserted flush with ends of shaft and hub or they may rub against inspection cover. See Fig 4, page 4.

9. Tighten bolts securing spring housing to reel frame.

DIRECT DRIVE "K-18" DUAL HOSE REEL

REPLACEMENT PARTS LIST

ITEM	KIT NO.	DESCRIPTION	QTY.
1	015521	Frame Assembly (-4 hose code)* Kit <i>(Includes frame and swivel bracket)</i>	1
1	015522	Frame Assembly (-6 hose code)* Kit	1
1	015523	Frame Assembly (-8 hose code)* Kit	1
2	015535	Spool Discs-18" (Set of two)	1
3	015539	Main Shaft Kit (-4 hose code)* <i>(Includes shaft, center tube, retaining ring and drive pin)</i>	1
3	015540	Main Shaft Kit (-6 hose code)*	1
3	015541	Main Shaft Kit (-8 hose code)*	1
4	015543	Wrapper Kit (-4 hose code)* <i>(Includes 2 covers and 4 spacers)</i>	1
4	015544	Wrapper Kit (-6 hose code)*	1
4	015545	Wrapper Kit (-8 hose code)*	1
5	015547	Bearing Kit-Swivel End <i>(Includes bearing and housing)</i>	1
6	015548	Bearing Kit-Spring End <i>(Includes bearing, housing and gasket)</i>	1
7	700079	Swivel Kit (-4 hose code)*	1
7	700080	Swivel Kit (-6 hose code)*	1
7	700081	Swivel Kit (-8 hose code)*	1
8	017190	Spanner Wrench (35-80 Springs)	1
8	017191	Spanner Wrench (100 Springs)	1
9	032805	Ratchet Wrench (35-80 springs)	1
9	032804	Ratchet Wrench (100 springs)	1
10	012425	Pawl Kit (35-60 Springs) <i>(Includes 2 pawls and springs)</i>	AR
10	012426	Pawl Kit (62-80 Springs)	AR
10	012427	Pawl Kit (100 Springs)	AR

ITEM	KIT NO.	DESCRIPTION	QTY.
11	017041	Spring Motor Kit, Std. Rot.-35 <i>(Includes pawls, pawl springs, cover, gaskets, and snap ring)</i>	AR
11	017042	Spring Motor Kit, Rev. Rot.-35	AR
11	017043	Spring Motor Kit, Std. Rot.-60	AR
11	017044	Spring Motor Kit, Rev. Rot.-60	AR
11	017045	Spring Motor Kit, Std. Rot.-62	AR
11	017046	Spring Motor Kit, Rev. Rot.-62	AR
11	017047	Spring Motor Kit, Std. Rot.-75	AR
11	017048	Spring Motor Kit, Rev. Rot.-75	AR
11	017049	Spring Motor Kit, Std. Rot.-80	AR
11	017050	Spring Motor Kit, Rev. Rot.-80	AR
11	017051	Spring Motor Kit, Std. Rot.-100	AR
11	017052	Spring Motor Kit, Rev. Rot.-100	AR
12	014200	Stub Shaft, Std. Rot. (351)**	1
12	01420001	Stub Shaft, Rev. Rot. (351)**	1
12	014202	Stub Shaft, Std. Rot. (621, 751, 801)**	1
12	01420201	Stub Shaft, Rev. Rot. (621, 751, 801)**	1
12	016306	Stub Shaft, Std. Rot. (622, 752, 801)**	1
12	01630601	Stub Shaft, Rev. Rot. (622, 752, 801)**	1
12	014204	Stub Shaft, Std. Rot. (1001)**	1
12	01420401	Stub Shaft, Rev. Rot. (1001)**	1
Replacement Seal Kits (-4, -6, -8 hose code):			
13	015564	Nitrile - Hydraulic Fluid, Water, Pneumatic	1
13	015565	Propyl - Phosphate Ester Base	1
13	015566	Vitron - Pydraul 135	1
14	017054	Extension Bolts (62, 75, 80 Springs) <i>(4 bolts per kit-less hardware)</i>	AR
14	017055	Extension Bolts (100 Springs)	AR
15	016182	Carriage Bolt, .50-13 x 1.5	AR
16	021291	Lockwasher, .56 Med., Z.P.	AR
17	100959	Hex Nut, .50-13, Z.P.	AR
18	101211	Flat Washer, .50	AR
19	P06-03	ESNA Lock Nut, .50-13, Z.P.	AR
20	021762	Hub Lock Pins (100 Springs)	AR
20	021761	Hub Lock Pins (All Other Springs)	AR

* Refer to Model Number Structure on following page. Reel model number is found on serial plate affixed to reel.

**Indicates spring size and number of springs. Example: 621=one 62 size spring.

TO DETERMINE ROTATION OF REEL

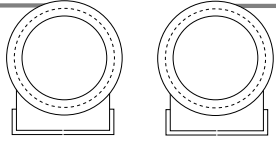

**STANDARD
ROTATION** **REVERSE
ROTATION**

Hose is played out and retracted as shown when viewing reel from spring motor side.

**Always specify
SERIAL NUMBER & MODEL NUMBER
when ordering parts.**

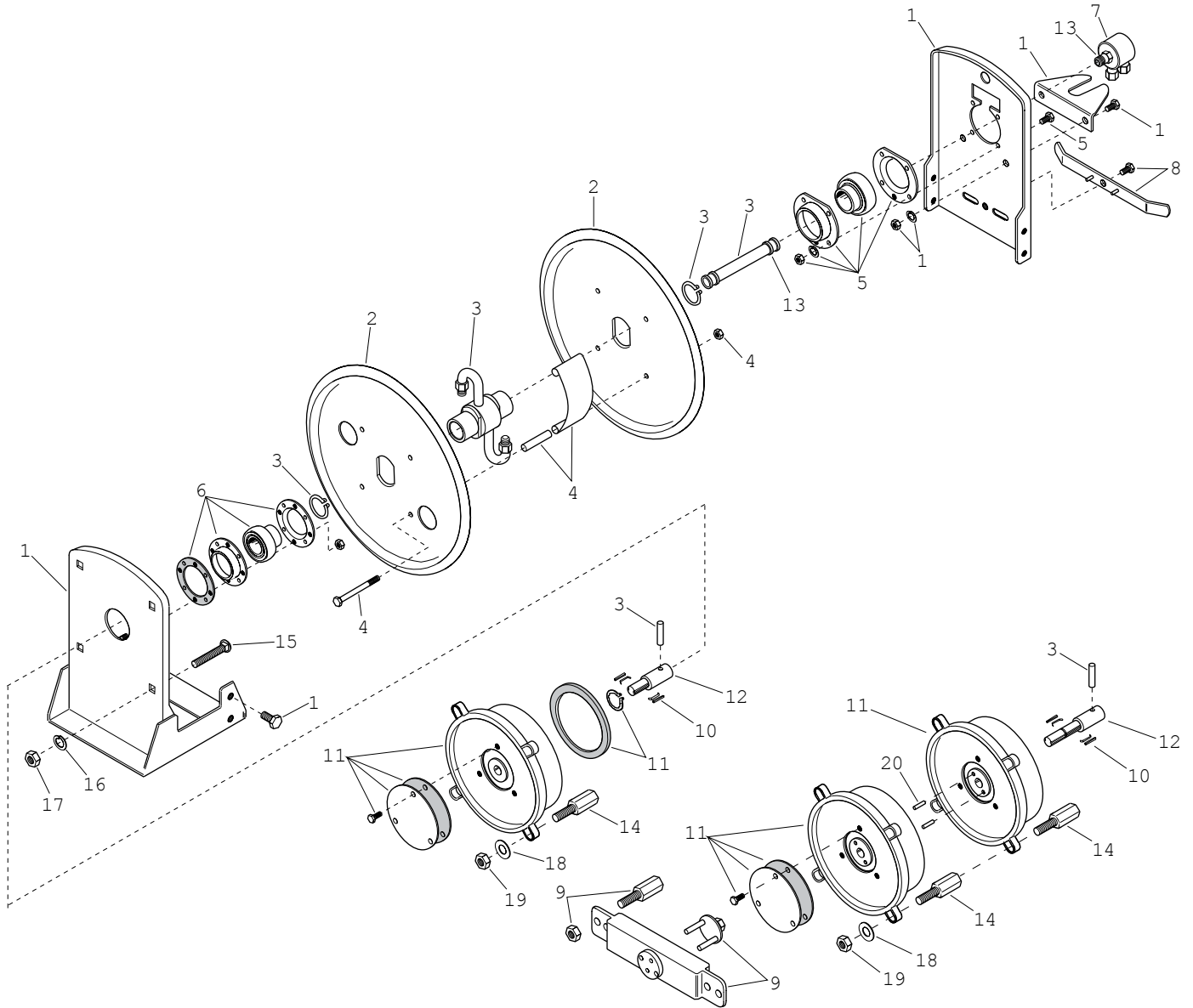

Reel Model Number Structure

K 18 75 1 - 4 - 1

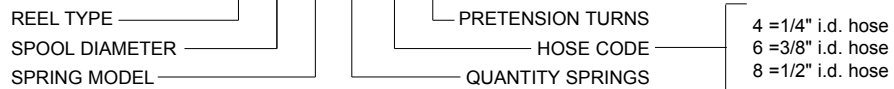

10. Connect free end of hose to connections on machine or adjust hose stop so that desired length of hose extends from reel.
11. Tension spring with spanner wrench. Refer to **INSTALLATION** section.
12. Replace inspection cover.

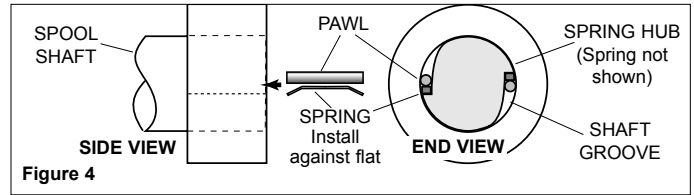

HOSE REMOVAL

Use the following procedure to remove worn or damaged hoses from reel prior to installation of new hoses.

1. Move machine serviced by reel to a position closest to reel. Spring will still be under pre-tension at this point.
2. Turn off supply pressure to reel.
3. Disconnect hoses from machine or other attachments. Remove hose stops, if installed, and allow hoses to retract onto spool. Ensure all tension is off spring by manually rotating spool (normally clockwise when viewed from spring side).
4. Unwrap hoses without allowing spool to turn.
5. Disconnect hoses from elbows inside spool wrapper.
6. Install new hoses following directions below.

HOSE INSTALLATION

Use the following procedure to replace hoses or if reel was ordered without hoses. Refer to **HOSE INSTALLATION REFERENCE DRAWING**, below.

1. Unspool new hose from shipping spool and lay out to eliminate twist.

NOTE: This step is not essential, but will aid in winding operation of the reel and prolong hose life.

2. Connect hoses to elbows inside spool wrapper. (See drawing below.)
3. Wind the hose onto the reel spool by hand rotating spool in direction it turns free of spring tension. (Normally clockwise when viewed from spring side)
4. Complete working end connections.
5. Pretension reel and complete installation as described in **REEL INSTALLATION** section.

HOSE INSTALLATION REFERENCE DRAWING

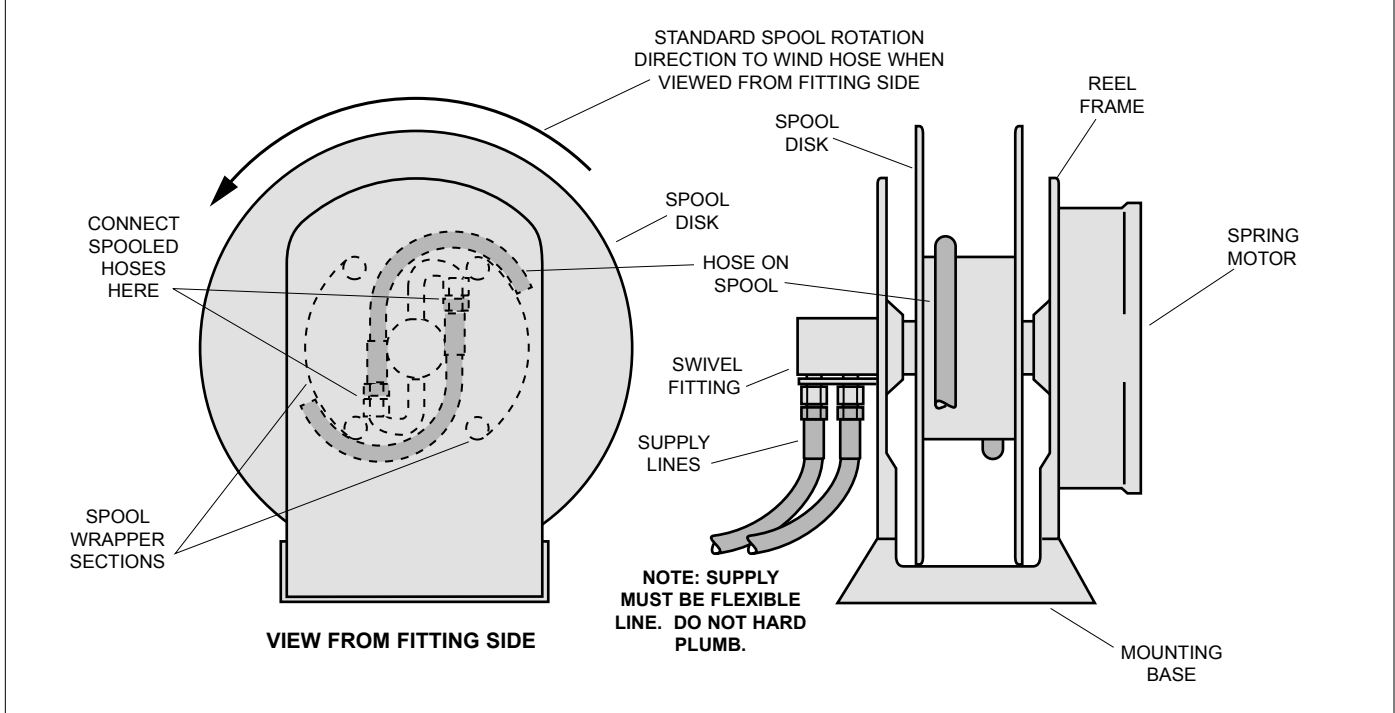

GLEASON REEL CORP.
 600 South Clark St.
 Mayville, WI 53050-0026
 Phone 920-387-4120 • Fax 920-387-4189