

INSTALLATION and MAINTENANCE INSTRUCTIONS

SHO TWIN SPRING STACK ELECTRIC CABLE REELS

All units are provided with right hand rotation unless otherwise specified. This means that cable is pulled off spool top left or bottom right (spool rotates clockwise to wind cable) **when viewing spring end of reel**. See diagram on parts page.

Clock-type springs provide power for automatic cable take-up. **Spring must be pretensioned at time of installation** to insure that tension is applied to cable at all times. A tension adjustment spanner wrench is provided with each reel.

⚠ WARNING

Some reels with large or multiple springs are equipped with a ratcheted adjustment wrench. Follow separate instructions for its use. Failure to use ratcheted wrench, on reels so equipped, could result in serious personal injury.

⚠ WARNING

Do not attempt to relieve spring tension using spanner wrench. Doing so may result in personal injury.

INSTALLATION

1. Insure that machinery to be serviced by reel is at position closest to reel.
2. Securely mount reel in desired position using 3/8"(M10) bolts. Be sure spool is aligned with cable run.
3. Position optional cable guide, if reel is so equipped.
4. Connect free end of cable to junction box on machine or adjust cable stop so that desired length of cable extends from reel.
5. Remove cover plate on spring housing to expose shaft and spring hub. (See Figure 1).
6. Insert spanner wrench into holes in spring hub (Fig 2). Rotate wrench counterclockwise (for standard rotation). Number of 360° turns should match last digit in model number on serial plate. *If model number includes an "R", reel is reverse rotation and wrench must be rotated clockwise.* (See EXPLANATION on parts list page.)

NOTE: If reel is equipped with ratcheted adjustment wrench, follow instructions on separate sheet.

NOTE: On reels containing more than one spring, the hubs are connected at the factory. Therefore, by tightening the outer spring, the inside spring(s) will be tightened.

7. Remove collector cover and connect individual supply conductors to collector terminals.

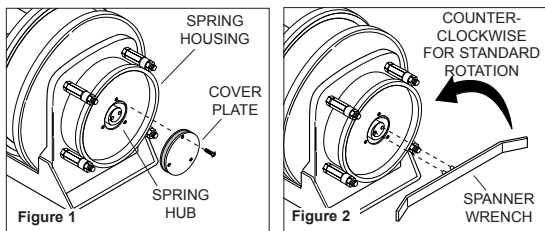

⚠ WARNING

Equal number of the specified pre-tension turns must be applied to **both** spring stacks.

⚠ CAUTION

Do not exceed number of turns indicated on serial plate. Over-tensioning can cause a broken spring, sheared shaft or other damage.

MAINTENANCE

Periodically: A. Use compressed air to clean collector assembly and inside of collector housing. Inspect collector assembly for brush wear and pitted slip rings.

B. Inspect cable for wear and check mounting bolts and other hardware for tightness.

C. Check for broken springs by pulling about 2/3 cable off reel and observing "Broken Spring Indicators" on sides of spring canisters. See Fig. 3.

NOTE: Bearings and springs are prelubricated and require no periodic maintenance.

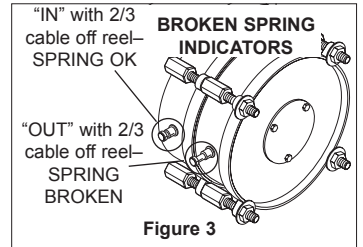

⚠ WARNING

Do not attempt to remove spring from its housing. Clock-type springs can be dangerous to handle. Removal of spring from housing could result in personal injury.

SPRING REPLACEMENT

The unique SAFETYCHANGE® spring motor consists of a spring and hub sealed within a housing. A replacement spring is supplied sealed in its housing and the old unit should be discarded completely.

1. Turn off all electric power.
2. Disconnect cable from machine junction box.
3. Wind all cable onto reel to relieve all spring tension.
4. Remove inspection cover from face of spring housing.
5. Rotate spool clockwise and observe inner shaft. Shaft should rotate clockwise and hub (with spring attached) should remain stationary.

NOTE: Do not attempt to remove spring if resistance is met or hub tends to rotate with shaft.

Continue to rotate spool and strike end of shaft several sharp blows with a lead hammer or rubber mallet until shaft rotates freely and hub remains stationary.

6. Remove (4) nuts which secure spring motor(s) to frame.
7. Slide spring motor(s) off shaft and discard.

NOTE: On multi-spring reels, be sure to remove and **save** dowel pins which connect one spring hub with another. Also remove snap rings on shaft between spring housings.

8. Install replacement spring motor(s), pawls and pawl springs.

NOTE: Pawl springs must be located between the pawls and the deepest section of the shaft grooves. Make sure that pawls and pawl springs are inserted flush with ends of shaft and hub or they may rub against inspection cover.

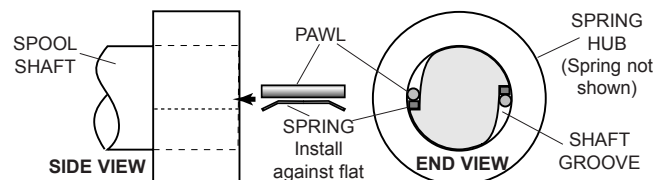

9. Tighten nuts (and extension bolts) securing spring housing(s) to reel frame.
10. Connect free end of cable to junction box on machine or adjust cord stop so that desired length of cord extends from reel.
11. Tension spring with spanner wrench. Refer to **INSTALLATION** section.
12. Replace inspection cover.

CONTINUED ON BACK PAGE

ILLUSTRATED PARTS LIST

SHO TWIN SPRING ELECTRIC CABLE REELS

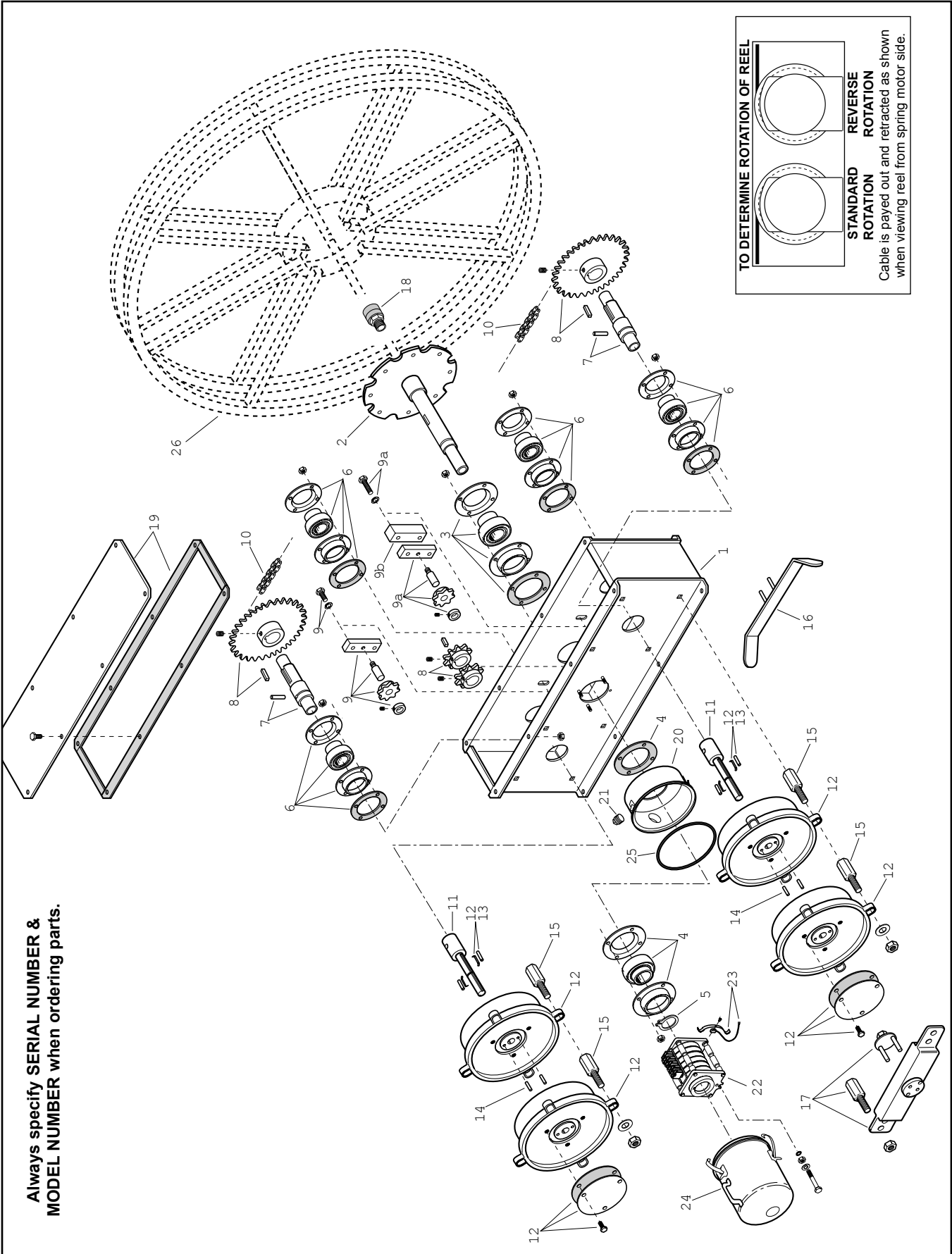

Always specify SERIAL NUMBER & MODEL NUMBER when ordering parts.

TO DETERMINE ROTATION OF REEL

	STANDARD ROTATION
	REVERSE ROTATION

Cable is payed out and retracted as shown when viewing reel from spring motor side.

SHO TWIN SPRING ELECTRIC CABLE REEL REPLACEMENT PARTS LIST

NOTE: Applicable mounting hardware included with each kit.

ITEM	KIT NO.	DESCRIPTION	QTY.
1	020554	Frame Assembly-SHO	1
2	027853	Collector Shaft - 14-17" Dia. Spool Wrapper	1
2	027854	Collector Shaft - 18" & Over Dia. Spool Wrapper	1
3	021752	Bearing Kit-2" bore (Includes housing and gasket)	1
4	012402	Bearing Kit-2" Bore (Includes housing and gasket)	1
5	105060	Retaining Ring	1
6	012401	Bearing Kit-1.75" Bore (Includes housing and gasket)	2
7	021753	Spring Shaft Kit (Includes spring shaft, stub shaft drive pin, retaining ring)	1
8	021754	Sprocket Kit, Ratio AA (Includes two sprockets and keys)	1
8	021755	Sprocket Kit, Ratio AB	1
8	021756	Sprocket Kit, Ratio AC	1
8	021757	Sprocket Kit, Ratio AD	1
8	021758	Sprocket Kit, Ratio AE	1
9	021759	Idler Kit (Includes sprocket, shaft, tensioner bar, locking collar and mounting hardware)	1
10	021760	Roller Chain Kit (Includes connecting link)	1
11	012209	Stub Shaft, Std. Rot. (801)	1
11	01220901	Stub Shaft, Rev. Rot. (801)	1
11	012210	Stub Shaft, Std. Rot. (802)	1
11	01221001	Stub Shaft, Rev. Rot. (802)	1
11	012211	Stub Shaft, Std. Rot. (803)	1
11	01221101	Stub Shaft, Rev. Rot. (803)	1
11	012212	Stub Shaft, Std. Rot. (804)	1
11	01221201	Stub Shaft, Rev. Rot. (804)	1
11	012213	Stub Shaft, Std. Rot. (1001)	1
11	01221301	Stub Shaft, Rev. Rot. (1001)	1
11	012214	Stub Shaft, Std. Rot. (1002)	1
11	01221401	Stub Shaft, Rev. Rot. (1002)	1
11	012371	Stub Shaft, Std. Rot. (1003)	1
11	01237101	Stub Shaft, Rev. Rot. (1003)	1
11	014619	Stub Shaft, Std. Rot. (1004)	1
11	01461901	Stub Shaft, Rev. Rot. (1004)	1
12	017049	Spring Motor Kit, Std. Rot. -80 (Includes one spring assembly, snap ring, pawl, pawl spring, hub cover and gasket)	AR
12	017050	Spring Motor Kit, Rev. Rot. -80	AR
12	017051	Spring Motor Kit, Std. Rot. -100	AR
12	017052	Spring Motor Kit, Rev. Rot. -100	AR
13	012426	Pawl Kit (80 Springs) (Includes two pawls and two pawl springs)	AR
13	012427	Pawl Kit (100 Springs)	AR
14	021761	Hub Lock Pin Kit—two pins (80 Springs)	AR
14	021762	Hub Lock Pin Kit—two pins (100 Springs)	AR
15	017054	Extension Bolts (80 Springs) (4 bolts per kit—less hardware)	AR
15	017055	Extension Bolts (100 Springs)	AR
16	G64-29	Adjustment Wrench (80 Springs)	1
16	G64-27	Adjustment Wrench (100 Springs)	1
17	032805	Ratchet Wrench (80 Springs)	1
17	032804	Ratchet Wrench (100 Springs)	1

ITEM	KIT NO.	DESCRIPTION	QTY.
18	012459	Cable Connector—.38 to .50 Dia. Cable	1
18	012460	Cable Connector—.50 to .62 Dia. Cable	1
18	012461	Cable Connector—.62 to .75 Dia. Cable	1
18	012462	Cable Connector—.75 to .88 Dia. Cable	1
18	012463	Cable Connector—.88 to 1.00 Dia. Cable	1
18	012464	Cable Connector-1.00 to 1.12 Dia. Cable	1
18	012465	Cable Connector-1.12 to 1.25 Dia. Cable	1
18	012466	Cable Connector-1.25 to 1.38 Dia. Cable	1
18	012467	Cable Connector-1.38 to 1.50 Dia. Cable	1
18	021764	Cable Connector-1.50 to 1.62 Dia. Cable	1
18	021765	Cable Connector-1.62 to 1.75 Dia. Cable	1
19	02176301	Chain Cover Kit (Includes cover, gasket and hardware)	1
20	045494	Collector Entrance Assembly	1
21	101652	Pipe Plug	1
22	012285	Collector Assembly, 2 Pole, 35 Amp	1
22	012286	Collector Assembly, 3 Pole, 35 Amp	1
22	012287	Collector Assembly, 4 Pole, 35 Amp	1
22	012288	Collector Assembly, 6 Pole, 35 Amp	1
22	012289	Collector Assembly, 8 Pole, 35 Amp	1
22	012290	Collector Assembly, 10 Pole, 35 Amp	1
22	012291	Collector Assembly, 12 Pole, 35 Amp	1
22	012292	Collector Assembly, 14 Pole, 35 Amp	1
22	012293	Collector Assembly, 16 Pole, 35 Amp	1
22	012294	Collector Assembly, 20 Pole, 35 Amp	1
22	012295	Collector Assembly, 24 Pole, 35 Amp	1
22	012296	Collector Assembly, 30 Pole, 35 Amp	1
22	012297	Collector Assembly, 36 Pole, 35 Amp	1
22	012298	Collector Assembly, 2 Pole, 75 Amp	1
22	012299	Collector Assembly, 3 Pole, 75 Amp	1
22	012300	Collector Assembly, 4 Pole, 75 Amp	1
22	012376	Collector Assembly, 6 Pole, 75 Amp	1
22	012377	Collector Assembly, 8 Pole, 75 Amp	1
22	037194	Collector Assembly, 2 Pole, 125 Amp	1
22	037294	Collector Assembly, 3 Pole, 125 Amp	1
22	037295	Collector Assembly, 4 Pole, 125 Amp	1
22	012304	Collector Assembly, 2 Pole, 200 Amp	1
22	012381	Collector Assembly, 3 Pole, 200 Amp	1
22	012382	Collector Assembly, 4 Pole, 200 Amp	1
22	012383	Collector Assembly, 6 Pole, 200 Amp	1
22	012384	Collector Assembly, 8 Pole, 200 Amp	1
23	012440	Brush Kit (35 Amp) (Each kit includes 4 brushes and 4 fingers)	AR
23	012441	Brush Kit (75 Amp)	AR
23	012443	Brush Kit (125 Amp/200 Amp)	AR
24	03742101	Collector Cover Kit (9.75" long) (Includes Seal Ring)	1
24	03742102	Collector Cover Kit (12.75" long)	1
24	03742103	Collector Cover Kit (14.75" long)	1
24	03742104	Collector Cover Kit (19.25" long)	1
24	03742105	Collector Cover Kit (23.75" long)	1
24	03742106	Collector Cover Kit (7.00" long)	1
25	016213	Seal Ring (only)	1
26	*	Spool Assembly	1

* Consult factory for part number of Spool Assembly and related hardware. Please give model number and serial number to obtain correct Spool Assembly.

MODEL NUMBER EXPLANATION

(Typical Model Number)

SHO 100 7 - 4 12 - XX XX XX - AE - 1

REEL TYPE	SPRING MOTOR	NUMBER SPRINGS	NUMBER POLES	AMPACITY CODE*	SPOOL DIMENSIONS and TYPE	CHAIN RATIO CODE**	PRETENSION CODES
-----------	--------------	----------------	--------------	----------------	---------------------------	--------------------	------------------

NOTE: SHO Twin Spring Reels have five to eight springs with a maximum of four in each stack. The sum of the two stub shafts (item 11) used on each reel equals the total number of springs. Example: An SHO1007 reel (shown above would have one 1003 and one 1004 stub shaft.

*SLIP RING AMPACITY CODE		**CHAIN RATIO CODE	
CODE	MAX AMPS	CODE	CHAIN RATIO
3	35	AE	1.0:1
7	75	AD	1.5:1
12	125	AC	2.0:1
20	200	AB	2.5:1
		AA	3.0:1

CABLE REMOVAL

Use the following procedure to remove worn or damaged cable from reel prior to installation of new cable.

! CAUTION

Failure to relieve all spring tension prior to removing cable could result in damage to equipment or personal injury. Follow instructions carefully

1. Move machine serviced by reel to a position closest to reel. Springs will still be under pre-tension at this point.
2. Turn off all electric power.
3. Lock spool to prevent turning using wither a spool lock mechanism or by tying off.
4. Disconnect cable from machine junction box.
5. Grip spool by hand and **carefully** release spool lock or tie. Slowly unwind remaining tension.
6. Again lock or tie spool to prevent rotation.
7. Remove cable from spool. Loosen U-bolt and water-tight connector and disconnect conductors from slip ring.
8. Install new cable following instruction at right.

CABLE INSTALLATION

Use the following procedure to replace cable or if reel was ordered without cable. Refer to CABLE INSTALLATION REFERENCE DRAWING, below.

1. Unspool new cable from shipping spool and lay out to eliminate twist.

NOTE: This step is not essential, but will aid in winding operation of the reel and prolong cable life.

2. Feed one end of the cable through water-tight connector on the main shaft inside the spool and into the slip ring side (see drawing below).

NOTE: This may require that jacket of cable be stripped to allow conductors to pass through shaft.

3. Connect individual conductors to appropriate rings on collector using crimp fitting or similar connection method.
4. Tighten water-tight connector and U-bolt provided on drum wrapper segments. **Do not over-tighten.**
5. Wind the cable onto the reel spool by hand rotation spool in direction it turns free of spring tension.
6. Connect free end of cable to machine junction box.
7. Pretension reel and complete installation as previously described.

COLLECTOR REPLACEMENT

1. Turn off all power to reel.
2. Remove collector cover and gasket.
3. Disconnect electric leads to and from collector.
4. Remove drive stud bolt from bearing housing.
5. Remove pipe plug from hole in side of housing. Insert long 1/8" Allen wrench through hold and loosen two set screws in collector locking collar. Set screws are at 90° to one another.

NOTE: Older reels may have lock screws which must be removed to reach set screws holding collector to shaft.

6. Slide collector off shaft.
7. Install new collector by reversing above steps.

CABLE INSTALLATION REFERENCE DRAWING

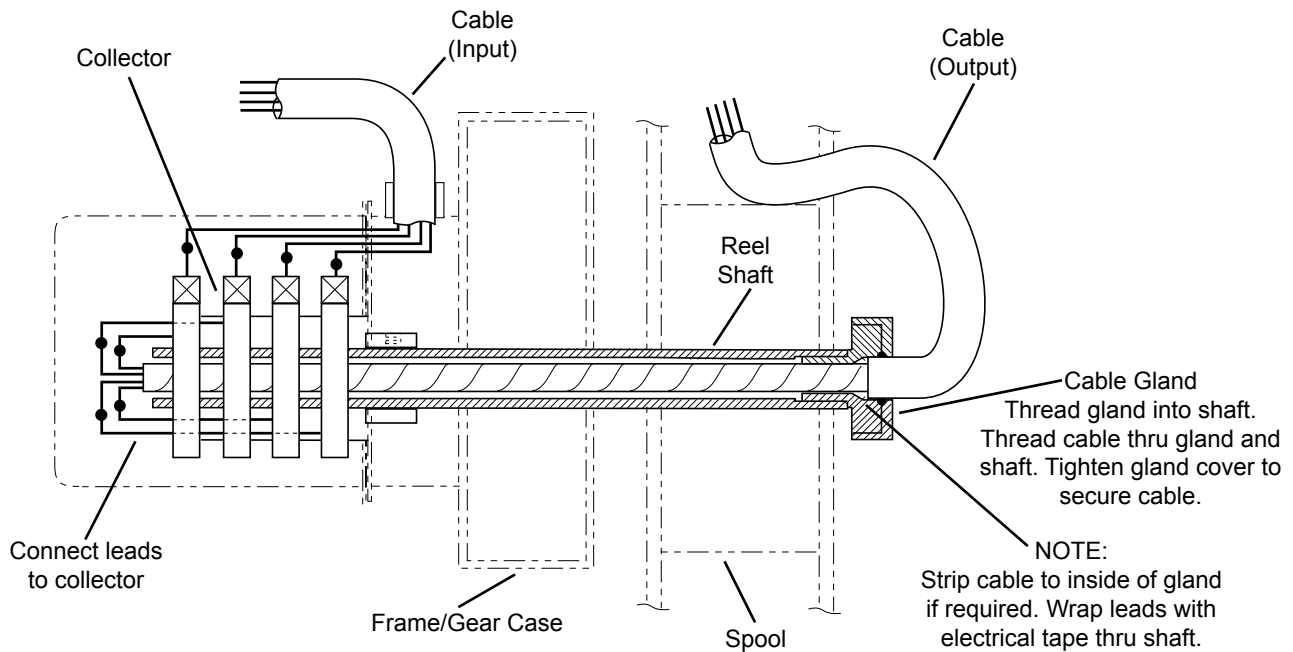

GLEASON REEL CORP.

600 South Clark St.
Mayville, WI 53050

Phone 920-387-4120 • Fax 920-387-4189