

INSTALLATION INSTRUCTIONS

250 lb. CAPACITY TOOL SUPPORT CRANE

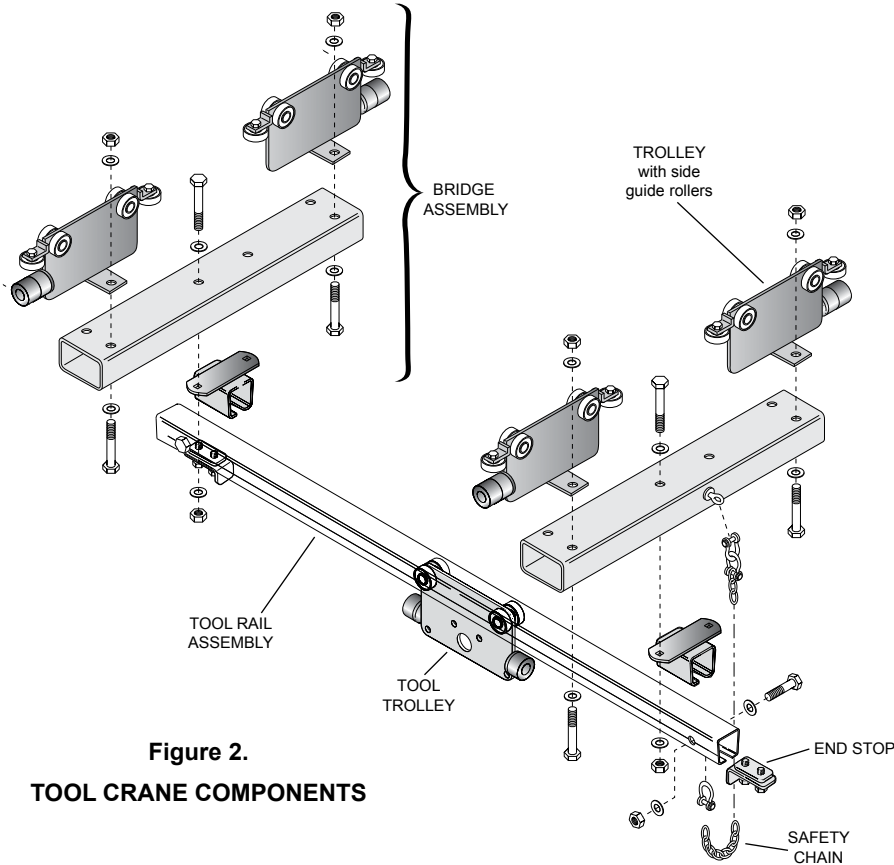

Figure 2.

TOOL CRANE COMPONENTS

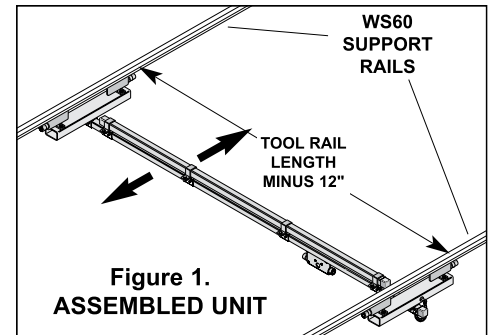
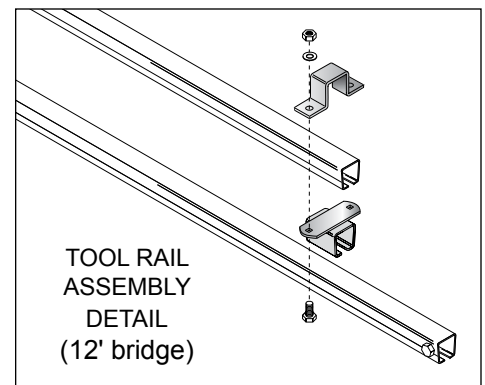

Figure 1.
ASSEMBLED UNIT



**TOOL RAIL ASSEMBLY
DETAIL
(12' bridge)**

DESCRIPTION

The OVERHEAD TOOL CRANE is ideal for situations which require tool support over a larger area than normally provided by tool rails or jib booms. The tool crane consists of three assemblies; (2) bridge truck assemblies with trolleys and hanger brackets attached, and (1) tool rail with tool trolley, end stops, end caps and stiffener on 12' bridge, Two parallel support rails (WS60 track) must be provided by the customer.

INSTALLATION

1. Check to be sure trolleys will roll freely in track that is to be used for supporting crane. Hang support rails following manufacturer's instructions. Rails must be parallel and level. Recommended center-to-center distance between rails is length of tool rail minus 12" (305 mm). See Figure 1 above. Stops must be provided at each end but stops at one end of each rail must be left out until after tool crane is installed so that trolleys can be inserted into rails.
2. Slide bridge assembly trolleys into support rails. Install stops omitted in step 1. (Figure 2)

3. Slide tool rail through hanger brackets on under side of bridge assemblies. Install safety chains. (Figure 2)
4. Adjust and align all parts until crane rolls smoothly. Tighten hanger bracket clamp bolts and check to make sure all bolts in assembly are tight. Test unit.
5. Hang balance reel and/or tool on tool trolley.

CAUTION

Maximum capacity, including tool, balancer and power hose or cord not to exceed 250 lbs. (550 kg.).

Designed for use with portable tools only.
**USE WITH POWERED OR MANUAL HOIST
NOT RECOMMENDED.**



Gleason Reel Corp.
600 South Clark Street
Mayville, WI 53050
PH: 920-387-4120
www.hubbell.com/gleasonreel/en