

INSTALLATION INSTRUCTIONS

STEEL TRACK FESTOON SYSTEM for ROUND CABLE/HOSE

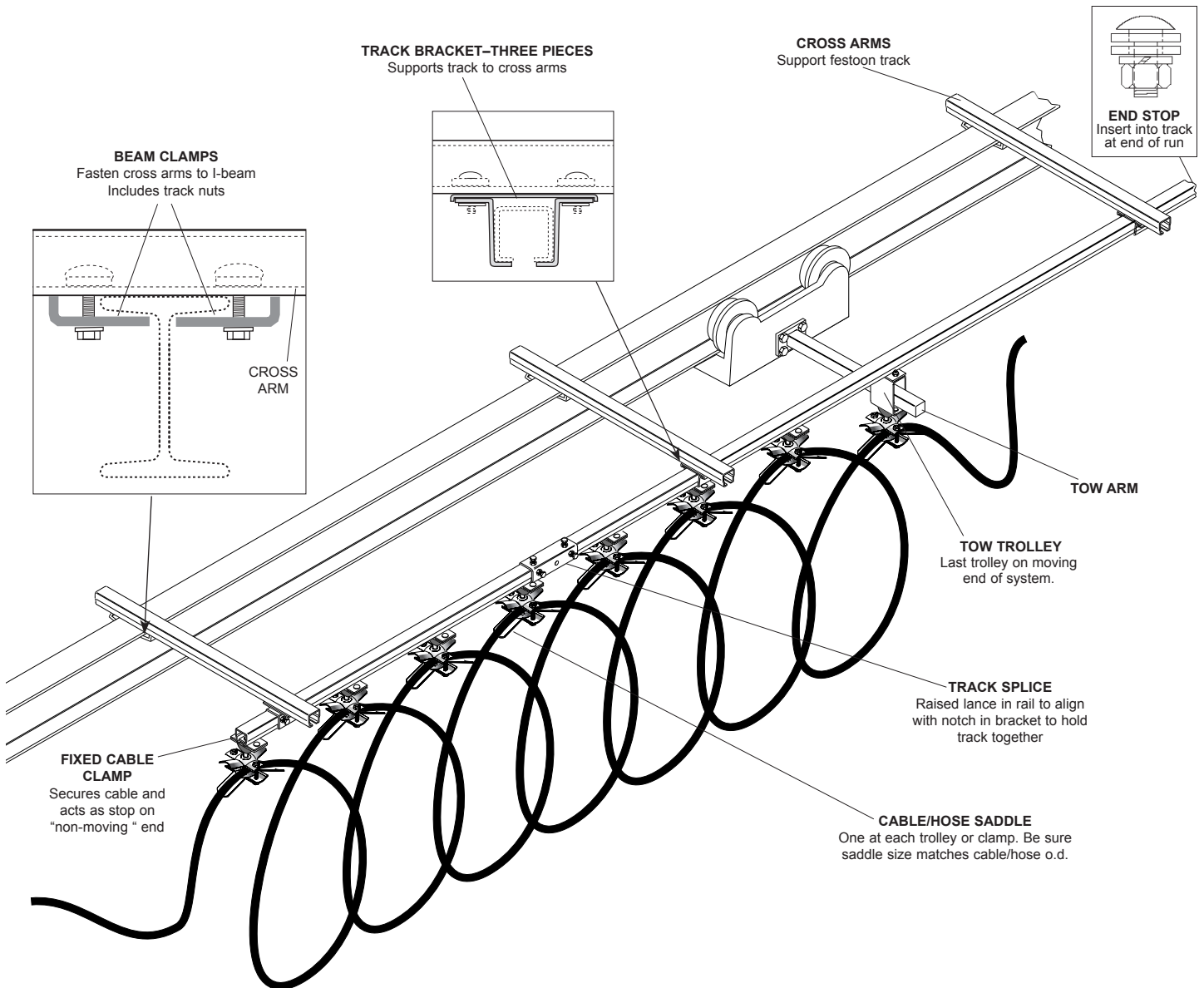

INSTALLATION

1. Clamp cross arms to supporting I-beam. Spacing between arms must not exceed 6' (1.8m) on center. Securely tighten clamps.
2. Hang festoon rail sections from bottom of arms using anchor brackets (one each end of system) and track brackets. Use track splices to join track sections. NOTE: Raised lance in track mates with notch of splice.
3. Carefully level and align track. **Festoon track must be parallel to crane track.** Shim or adjust cross arms as required. Securely tighten all set screws on anchor brackets and splice brackets.
4. Insert end stop into end of track opposite cable fixing end. Clamp tightly in place.
5. Insert tow trolley into cable fixing end of track followed by intermediate trolleys. (See illustration above).
6. Insert fixed cable clamp into track with stop angle on clamping bar facing in. Securely tighten in place.
7. Install cable or hose. Number of trolleys in kit assumes 3' loop depth (measured cable saddles to bottom of loops) when trolleys are pushed together. NOTE: Check to make sure saddles are correct size for cable/hose to be installed. See Components, over.
8. Insert tow arm through opening in tow trolley and bolt or weld tow arm to crane. Tow arm must be centered within opening and perpendicular to festoon rail.

INDIVIDUAL COMPONENTS

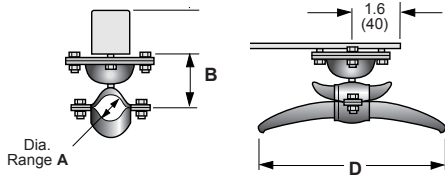

ROUND CABLE FIXED CLAMP

Catalog Number	Cable O.D. Range-A	B	D	Wgt.
C35-RE-12	0.60"-0.94"	1.40"	3.90"	2 lbs
C35-RE-13	0.95"-1.25"	1.65"	5.60"	2 lbs

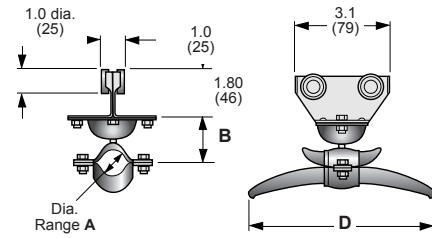

ROUND CABLE INTERMEDIATE TROLLEY

Catalog Number	Cable O.D. Range-A	B	D	Wgt.
C35-RC-12	0.60"-0.94"	1.25"	3.90"	1 lbs
C35-RC-13	0.95"-1.25"	1.50"	5.60"	1 lbs

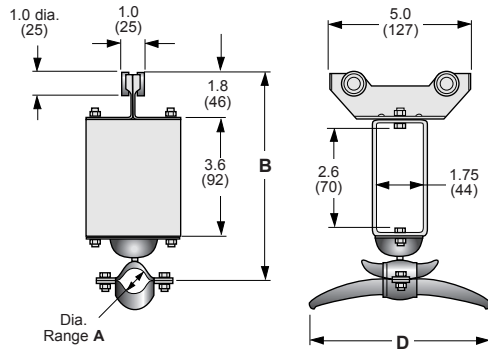

ROUND CABLE TOW TROLLEY

Catalog Number	Cable O.D. Range-A	B	D	Wgt.
C35-RT-12	0.60"-0.94"	6.70"	3.90"	3 lbs
C35-RT-13	0.95"-1.25"	6.90"	5.60"	3 lbs

TOW ARM
CTA-01
Wgt: 3.00 lbs

END STOP
C35-ES-Z
Wgt: 0.30 lbs

TRACK SPLICE
C35-TSA
Wgt: 1.00 lbs

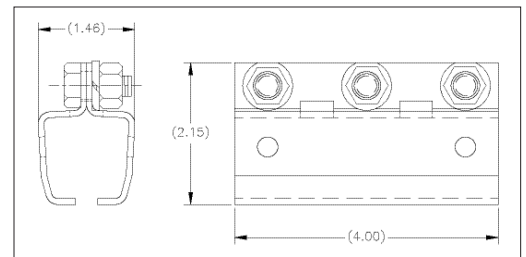
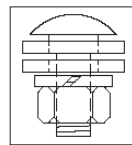
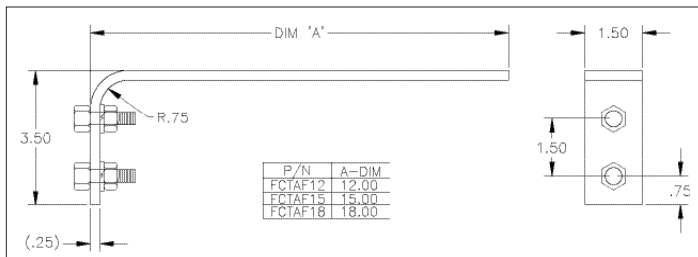

BEAM CLAMP
C35-BCA
Wgt: 0.25 lbs

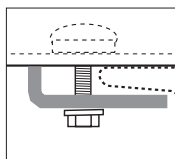

TRACK BRACKET
C35-TB
Wgt: 0.50 lbs

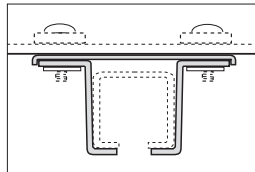

STEEL TRACK

DESCRIPTIONS	LENGTH ft	WGT. lbs	CATALOG NUMBER
Festoon Track	10'	10.50	C35-TR-10
Cross Arm	2.5'	3.00	C35-TR-2.5

Standard lengths shown. Sections may be cut to required length.

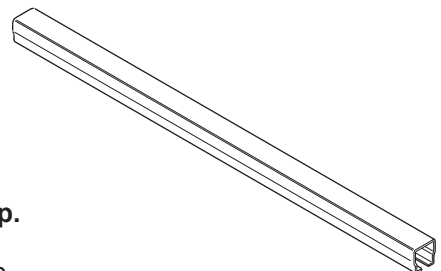

Workplace Solutions

Gleason Reel Corp.
600 S. Clark Street
Mayville, WI 53050
Phone: 920-387-4120
www.hubbell-gleason.com

Bulletin No. 630379.c