

ASSEMBLY INSTRUCTIONS

TEST BED CART

DESCRIPTION

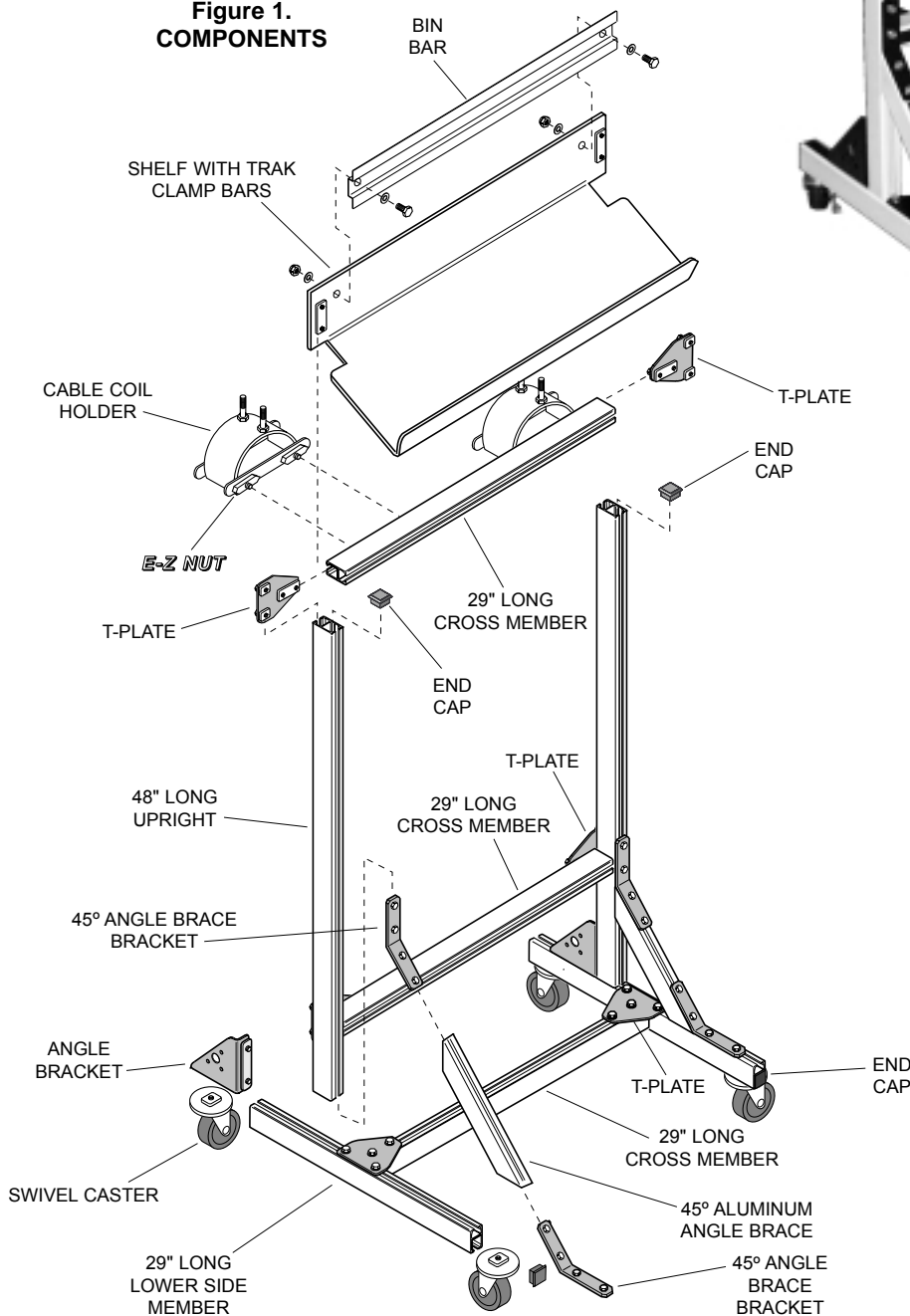
The **Test Bed Cart** allows user to assemble a customized portable test center, roll it where needed, run tests and return equipment to a protected storage area. Adjustable box mounting rails allow installation of a variety of box shapes and sizes. Included is a shelf designed to hold even the heaviest technical manuals and a rack for hanging plastic bins, the ideal place for tools. Bin boxes are not included. On the back are two coil holders for cable storage. **Maximum rated capacity, including electrical box and cables is 300 lbs.**

NOTE:

Prior to assembly, become familiar with the following instructions and names of components as shown below.

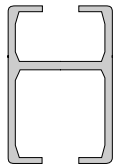


Figure 1.
COMPONENTS



IMPORTANT ASSEMBLY NOTES

1. Components are assembled using the Hubbell Workplace Solutions "ALIGN – SET – TIGHTEN" system. Brackets are clamped to aluminum extrusions with track nuts inside one of the two cavities. Always install single bolt track nuts with widest dimension perpendicular to aluminum rail.
2. All main frame members are extruded aluminum rail. Install with large cavity down.
3. Shelf, coil holders, bin bar and all brackets are steel and shipped with assembly hardware (usually track nuts) installed. Some track nuts may have to be reversed (bolt head on opposite side of plate) for proper assembly.



ASSEMBLY

1. Lay out all components. Locate shelf, bin bar, casters, and plastic end caps (Fig. 1) and set aside.
2. Locate two angle brackets and two T-plates. Place two 29" aluminum frame members on floor with large slot down. Affix angle brackets and T-plates to side members by sliding track nuts into aluminum rails. Position as shown in Figure 2, and tighten track nuts to secure.

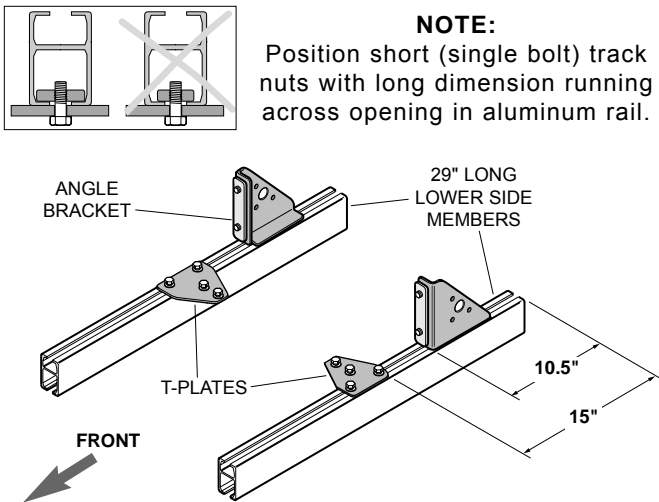


Figure 2.
ASSEMBLING LOWER SIDE MEMBERS

3. Locate two 48" long uprights and four T-plates. Affix T-plates to uprights as shown in Fig. 3. Wrench tighten to secure.

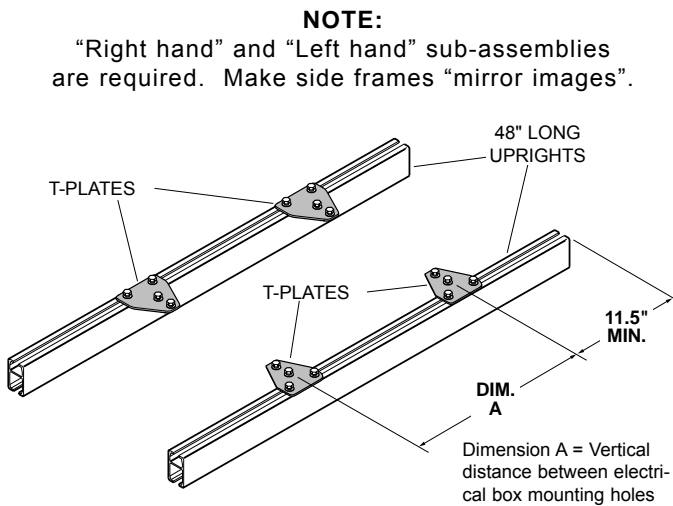


Figure 3.
ASSEMBLING FRAME UPRIGHTS

4. Assemble one upright to corresponding lower side frame assembly by sliding onto angle bracket. Tighten. Repeat for other side (Fig. 4).

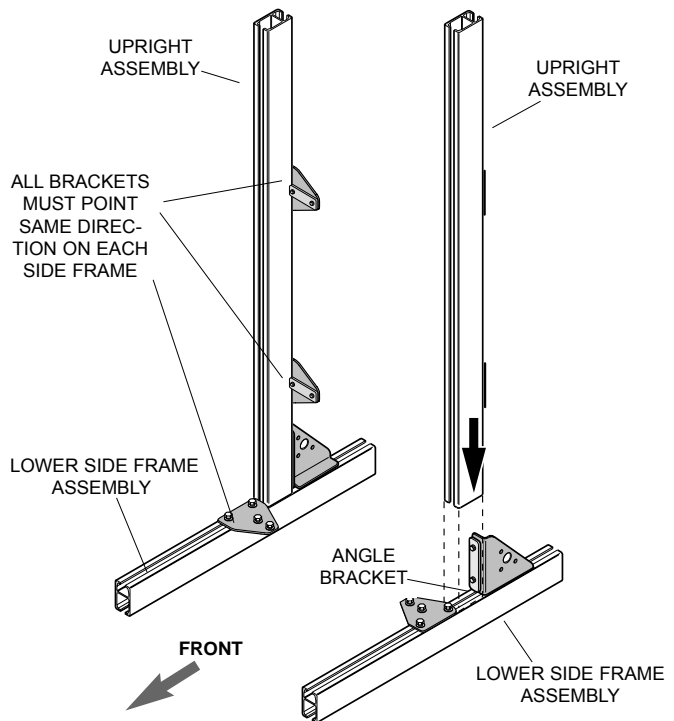


Figure 4.
ASSEMBLING UPRIGHTS TO LOWER SIDE MEMBERS

5. Assemble angle braces to frame lower side members and uprights by simultaneously sliding one 45° bracket and angle brace into lower side member and the other 45° bracket down into angle brace and upright. Securely tighten all bolts (Fig. 5).

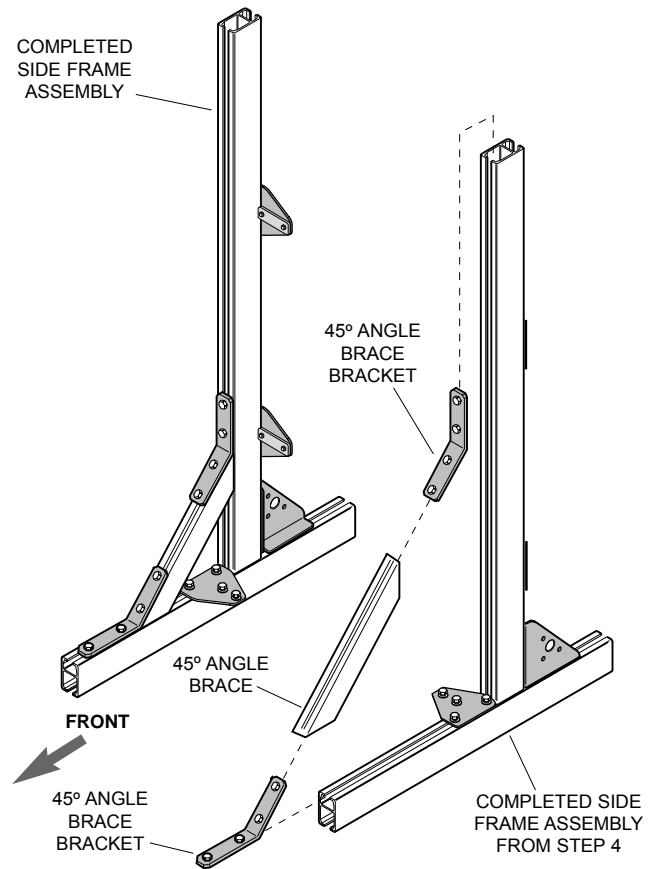


Figure 5.
INSTALLING ANGLE BRACES

- Lay one side frame flat and slide three 29" long cross members into T-plates. Slide cross members tight against side frame members and securely tighten track nut bolts (Fig 6).

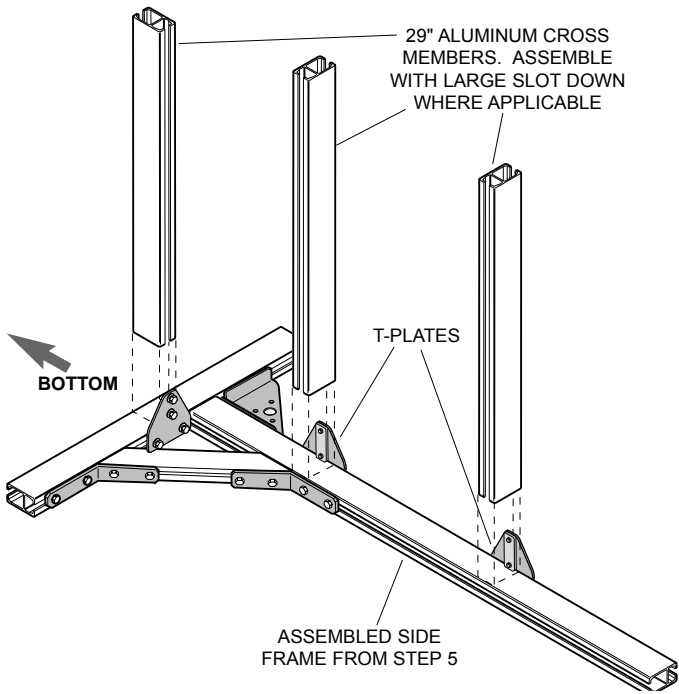


Figure 6.
INSTALLING CROSS MEMBERS

- Mount cable coil holders on top cross member using *E-Z NUTS*™ as shown (Fig 8). Securely tighten all bolts.

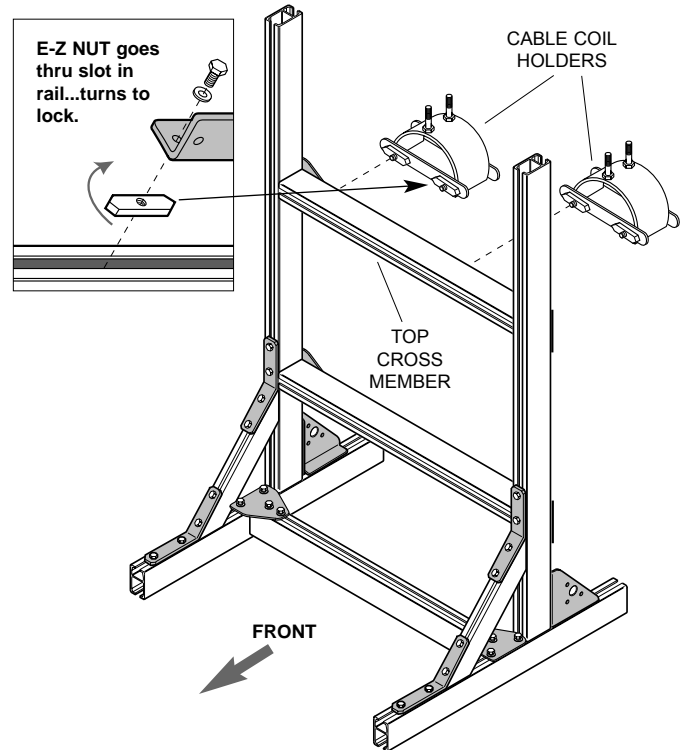


Figure 8.
INSTALLING CABLE COIL HOLDERS

- Stand assembly upright and attach other side frame (Fig 7). Square unit and securely tighten all bolts.

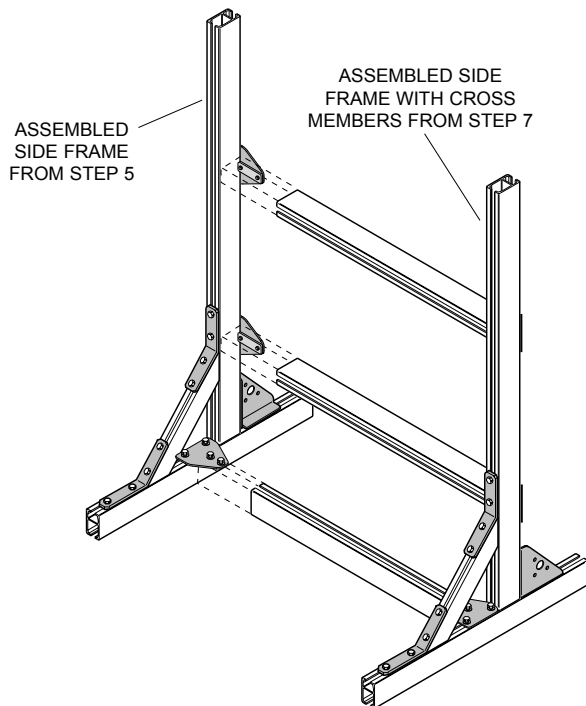


Figure 7.
COMPLETING FRAME

- Loosen clamp bars on shelf. Mount shelf to frame by sliding down from top with clamp bars inside uprights (Fig 9). Shelf back plate goes on back side of uprights. Top of back plate should be flush with top of uprights.

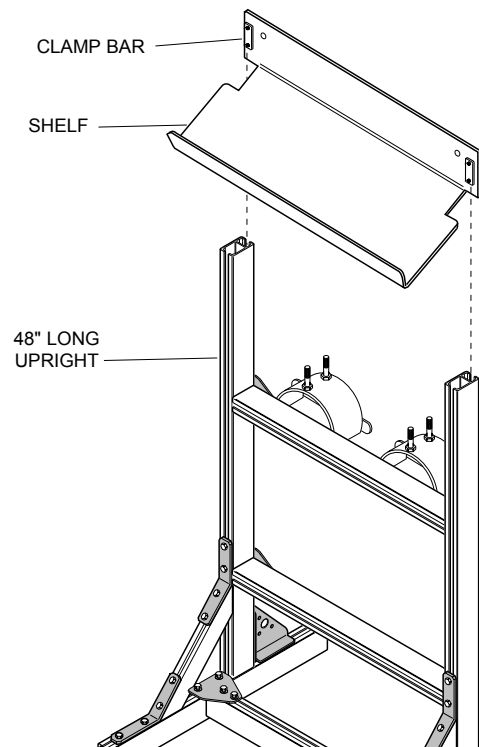


Figure 9.
ATTACHING SHELF

11. Mount Bin Bar to front of shelf with hex hd. bolts, washers and hex nuts supplied (Fig 10).

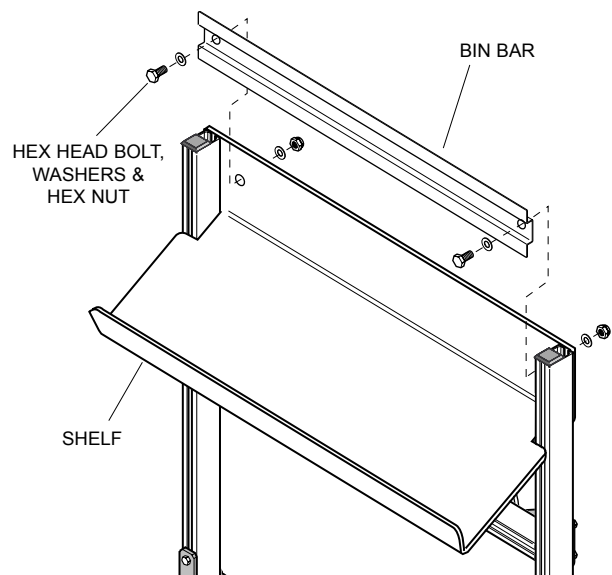


Figure 9.
INSTALLING BIN BAR

12. Install casters (Fig 10).

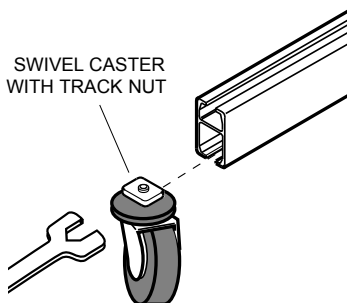


Figure 10
INSTALLING CASTERS

13. Install end caps and cover strip (Fig 11).

14. Check to make sure all bolts are tight and that unit is square (all four casters firmly on floor). Adjust as necessary.

15. Hang electrical box on cross members using **E-Z NUTS**, supplied (Fig 11). If necessary, adjust vertical spacing of cross members to fit hole spacing on box.

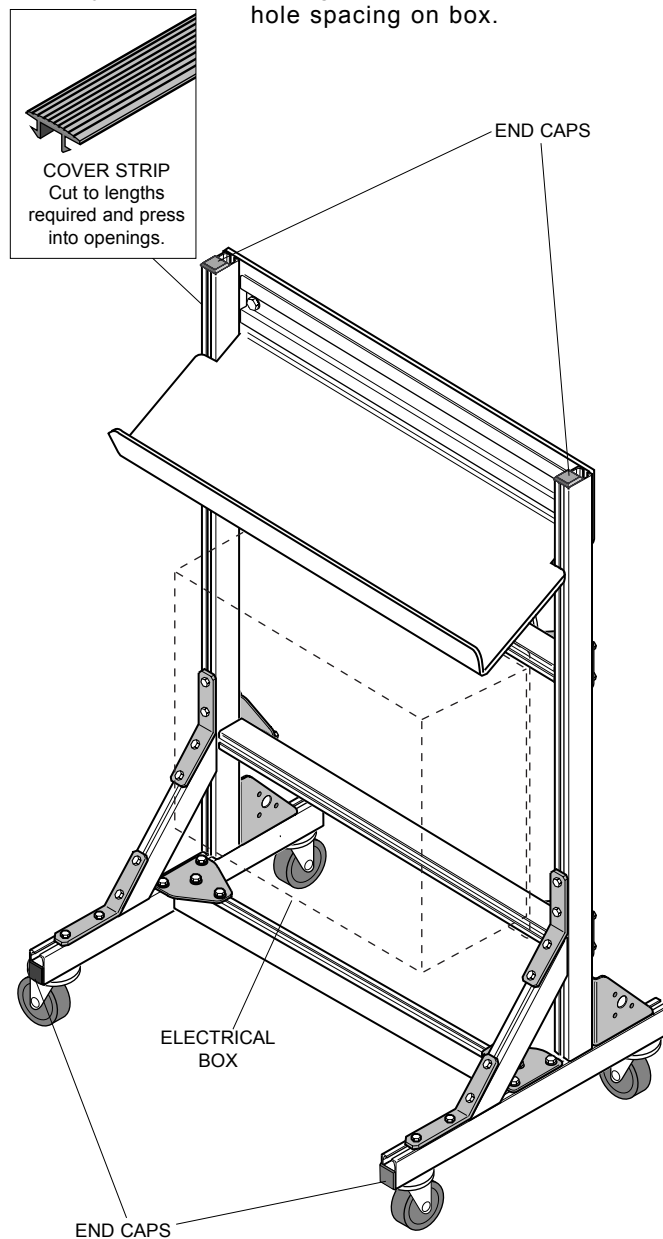


Figure 11.
COMPLETED UNIT



Workplace Solutions

600 South Clark St.
Mayville, WI 53050
Phone 920-387-4120