



GAI-TRONICS®
A HUBBELL COMPANY

Rugged VoIP Autodial Handset Telephones

TABLE OF CONTENTS

<i>Confidentiality Notice</i>	1
<i>Product Overview</i>	1
Features and Functions	2
System Requirements and Limitations	2
Tips for VoIP Subscribers	2
<i>Operation</i>	2
Place a Call	2
Receive a Call	3
Handset Receiver Volume Control	3
Monitor and Report Telephone Status	3
Status Indication	3
Power	3
Heartbeat	3
EACT	3
<i>Installation</i>	4
Safety Guidelines	4
Security Hardware	4
Conduit Installation Details (Applicable to Models 247-700 and 257-700)	4
Models 210-702, 210-702BH, and 210-702BHAC	5
Model 227-700	7
Model 247-700	9
Model 257-700	11
Model 277-700	13
Models 277-702BH and 277-702BHAC	15
Flush-mount Installation	15
Surface-Mount Installation	17
<i>Field Wiring</i>	17
Recommended Cabling	17
Power	18
Power-Over-Ethernet	18
Local Power	18
Ground (For Models 210-702BH/-702BHAC, 227-700/-702BH/-702BHAC Only)	19
Network	19

Auxiliary I/O	19
Inputs.....	19
Outputs.....	20
<i>Programming</i>	20
VoIP PCBA Setup	20
VoIP PCBA Initial Network Configuration	20
VoIP Telephone Input Contact Configuration	21
VoIP Telephone Output Contact Configuration	21
Maximum (Handset Receiver) Level Remote Control	21
<i>Maintenance</i>	21
General Information	21
Preventive Maintenance for Model 277-700/-702BH/-702BHAC	21
Cleaning.....	21
Prevention	22
Service	22
Troubleshooting	22
<i>Replacement Parts and Accessories</i>	23
<i>Specifications</i>	24
Power	24
Network	24
Handset Audio	24
Inputs	25
Outputs	25
Indicators	25
Mechanical	25
<i>Approvals</i>	26



GAI-TRONICS®
A HUBBELL COMPANY

Rugged VoIP Autodial Handset Telephones

Confidentiality Notice

This manual is provided solely as an installation, operation, and maintenance guide and contains sensitive business and technical information that is confidential and proprietary to GAI-Tronics. GAI-Tronics retains all intellectual property and other rights in or to the information contained herein, and such information may only be used in connection with the operation of your GAI-Tronics product or system. This manual may not be disclosed in any form, in whole or in part, directly or indirectly, to any third party.

Product Overview

GAI-Tronics' VoIP Autodial Handset Telephones are designed for connection to a 10/100 BaseT Ethernet network. These telephones operate from Power-over-Ethernet (PoE) or an external power source. These VoIP telephones provide direct point-to-point communications between personnel throughout a facility over an existing LAN.

The following VoIP Telephones are detailed in this manual:

Table 1. Model Chart

Model	Description
210-702	Corridor VoIP Autodial Telephone with 29-inch armored cord handset.
210-702BH	Behavioral Health VoIP Autodial Telephone with 12-inch armored cord handset.
210-702BHAC	Behavioral Health VoIP Autodial Telephone with 15-inch armored cord handset.
227-700	Tough VoIP Autodial Telephone , weather and vandal resistant sand-cast aluminum enclosure with a spring-loaded door and 15-inch armored cord handset.
247-700	Rugged Indoor VoIP Autodial Telephone , engineered plastic enclosure and handset with Hytrel® coiled cord (6-foot extended).
257-700	Rugged Weatherproof VoIP Autodial Telephone , weatherproof, engineered plastic enclosure with door and handset with Hytrel® coiled cord (6-foot extended).
277-700	Flush-panel VoIP Autodial Telephone , heavy-gauge brushed stainless steel front panel with 29-inch armored cord handset.
277-702BH	Flush-panel VoIP Behavioral Health Autodial Telephone , heavy-gauge brushed stainless steel front panel with 12-inch armored cord handset.
277-702BHAC	Flush-panel VoIP Behavioral Health Autodial Telephone , heavy-gauge brushed stainless steel front panel with 15-inch armored cord handset.

Features and Functions

The VoIP Telephones covered in this manual include the following features:

- SIP compatible (RFC3261)
- weather and/or vandal-resistant
- real-time alarm reporting via email, syslog, or TMA software
- PoE (Power-over-Ethernet) compatible
- configurable via web page, serial link or download
- four auxiliary inputs, two volt-free contact outputs

System Requirements and Limitations

These VoIP telephones require Power-over-Ethernet (PoE) or a local 24–48 V dc power source for operation. Two VoIP telephones can be connected in a peer-to-peer configuration without the need for a LAN. A 10/100 BaseT Ethernet network with a SIP (Session Initiation Protocol) server is required for systems containing three or more VoIP telephones. Conferences are limited by the customer's LAN media capabilities and the services available at each end point.

Tips for VoIP Subscribers

The following points should be addressed for new and existing subscriptions to an interconnected VoIP service provider:

- Provide accurate physical address information to the VoIP service provider to ensure that emergency services can quickly be dispatched to the location.
- Be familiar with the VoIP service provider's procedures for updating the address and promptly update address information in the event of a change.
- Have a clear understanding of any limitations of the local 911 service.
- Be aware that VoIP telephone services may not work if the power is out or the Internet connection is down. Consider installing a backup power supply, maintaining a traditional telephone line, or having a wireless telephone as a backup.
- For questions about interconnected VoIP and 911, or VoIP in general, see <http://www.fcc.gov/cgb/consumerfacts/voip.html>.

Operation

Place a Call

To place a call:

1. Lift the handset from the cradle to take the telephone off-hook.
The programmed number is automatically dialed after approximately one second.
2. Control the handset receiver volume by pressing the volume control pushbutton.
3. The call is terminated by placing handset back in the cradle, the receiving caller hangs up, the defined timeout of the call duration is exceeded, or via the SIP server.

Receive a Call

The VoIP telephone's ringer sounds when called until the handset is removed from the cradle (taken off-hook) and a conversation can take place.

Handset Receiver Volume Control

A push-button switch is provided on the front panel for adjustment of the handset receiver volume. When pressed, it decreases the volume gain from 20 dB to 12 dB, to 0 dB, and back up to 20 dB of the original signal. After the end of each call the signal gain is automatically set to 20 dB.

Monitor and Report Telephone Status

Each telephone can recognize and generate several hardware and configuration fault condition alarms. There are three methods to transmit this information to a remote site:

- syslog output over TCP
- SMTP mail message
- TMA (Telephone Management Application) software (purchased separately)

Available alarms are:

- handset integrity loop (if applicable)
- configuration error
- cold reset (power cycle)
- warm reset (internal command)
- key hook (off hook status, if applicable)
- register fail
- audio path test (speaker/microphone test)

Status Indication

Power

The power LED located on the VoIP PCBA illuminates when power is applied to the telephone (see [Figure 18](#)).



Heartbeat



The heartbeat LED located on the VoIP PCBA will flash once network communication is established (see [Figure 18](#)).

EACT

The EACT LED located on the VoIP PCBA turns ON when VoIP PCBA is connected to an Ethernet device and flashes when data is being transmitted (see [Figure 18](#)).

Installation

 **WARNING**  —This product can contain hazardous voltages. Always remove power to this station and any associated equipment before beginning any installation.

 **CAUTION**  —Do not install this equipment in areas other than those indicated on the approval listing in the Approvals section of this manual. Such installation may cause a safety hazard and consequent injury or property damage.

Install equipment without modification and according to all applicable local and national electrical codes. Consult the National Electrical Code (NFPA 70), Canadian Standards Association (CSA 22.1), and local codes for specific requirements regarding your installation. Class 2 circuit wiring must be performed in accordance with NEC.

Safety Guidelines

When installing any GAI-Tronics equipment, please adhere to the following guidelines to ensure the safety of all personnel:

- Do not install wiring during a lightning storm.
- **Electrostatic Discharge (ESD) Protection:** GAI-Tronics' VoIP telephones may have an earth ground terminal provision. Connect this terminal to ground in accordance with all local safety regulations and the NEC (National Electrical Code). Grounding must be ensured for safe and stable communications. Do not use long and coiled ground wires. Trim ground wires to the required length. Use a star configuration whenever possible. Please note proper grounding does not eliminate the need for lightning protection for the telephone or the telephone system. A Cat5 data line lightning surge protector is recommended for telephones subject to any electrostatic discharge (e.g. lightning).
- Do not install jacks in wet locations unless the jack is specifically designed for wet locations.

Security Hardware

Models 210-702BH/-702BHAC, 227-700, and 277-702BH/-702BHAC are vandal-resistant. The front enclosure or panel of these telephones is attached to its mounting plate or enclosure with security screws. A GAI-Tronics Model 233-001 Security Screwdriver or Torx T-25 security head tip (sold separately) is required to install the security screws. Models 247-700 and 257-700 Telephones' front panels are attached with standard Phillips head screws.

Conduit Installation Details (Applicable to Models 247-700 and 257-700)

GAI-Tronics recommends installing cabling in conduit to protect against accidental damage and vandalism. The following points are strongly recommended to prevent moisture from entering the enclosure:

- Conduit should enter the enclosure from the bottom.
- If entered from the top, the conduit must be internally sealed to prevent moisture ingress.
- Sealed fittings should be installed at all cable entry points.
- **Silicone sealant or equivalent must be applied around and inside all conduit entries.**

Please refer to [Figure 1](#) and [Figure 2](#).

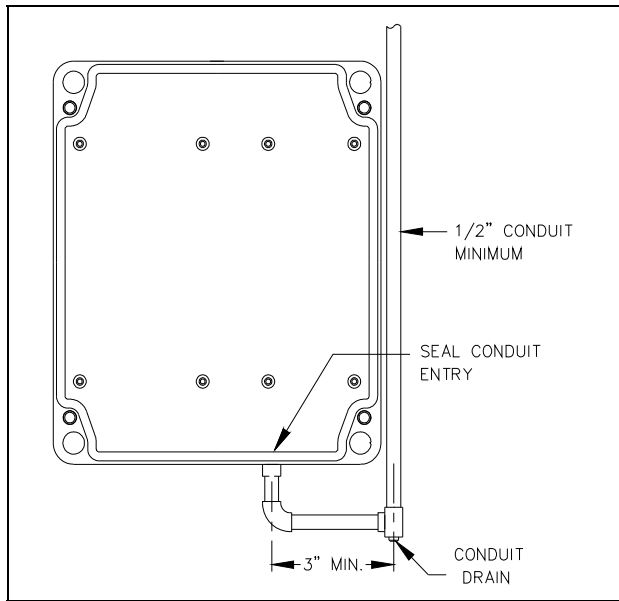

Figure 1. Model 247-700 & 257-700—Bottom entry conduit installation details

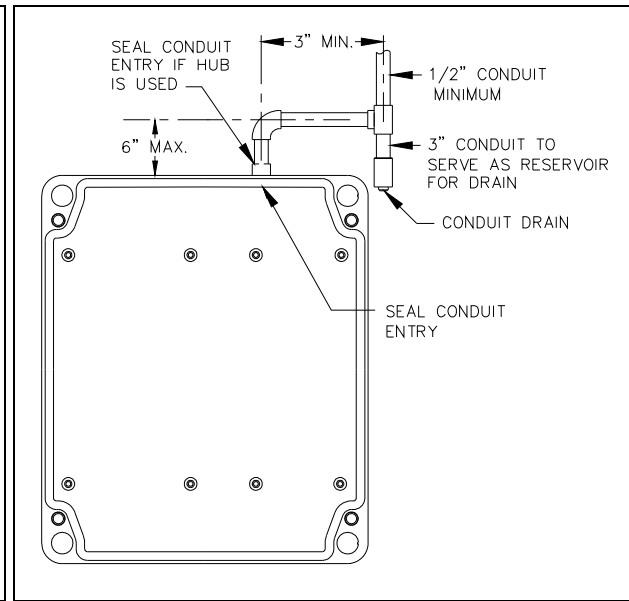

Figure 2. Model 247-700 & 257-700—Top entry conduit installation details—
(NOT RECOMMENDED)

Models 210-702, 210-702BH, and 210-702BHAC

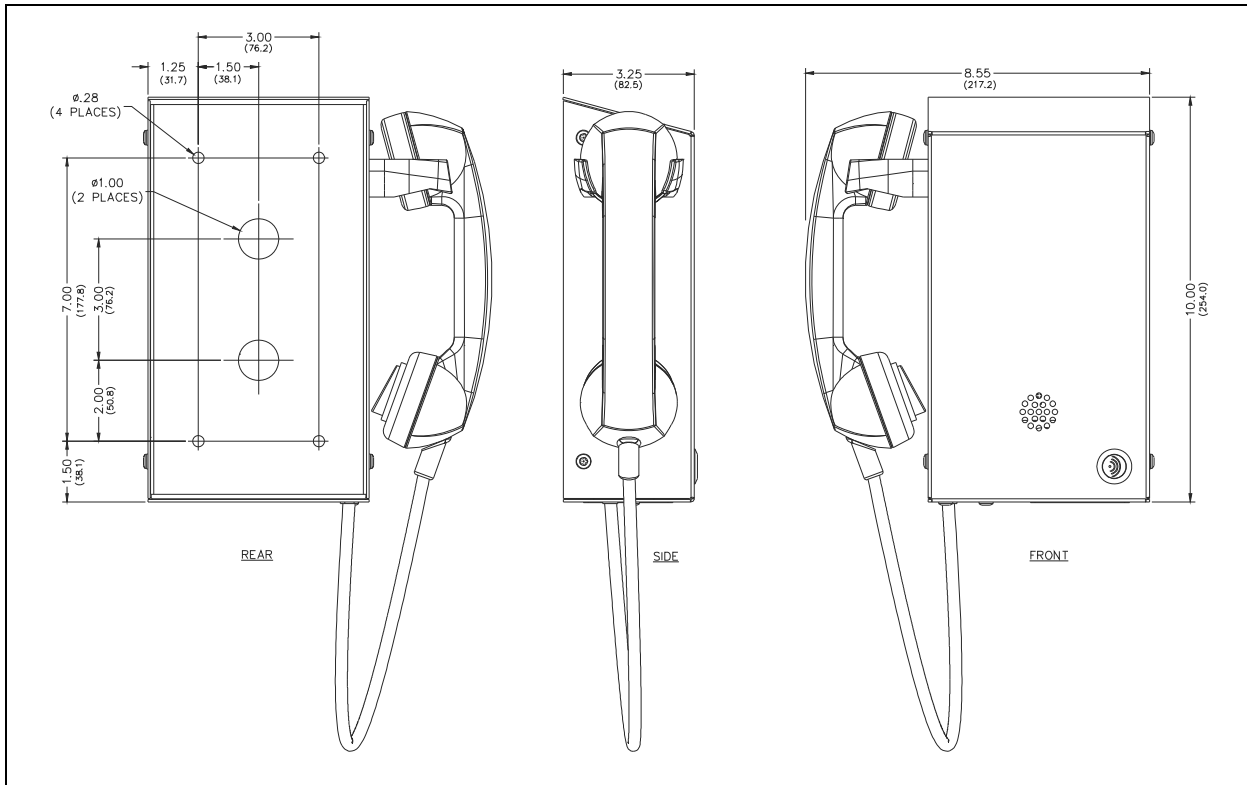

Figure 3. Models 210-702/-702BH/-702BHAC VoIP Autodial Behavioral Telephones Outline and Mounting Detail

1. Use a GAI-Tronics No. 233-001 Security Screwdriver to remove the four tamper-resistant cover-panel screws (see [Figure 4](#)).
2. Remove the front cover assembly and set it aside to expose the four mounting holes on the mounting panel.
3. Position the rear mounting panel on the mounting surface and fasten with four #10-32 screws (customer supplied).
4. Pull the Ethernet cable through one of the two holes and install the cable (see the [Network](#) section).

Two 1-inch diameter entry holes are provided on the mounting panel for cable entry.

5. Connect and configure any desired peripheral devices (see the [Auxiliary I/O](#) section).
6. Perform the initial programming of the telephone (see the [Programming](#) section).
7. Replace the front cover assembly and fasten using the four security screws removed in Step 1. Tighten the four screws using a GAI-Tronics No. 233-001 Security Screwdriver.
8. Test the telephone operation by calling to and from another telephone.
9. Test the operation of peripheral equipment.

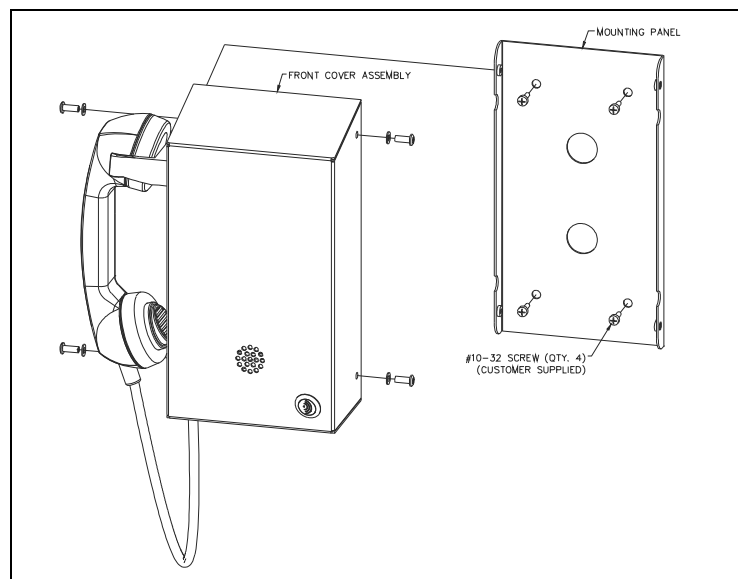

Figure 4. Models 210-702/-702BH/-702BHAC
Front Cover Removal

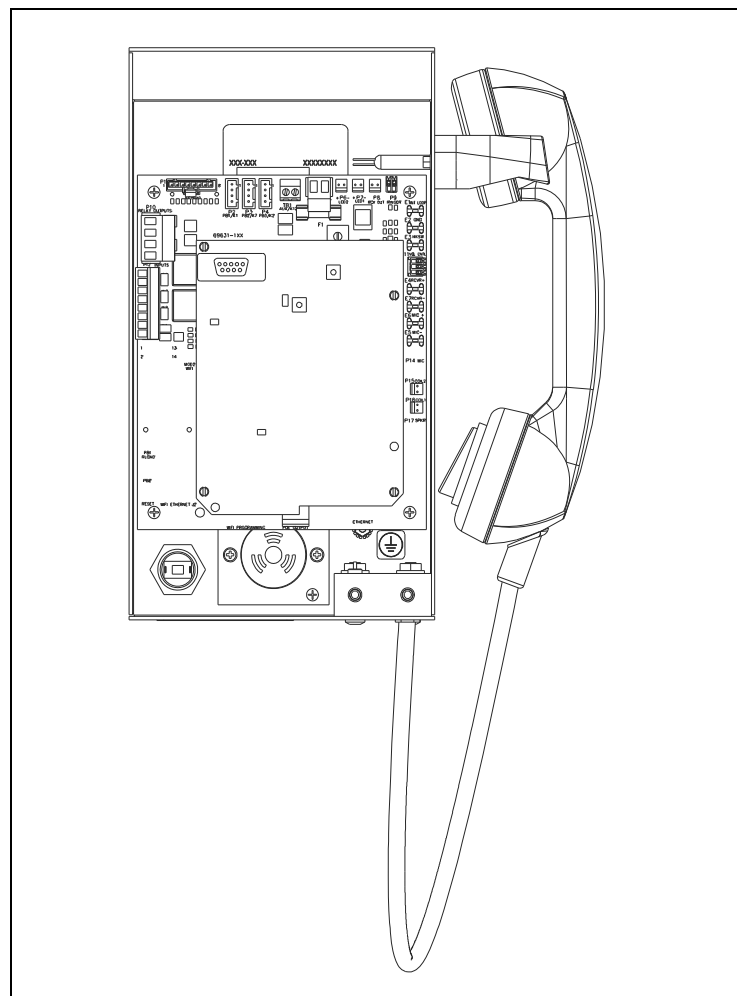

Figure 5. Models 210-702/-702BH/-702BHAC Internal View

Model 227-700

The mounting and cabling instructions for the Model 227-700 Telephone are as follows:

1. Remove the eight security screws from the front panel using a GAI-Tronics No. 233-001 Security Screwdriver.
2. Remove the front panel and set it aside.
3. Determine the hole pattern to use for mounting the telephone (see [Figure 8](#)).
 - Use the 7.875 × 4.0-inch hole pattern for mounting to a wall (outside pattern).
 - Use the 5.25 × 4.0-inch hole pattern when using the No. 232-001 Pole Mounting Kit (inside pattern).
4. Insert (four provided) hole plugs in the unused mounting holes.
5. Position the enclosure on the mounting surface and secure it with four fasteners.
 - The holes in the telephone enclosure accept 3/8-inch screws or bolts.
 - The Model 232-001 Pole Mounting Kit includes four 3/8-16 × 1-inch shoulder bolts with Teflon seal washers.

NOTE: Use only the round head, hexagon head, or pan head screws that are provided. Do not use screws designed to be countersunk for mounting the enclosure.
6. Install a conduit fitting in one of the 1/2-inch NPT conduit entrances located at the top and bottom of the unit.

The bottom location is preferred (see [Figure 7](#)).
7. Insert the conduit into the fitting.
8. Plug the unused access hole with the provided 3/8-inch Allen drive plug.

NOTE: Use silicone sealant or equivalent around and inside all conduit entries.
9. Pull the Ethernet cable through the conduit and install the cable (see the [Network](#) section).
10. Connect peripheral devices (see the [Auxiliary I/O](#) section).

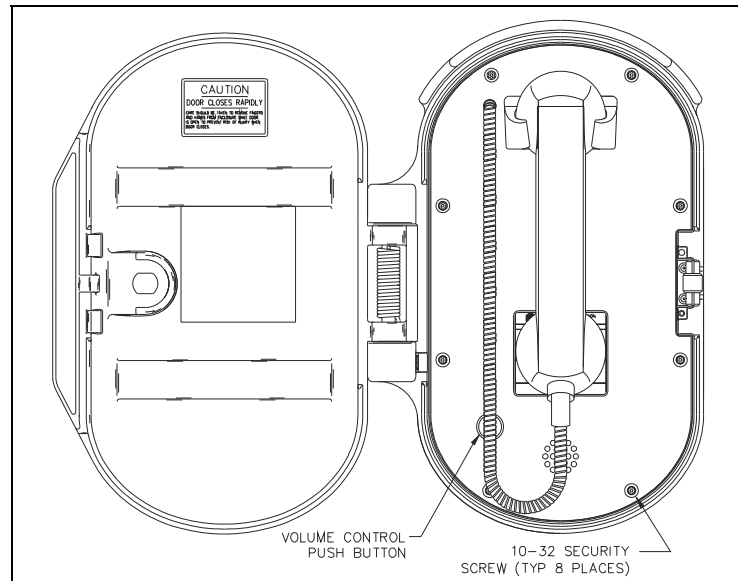

Figure 6. Model 227-700 VoIP Autodial Telephone with spring loaded door in the open position

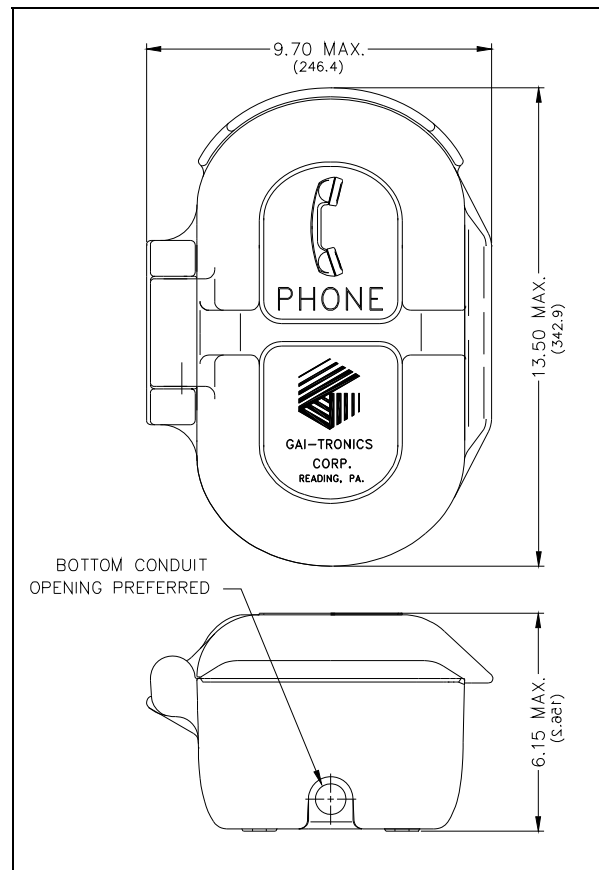

Figure 7. Model 227-700 Outline

11. Seal the conduit entry point(s).

NOTE: Use silicone sealant or equivalent around and inside all conduit entries.

12. Perform the initial programming of the telephone (see the Programming section).

13. Verify telephone operation by calling to and from another telephone.

14. Verify the operation of peripheral equipment.

15. Replace the front panel assembly and secure it using the eight front panel security screws.

16. Torque the screws to 10–12 lb-in (1.1–1.4 Nm).

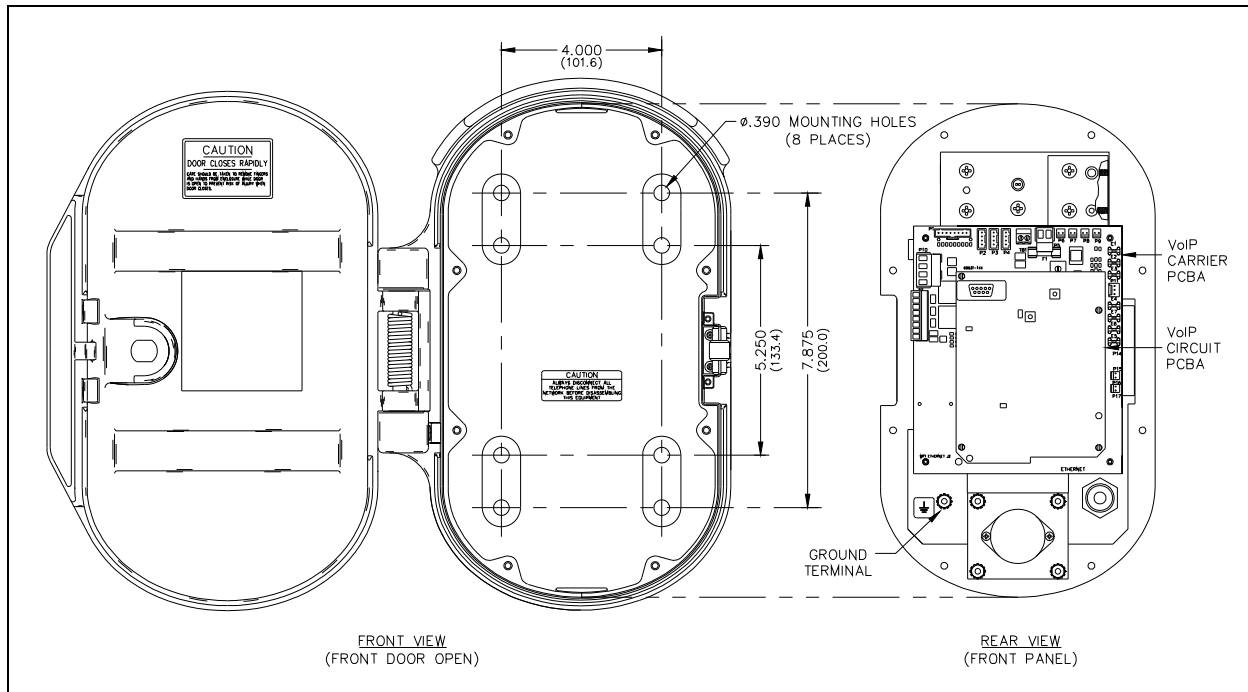

Model 247-700

The mounting and cabling instructions for the Model 247-700 Telephone are as follows:

1. Remove the four screws from the front panel.
2. Remove the front panel and set it aside.
3. Mount the enclosure to a wall using either four ¼-20 machine screws with washers and nuts or four #14 wood screws of the appropriate length, depending on the mounting surface.

There are four mounting holes in the rear enclosure (see [Figure 10](#)).

4. Drill a hole for the type of bushing to be used.
5. Pull the Ethernet cable through the bushing and install the cable (see the [Network](#) section).

6. Seal the conduit entry point.

NOTE: Use silicone sealant or equivalent around and inside all cable/conduit entries.

7. Connect and configure any desired peripheral devices (see the [Auxiliary I/O](#) section).
8. Perform the initial programming of the telephone (see the [Programming](#) section).
9. Verify telephone operation by calling to and from another telephone.
10. Test the operation of peripheral equipment.
11. Replace the front panel assembly.
12. Secure the front panel using the four front-panel screws.
13. Torque the screws to 10–12 in·lb (1.1–1.4 N·m).

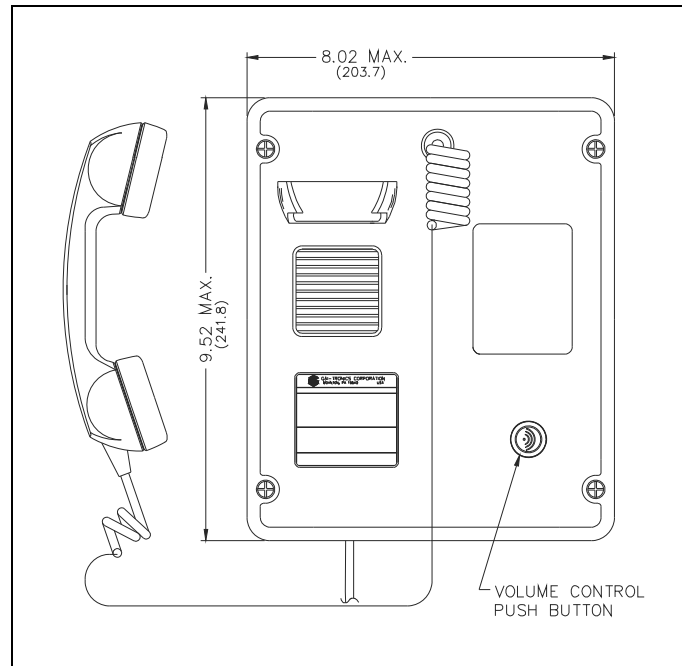

Figure 9. Model 247-700 VoIP Autodial Telephone

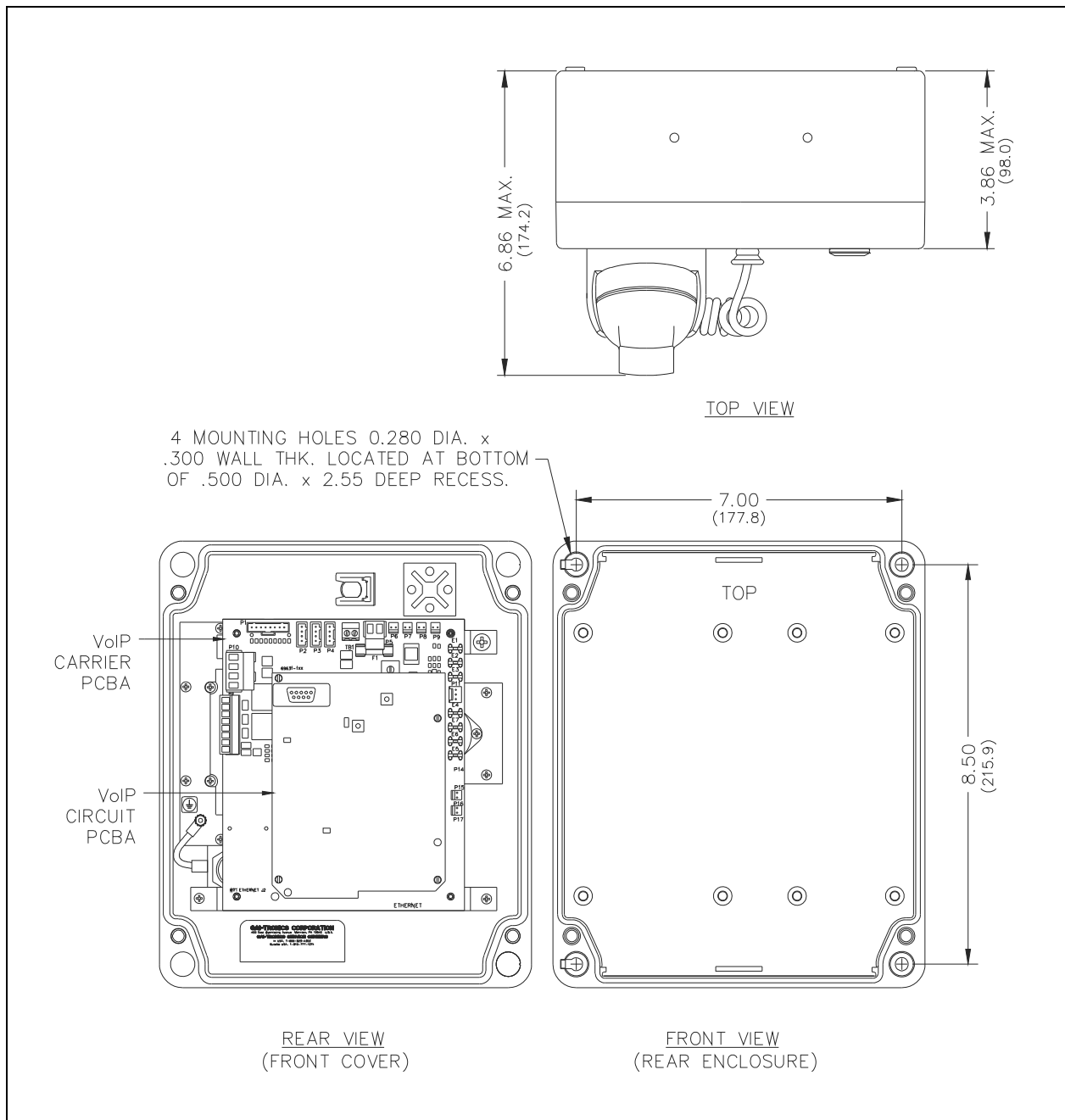

Figure 10. Model 247-700 Mounting Detail

Model 257-700

The mounting and cabling instructions for the Model 257-700 Telephone are as follows:

1. Open the front door and remove the four outer screws from the mid-section.
2. Carefully pull the enclosure apart until encountering a slight resistance on the left side.
3. Pull on the left side of the enclosure until the hinge plugs pull loose to separate the front and rear halves.
4. Set the front half of the enclosure aside.
5. Mount the enclosure on the wall using four ¼-20 machine screws with nuts and washers or #14 wood screws of the appropriate length for the mounting surface.

There are four mounting holes in the rear enclosure.

6. Drill a hole for the type of bushing to be used.
7. Reinsert the hinge pins to attach the front half of the enclosure.
8. Insert the Ethernet cable through the gland bushing and install the cable (see the [Network](#) section).

NOTE: Conduit may be used in place of the provided gland bushing. If used, the conduit entrance must be sealed after the cable is installed.

NOTE: Use silicone sealant or equivalent around and inside all conduit entries.
9. Connect peripheral devices (see the [Auxiliary I/O](#) section).
10. Perform the initial programming of the telephone (see the [Programming](#) section).
11. Verify telephone operation by calling to and from another telephone.
12. Test the operation of peripheral equipment.
13. Close the mid-section and torque the four screws to 10–12 in·lb (1.1–1.4 N·m).

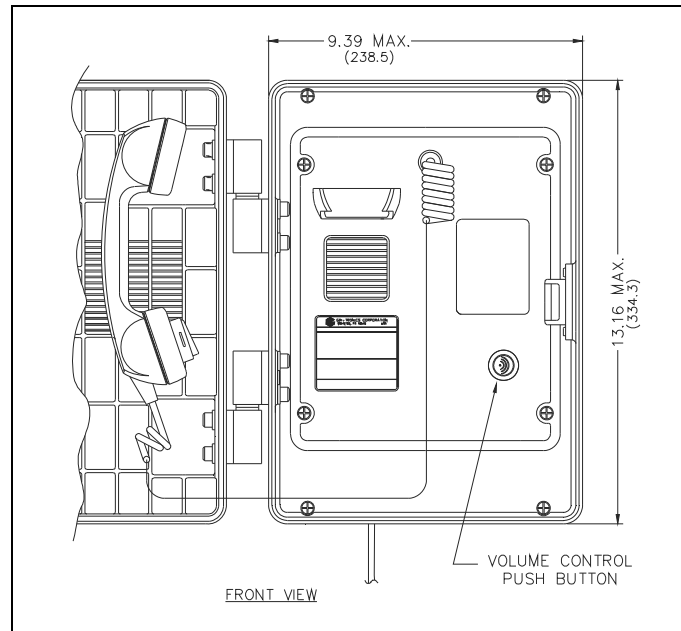

Figure 11. Model 257-700 VoIP Autodial Telephone
(Front door open)

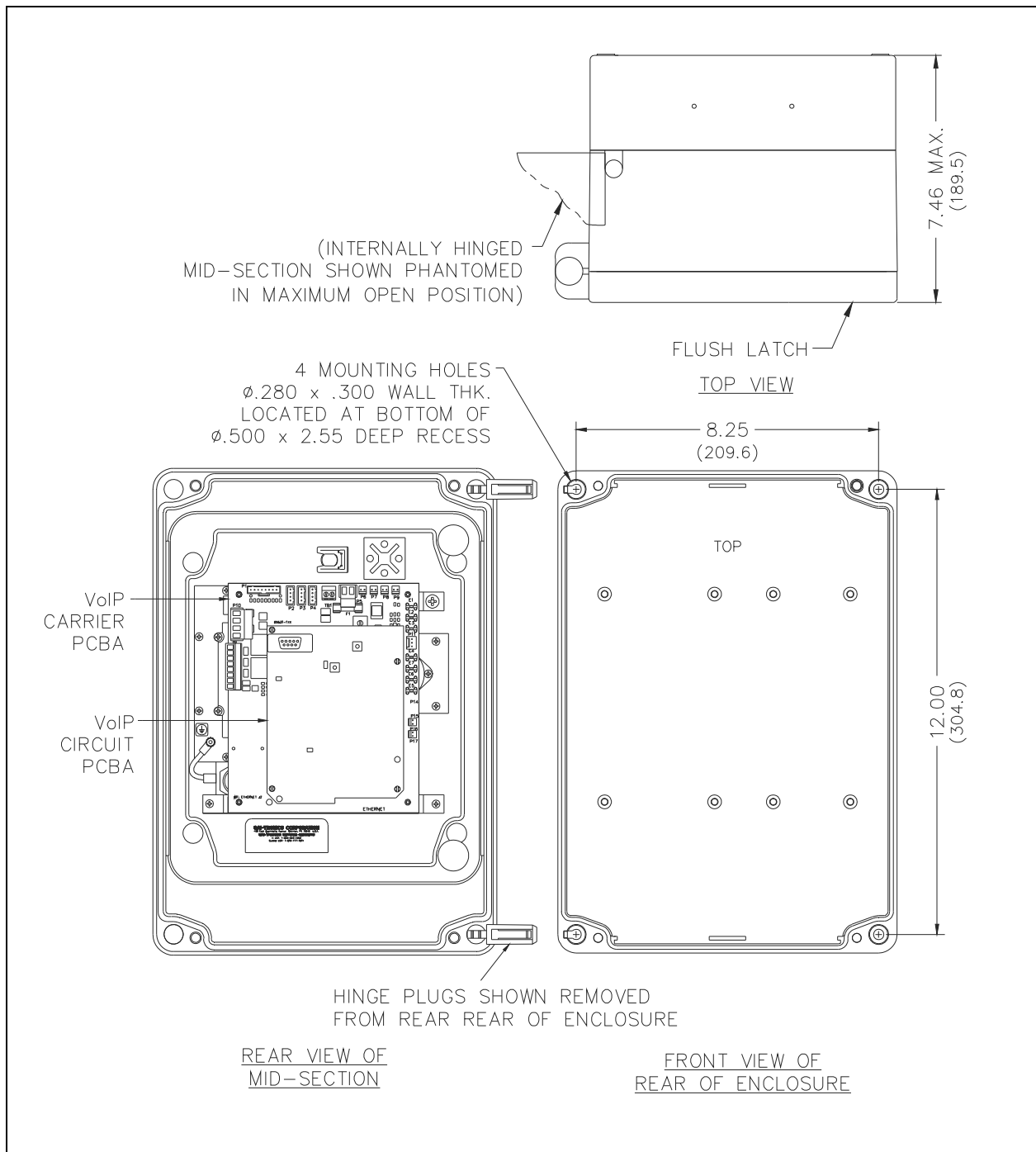

Figure 12. Model 257-700 Mounting Detail

Model 277-700

The mounting and cabling instructions for the Model 277-700 Telephone are as follows:

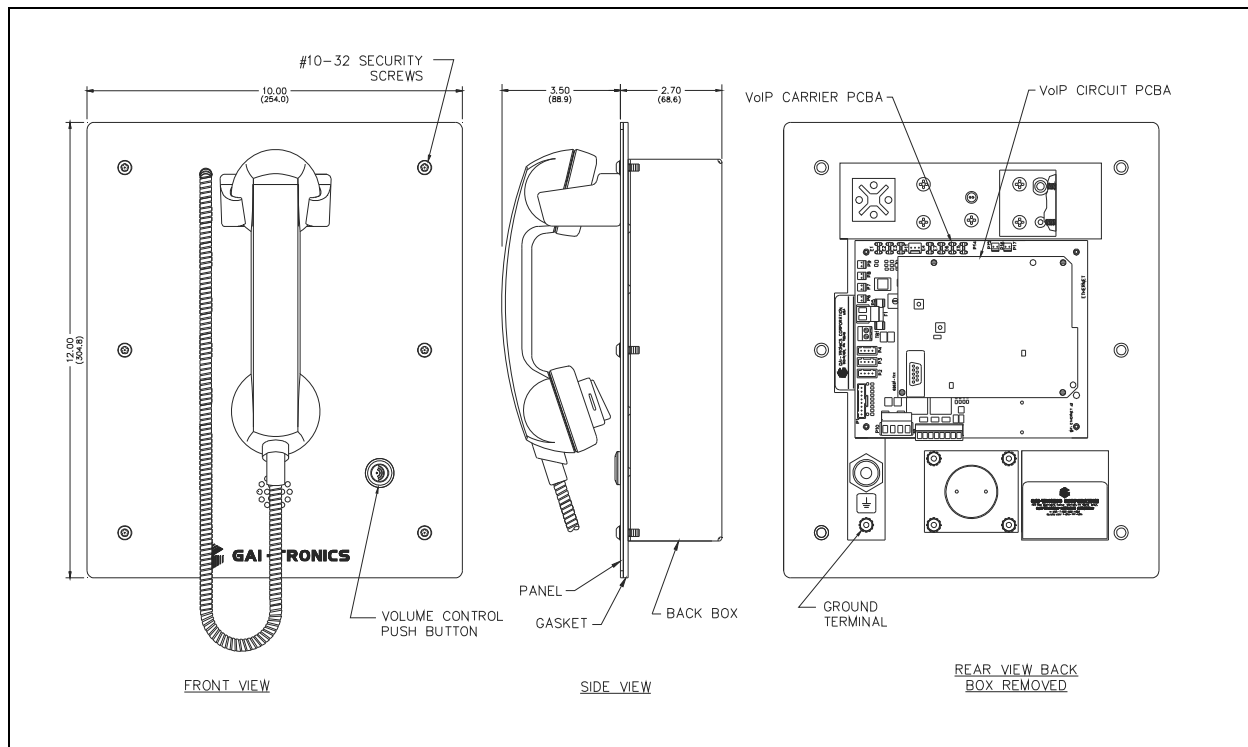

Figure 13. Model 277-700 Outline Drawing

1. Remove the six tamper-resistant screws securing the backbox to the telephone.
2. *Flush-mount and GAI-Tronics Model 234 Series Communication Station installations:*
Mount the back box to the structure using the appropriate hardware (see [Figure 14](#) for the cutout dimensions).
Surface-mount installations using a GAI-Tronics 236-00x Series or 238-001 Surface-Mount Enclosure:
Install the surface-mount enclosure following the instructions included with the enclosure.
The front panel assembly mounts directly to the enclosure (the back box is not required.)
3. Remove a tapered plug from one of the cable entry holes in the back box.
4. Install a cable fitting and pull the cabling into the backbox.
NOTE: Installation of a (customer-supplied) surge suppressor on the Ethernet cable and the power line (if used) is recommended when mounting outdoors.
NOTE: Use silicone sealant or equivalent around and inside all conduit entries.
5. Terminate all wires (see the [Field Wiring](#) section).
6. Connect all peripheral devices (see the [Auxiliary I/O](#) section).
7. Perform the initial programming of the telephone (see the [Programming](#) section).
8. Verify telephone operation by calling to and from another telephone.
9. Test the operation of peripheral equipment.

Models 277-702BH and 277-702BHAC

NOTE: See the cutout and support framing detail for installation planning (see Figure 17).

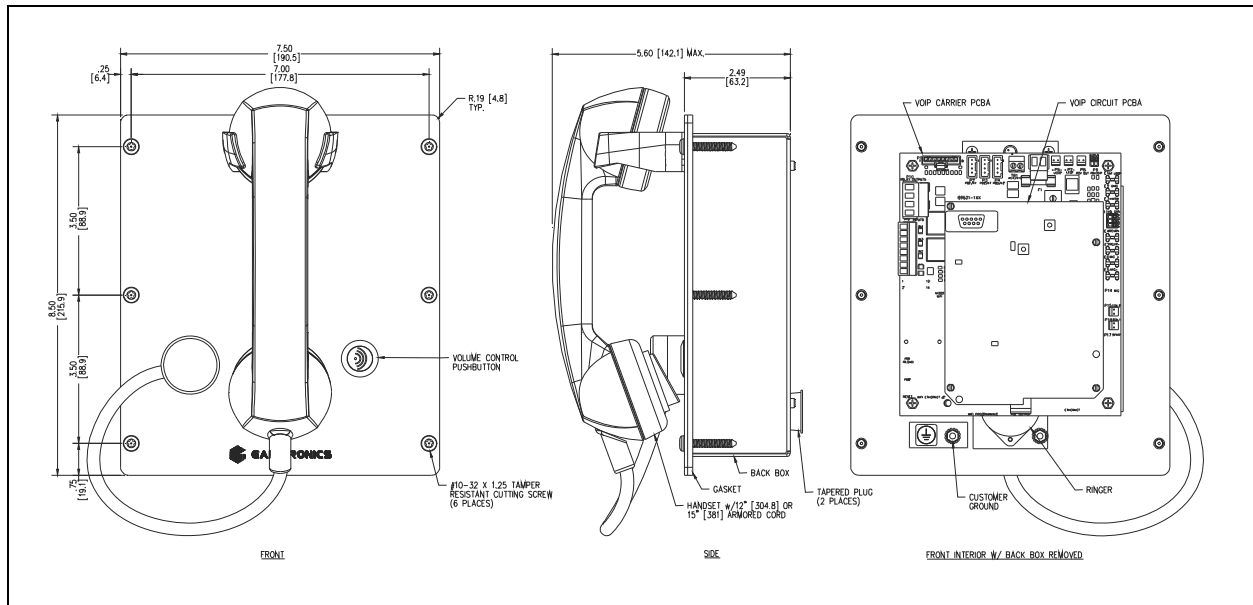

Figure 15. Models 277-702BH/-702BHAC Behavioral Health Telephone

Flush-mount Installation

1. Remove the four screws securing the dust cover to the back of the telephone and remove the dust cover.
2. Remove the tapered plug(s) from the cable entry holes and feed all cabling into the dust cover.
3. Terminate all wires (see the [Field Wiring](#) section).
4. Connect peripheral I/O devices (see the [Auxiliary I/O](#) section).
5. Reinstall the dust cover on the back of the telephone's front cover and secure it with the four screws removed in step one.
6. Perform the initial programming of the telephone (see the [Programming](#) section).
7. Verify telephone operation by calling to and from another telephone.
8. Test the operation of peripheral equipment.
9. Attach the front panel assembly to the mounting surface using the six supplied #10-32 thread-cutting security screws.

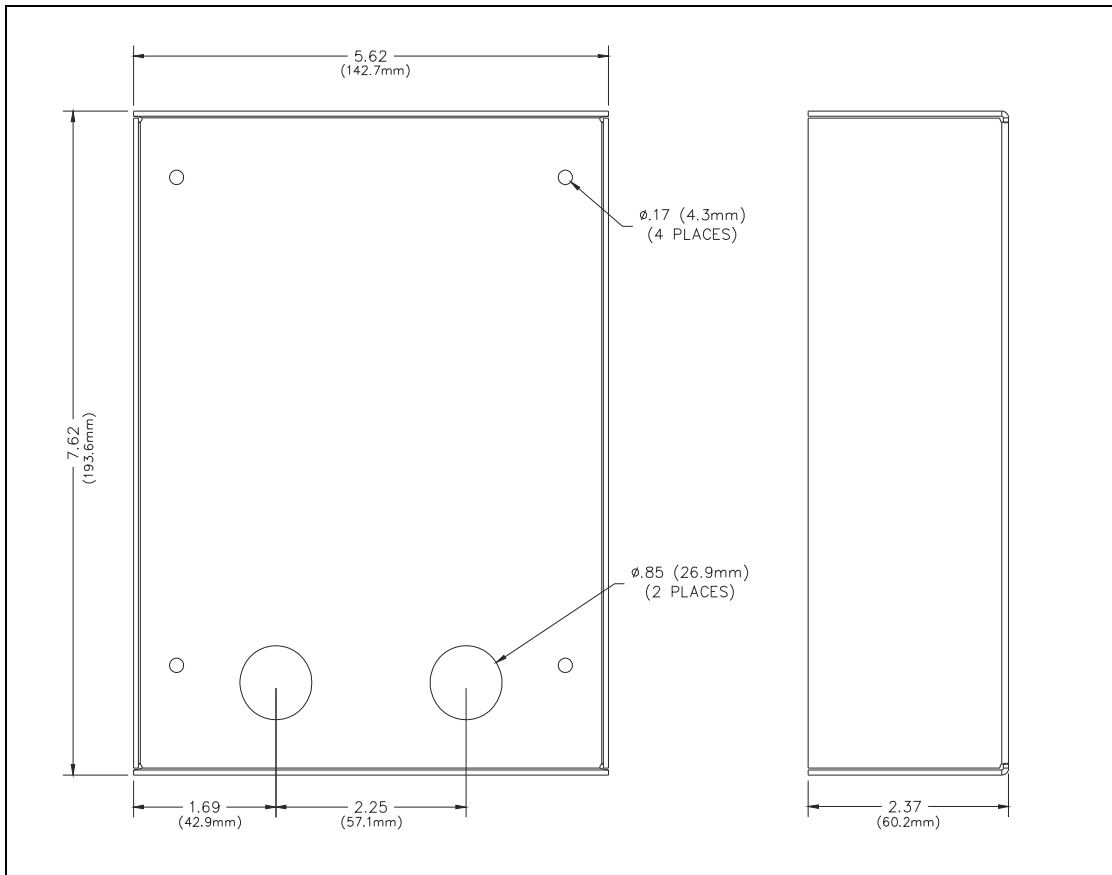

Figure 16. Models 277-702BH/-702BHAC Dust Cover Detail

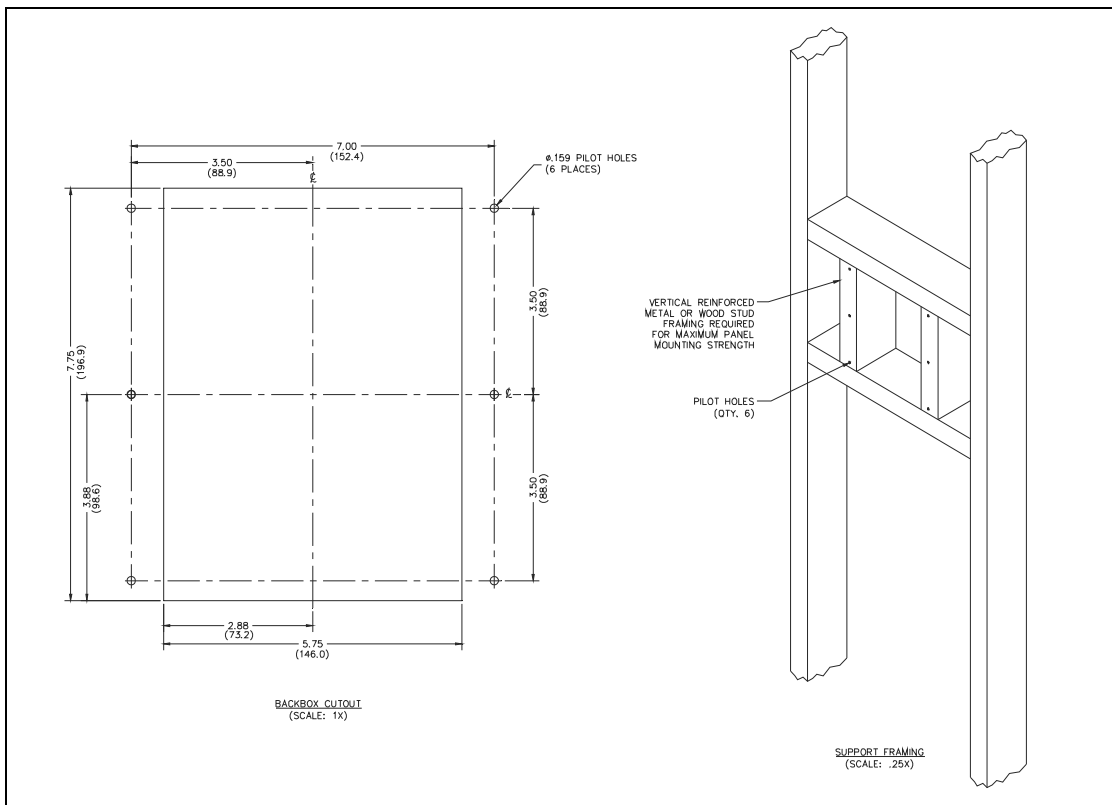

Figure 17. Models 277-702BH/-702BHAC Cutout and Support Framing Detail

Surface-Mount Installation

NOTE: a GAI-Tronics Model 238-003 stainless-steel surface-mount enclosure (sold separately) is required for surface mount installations.

1. Remove the four screws securing the dust cover to the back of the telephone and discard the dust cover.

NOTE: The dust cover included with the Model 277-702BH and 277-702BHAC telephones is not required for use with the Model 238-003 Surface-Mount Enclosure.

The Model 238-003 Enclosure includes rear and bottom access holes for cable entry. Use the rear access hole(s) for a completely hidden installation or the bottom access hole(s) for conduit installation.

2. Pull all cables into the surface-mount enclosure.
3. Terminate all cables to the telephone (see the [Field Wiring](#) section).
4. Connect and configure peripheral I/O devices (see the [Auxiliary I/O](#) section).
5. Attach the telephone's front panel to the mounting flanges of the Model 238-003 Surface-Mount Enclosure.

NOTE: Use the six #10-32 security machine screws supplied with the surface-mount enclosure kit along with the flat black washers included with the telephone. Do not use the thread-cutting screws supplied with the telephone in the Model 238-003 enclosure's tapped holes. A Model 233-001 Security Screwdriver (sold separately) is required for installing the security screws. Recommended torque is 10–12 in·lb.

Field Wiring

Install all connections after pulling the field wiring into the rear enclosure (see [Table 2](#) for recommended conductor sizes and [Figure 18](#) for wiring details).

NOTE: Consult the National Electrical Code (NFPA 70), Canadian Standards Association (CSA 22.1), and local codes for the specific requirements regarding your installation. Install all equipment without modification and according to the local and national codes. Class 2 circuit wiring must be performed in accordance with NEC 725.55.

Recommended Cabling

Table 2. Recommended Cabling

Cable Use	Size and Type
LAN	Cat5 or Cat5e cable with RJ45 connectors
Power	Two-conductor, No. 22 AWG is typical
Inputs	Two-conductor, No. 22 AWG is typical
Output contacts	Two-conductor, No. 18 AWG is typical

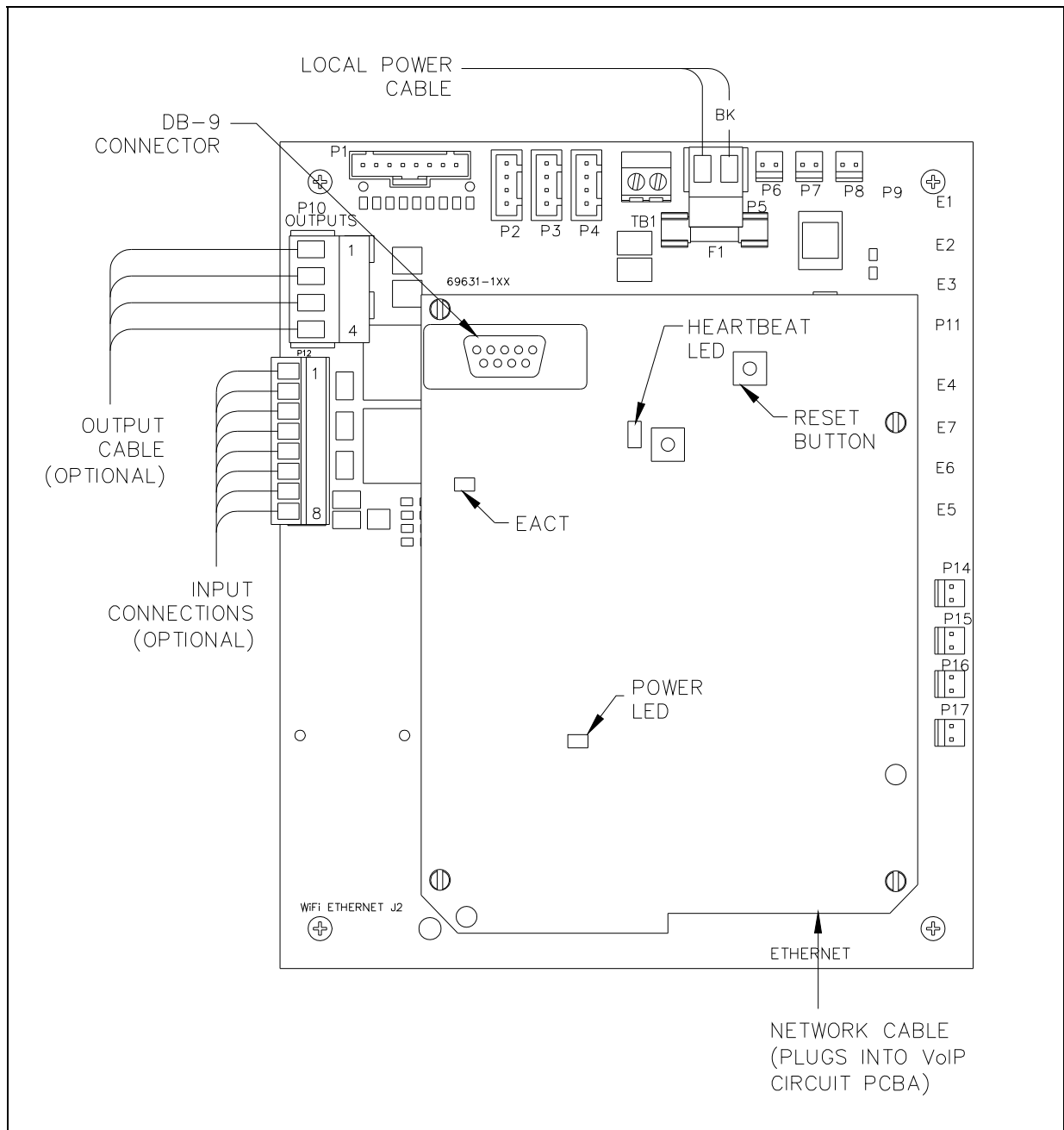

Figure 18. VoIP Telephone PCB Assembly

Power

Power-Over-Ethernet

Connect power to the system as indicated in your PoE equipment manual.

Local Power

When PoE is not available, a separate, isolated 24–48 V dc power supply is required. A removable terminal block P5 has been provided for connection of local power to the telephone. Connect the positive conductor to the (+) terminal and the negative conductor to the (–) terminal of P5 (see Table 3 and Figure 18).

Table 3. 24–48 V dc Power Connection—Terminal Block P5

Pin	Label	Description
1	(+)	Positive
2	(-)	Negative

Ground (For Models 210-702BH-702BHAC, 227-700/-702BH/-702BHAC Only)

The enclosure must be connected to earth ground. Install a #6 ring lug on the ground conductor and secure it to the ground terminal located in the rear of the front panel.

NOTE: Not applicable to Models 247-700 and 257-700.

Network

Connect a Cat5 or Cat5e cable with an RJ45 connector between the Local Area Network (LAN) and the VoIP PCBA.

Auxiliary I/O**Inputs**

Four auxiliary inputs have been provided for customer use. Terminations for these inputs are provided on terminal block P12.

Table 4. Auxiliary Inputs—Terminal Block P12

Pin	Label	Function
1	IN4	Input 4
2	COM	Common
3	IN3	Input 3
4	COM	Common
5	IN2	Input 2
6	COM	Common
7	IN1	Input 1
8	COM	Common

Outputs

Two outputs have been provided for customer use. Terminations for these outputs are provided on connector P10.

Table 5. Output Contacts—Connector P10

Pin	Label	Description
1	C1	Common Output 1
2	NO1	Normally Open Output 1
3	C2	Common Output 2
4	NO2	Normally Open Output 2

Programming

The network configuration must provide VoIP service (using the SIP protocol) between the desired locations before attempting to configure a GAI-Tronics VoIP telephone.

The general sequence to set up a VoIP telephone is as follows:

VoIP PCBA Setup

1. Connect a PC to the same network as the VoIP telephone.
2. Log into the unit's web interface.

The unit is factory configured with a static IP address: **192.168.1.2**.

3. Enter the user name and password when prompted.

The initial factory settings are:

- USER NAME: *user*
- PASSWORD: *password*

4. Change the user name and password upon first login.

This security measure helps to prevent unauthorized changes to the VoIP telephone's interface configuration.

VoIP PCBA Initial Network Configuration

Each VoIP PCBA must be set up for the network prior to installation. Assign a local ID, domain, proxy, and registrar.

Assign a host name Host names provide identification of different VoIP PCBAs on the network.

Test Verify that calls can be made successfully.

Maintain Monitor alarms. Set up auto-updates.

Refer to Pub. 42004-481 for programming instructions for these VoIP devices.

VoIP Telephone Input Contact Configuration

Each VoIP telephone accepts four volt-free inputs (see the [Specifications](#) section for the input ratings).

The function of each input is configurable. Inputs can be configured for one of the following modes: On, Off, or On/Off. The signals can also be inverted between active high (INVERT) or active low (NORMAL). Activation of these inputs can be configured to update a SYSLOG or generate an email (see [Figure 18](#) and the Logic Settings section of GTC Pub. 42004-481, VoIP Telephone Configuration Guide for programming instructions for these inputs).

VoIP Telephone Output Contact Configuration



Each VoIP telephone contains two volt-free output contacts (see the [Specifications](#) section for the output ratings). Both outputs are SPST (single-pole, single-throw) contacts.

The function of each output is configurable. Outputs can be configured for one of the following modes: On, Off, Pulse, Mute, Ring, Call, Connect, Hook, In Use, Ring Cadence, Ring Out, Page, Registered, or Emergency. In some modes, the duration of the activation or on/off times can also be set (see [Figure 18](#) and the Logic Settings section of GTC Pub. 42004-481, VoIP Telephone Configuration Guide for programming instructions for these outputs).

Maximum (Handset Receiver) Level Remote Control

The receiver volume level can be remotely controlled by changing the setting in the configuration file. Refer to the Handset Volume Setting in the Audio Settings section of Pub. 42004-481, VoIP Telephone Configuration Guide for programming instructions.

Maintenance

 **WARNING**  —This product can contain hazardous voltages. Always remove power to this station prior to servicing.

General Information

1. Inspect and replace frayed or cracked wiring.
2. Secure/replace loose wires and terminal lugs.
3. Remove corrosion from terminals.
4. Inspect fuse F1 on the VoIP carrier PCBA.

Preventive Maintenance for Model 277-700/-702BH/-702BHAC

Stainless steel does require maintenance to prevent corrosion from occurring. Different installation locations may require more regular maintenance than others, depending on the environment and exposure to airborne contaminants. The following maintenance steps should be performed on a regular basis or when corrosion is first noticed on your Model 277-700/-702BH/-702BHAC Telephone.

Cleaning

For general cleaning, wipe surface with a cleanser or cleanser and water mixture. Any cleanser that is safe for glass is usually safe for stainless steel. Wipe dry.

If corrosion or rusting is noticed, remove with a non-abrasive commercial cleanser and water. Rub stained areas in the same direction as the existing grain. Stubborn stains may be removed with a paste made from magnesium oxide, ammonia, and water. Wipe clean, water rinse, and dry.

Prevention

Automotive wax provides the best results in preventing corrosion on stainless steel. Simply apply wax, let dry to a haze, and buff to a shine with a clean dry cloth. This application should protect the telephone surface for many months as it will allow naturally re-formation of the chromium oxide layer.

DO NOT use steel wool, sandpaper, mineral acids, bleaches, or chlorine cleansers on stainless steel.

Service

Contact a regional service center for an RA# (return authorization number) if the telephone requires service. Equipment must be shipped prepaid to GAI-Tronics with a return authorization number and a purchase order number. Repairs or a replacement will be made in accordance with GAI-Tronics' warranty policy if the equipment is under warranty. Please include a written explanation of all defects to assist our technicians in their troubleshooting efforts.

Call 800-492-1212 inside the USA or 610-777-1374 outside the USA for help identifying the Regional Service Center closest to you.

Troubleshooting

Table 6. Troubleshooting Chart

Problem	Possible Solution
Low volume	Increase the volume level in the telephone's programming configuration.
High volume	Decrease the volume level in the telephone's programming configuration.
Front panel push buttons are not operational	<ul style="list-style-type: none"> • Verify the push buttons are properly configured. • Verify power is applied to the unit.
Inputs not operational	<ul style="list-style-type: none"> • Check the input connections. • Verify the inputs are properly configured.
Outputs not operational	<ul style="list-style-type: none"> • Check the output connections. • Verify the outputs are properly configured.
Cannot make or receive calls	<ul style="list-style-type: none"> • Check the connection of the LAN cable. • Verify that power is applied to the unit. • Verify the LAN parameters have been configured properly. • Verify the telephone has been set up on the network.
No power indication	<ul style="list-style-type: none"> • Check the power connections. • If using PoE, check the operation of the PoE equipment.

Replacement Parts and Accessories

Table 7. Replacement Parts by Model Number

Part No.	Description	210-702	210-702BH	210-702BHAC	227-700	247-700	257-700	277-700	277-702BH	277-702BHAC
10113-020	Handset Assembly with Armored Cord, 15-inch			■	■					■
10113-021	Handset Assembly with Armored Cord, 29-inch	■						■		
10113-022	Hytrel® Cord Handset Assembly, 6-foot					■	■			
10113-030	Handset Assembly with Armored Cord, 12-inch		■						■	
12512-001	Hookswitch/Assembly Kit (plastic)	■	■	■		■	■		■	■
12512-002	Hookswitch/Assembly Kit (metallic)				■			■		
12516-001	Replacement Mounting Screw Kit (Phillips, #10-32 × 1 1/8-inch, 10 pack)					■	■			
12516-002	Replacement Mounting Screw Kit (Security, #10-32 × 1/2-inch carbon screw, 10 pack)				■					
12542-002	Replacement Mounting Screw Kit (Security, #10-32 × 1/2-inch machine screw, 15 pack)	■	■	■				■		
12542-003	Replacement Mounting Screw Kit (Security, #10 × 1 1/4-inch thread-cutting screw, 15 pack)								■	■
12565-701	VoIP Carrier PCBA Replacement Kit	■	■	■	■	■	■	■	■	■
13707-008	Ringer, Panel-Mount				■	■	■	■		
13707-015	Ringer, Panel-Mount	■	■	■					■	■

Table 8. Available Accessories by Model Number

Part No.	Description	210-702	210-702BH	210-702BHAC	227-700	247-700	257-700	277-700	277-702BH	277-702BHAC
233-001	Model 233-001 Security Screwdriver	■	■	■	■			■	■	■
230-001	Pole Mounting Kit, Rugged Phone/RF Call Box						■			
231-001FS	Pole Mounting Kit for FS/BH Series Telephones when installed in a No. 238-003 Enclosure								■	■
231-002	Pole Mounting Kit for Model 247-700 and for Model 277-700 when installed in a No. 238-001 Enclosure					■		■		
232-001	Pole Mounting Kit, (22x Series)				■					
238-001	Surface-Mount Enclosure, Stainless Steel, Standard							■		
238-003	Surface-Mount Enclosure, Stainless Steel, BH Telephones								■	■
40419-011	Optional Plug-in Power Supply, 120/240 V ac input, 24 V dc output	■	■	■	■	■	■	■	■	■

Specifications

Power

Network power..... Power-over-Ethernet, 802.3af compliant (via RJ45)
Local power requirements.....24–48 V dc, 6 W

Network

Topology 10/100 BaseT Ethernet
Cabling Category 5 or Category 5e UTP with RJ45 jacks
AddressingStatic IP provisioning or DHCP STUN client (NAT traversal)
Call control signaling SIP (RFC3261 compliant) loose routing
ConfigurationEmbedded web server
Configuration file download
Direct serial connection
Password protection

Handset Audio

Analog microphone gain30 dB
Analog earpiece gain Default: +20 dB
Setting 2: +12 dB

Setting 3: 0 dB

Frequency response..... 250 Hz to 6500 Hz
 Frequency response flatness 3 dB minimum
 THD @ 1 kHz 1% minimum

Inputs

Push button Volume control
 Configurable inputs (quantity = 4)..... Internal pull-up 3.3 V dc tolerant

Outputs

Output 1 8 A @ 30 V ac/dc (resistive load)
 Output 2 8 A @ 30 V ac/dc (resistive load)

Indicators

Internal on VoIP PCBA Power, Heartbeat, & EACT LEDs

Mechanical

Temperature range
 Operating -4 °F to +131 °F (-20 °C to +55 °C)
 Storage -40 °F to 158 °F (-40 °C to +70 °C)
 Relative humidity Up to 95%, non-condensing
 PCBA (printed circuit board assembly) Conformal coated

Models 210-702/-702BH/-702BHAC

Enclosure Construction 16-guage (0.060 in) type 304 stainless steel
 Dimensions 10.00 H × 5.50 W × 3.27 D in (254 × 139.7 × 83.1 mm)
 Handset/cord
 210-702 G-style with 29-inch armored cord
 210-702BH G-style with 12-inch armored cord
 210-700BHAC G-style with 15-inch armored cord
 Weight 5.5 lb (2.5 kg)

Model 227-700

Construction
 Enclosure Thick-walled cast aluminum with protective gray coating
 Panel 0.125-inch brushed aluminum
 Dimensions 13.50 H × 9.70 W × 6.15 D inches (342.9 × 246.4 × 156.2 mm)
 Handset/cord G-style with 19-inch armored cord and internal lanyard
 Mounting Eight 0.39-inch diameter holes
 Weight 14.5 lb (6.58 kg)

Model 247-700

Construction Engineered plastic enclosure
 Dimensions 9.50 H × 8.00 W × 6.90 D in (241.3 × 203.2 × 175.3 mm)
 Handset/cord Hytrel® cord (6-foot) with noise-canceling microphone
 Mounting Four 0.28-inch diameter holes
 Weight 4.8 lb (2.18 kg)

Model 257-700

Construction.....	Engineered plastic enclosure
Dimensions	13.20 H × 9.40 W × 7.40 D in (335.4 × 238.8 × 188.0 mm)
Handset/cord	Hytrel® cord (6-foot) with noise-canceling microphone
Mounting.....	Four 0.28-inch diameter holes
Weight.....	10.0 lb (4.54 kg)

Model 277-700

Construction

Front Panel.....	14-gauge (0.075-inch) type 304 brushed stainless steel
Back Box.....	16-gauge (0.060 in) steel with black polyurethane finish

Dimensions

Front panel	12.00 H × 10.00 W in (304.8 × 254.0 mm)
Back box (overall).....	10.06 H × 8.43 W × 2.50 D in (255.5 × 214.1 × 63.5 mm)
Handset/cord	G-style with 29-inch armored cord and internal lanyard
Cutout for mounting back box	10.13 H × 7.63 W in (257.3 × 193.8 mm)
Weight.....	7.0 lb (3.18 kg)

Models 277-702BH/-702BHAC

Construction

Front Panel.....	14-gauge (0.075 in) type 304 brushed stainless steel
Back Box.....	16-gauge (0.060 in) cold rolled steel with black polyurethane finish

Dimensions

Front Panel.....	8.50 H × 7.50 W in (215.9 × 190.5 mm)
Back Box (overall).....	7.62 H × 5.62 W × 2.31 D in (193.5 × 142.7 × 58.7 mm)

Handset/cord

277-700BH.....	G-style with 12-inch armored cord
277-700BHAC	G-style with 15-inch armored cord

Weight (approximate)	5 lb (2.3 kg)
----------------------------	---------------

Approvals

Models All:

Compliance to Standard.....	FCC CFR 47 Part 15
-----------------------------	--------------------

Models 227, 247, 257, and 277:

Safety of Information Technology Equipment	UL/CSA 60950
--	--------------

Models 227, 257, and 277 only:

Enclosure for Electrical Equipment	Type 3R
--	---------

NOTE: This equipment has been tested and found to comply with the limits for a Class A digital device, pursuant to part 15 of the FCC Rules. These limits are designed to provide reasonable protection against harmful interference when the equipment is operated in a commercial environment. This equipment generates, uses, and can radiate radio frequency energy and, if not installed and used in accordance with the instruction manual, may cause harmful interference to radio communications. Depending upon the wiring and features used on this device, additional precautions may be necessary not to cause harmful interference. Operation of this equipment in a residential area is likely to cause harmful interference, in which case the user will be required to correct the interference at their own expense.

Warranty

Equipment. GAI-Tronics warrants for a period of one (1) year from the date of shipment, that any GAI-Tronics equipment supplied hereunder shall be free of defects in material and workmanship, shall comply with the then-current product specifications and product literature, and if applicable, shall be fit for the purpose specified in the agreed upon quotation or proposal document. If (a) Seller's goods prove to be defective in workmanship and/or material under normal and proper usage, or unfit for the purpose specified and agreed upon, and (b) Buyer's claim is made within the warranty period set forth above, Buyer may return such goods to GAI-Tronics nearest depot repair facility, freight prepaid, at which time they will be repaired or replaced, at Seller's option, without charge to Buyer. Repair or replacement shall be Buyer's sole and exclusive remedy. The warranty period on any repaired or replacement equipment shall be the greater of the ninety (90) day repair warranty or one (1) year from the date the original equipment was shipped. In no event shall GAI-Tronics warranty obligations with respect to equipment exceed 100% of the total cost of the equipment supplied hereunder. Buyer may also be entitled to the manufacturer's warranty on any third-party goods supplied by GAI-Tronics hereunder. The applicability of any such third-party warranty will be determined by GAI-Tronics.

Services. Any services GAI-Tronics provides hereunder, whether directly or through subcontractors, shall be performed in accordance with the standard of care with which such services are normally provided in the industry. If the services fail to meet the applicable industry standard, GAI-Tronics will re-perform such services at no cost to buyer to correct said deficiency to Company's satisfaction provided any and all issues are identified prior to the demobilization of the Contractor's personnel from the work site. Re-performance of services shall be Buyer's sole and exclusive remedy, and in no event shall GAI-Tronics warranty obligations with respect to services exceed 100% of the total cost of the services provided hereunder.

Warranty Periods. Every claim by Buyer alleging a defect in the goods and/or services provided hereunder shall be deemed waived unless such claim is made in writing within the applicable warranty periods as set forth above. Provided, however, that if the defect complained of is latent and not discoverable within the above warranty periods, every claim arising on account of such latent defect shall be deemed waived unless it is made in writing within a reasonable time after such latent defect is or should have been discovered by Buyer.

Limitations / Exclusions. The warranties herein shall not apply to, and GAI-Tronics shall not be responsible for, any damage to the goods or failure of the services supplied hereunder, to the extent caused by Buyer's neglect, failure to follow operational and maintenance procedures provided with the equipment, or the use of technicians not specifically authorized by GAI-Tronics to maintain or service the equipment. **THE WARRANTIES AND REMEDIES CONTAINED HEREIN ARE IN LIEU OF AND EXCLUDE ALL OTHER WARRANTIES AND REMEDIES, WHETHER EXPRESS OR IMPLIED BY OPERATION OF LAW OR OTHERWISE, INCLUDING ANY WARRANTIES OF MERCHANTABILITY OR FITNESS FOR A PARTICULAR PURPOSE.**

Return Policy

If the equipment requires service, contact your Regional Service Center for a return authorization number (RA#). Equipment should be shipped prepaid to GAI-Tronics with a return authorization number and a purchase order number. If the equipment is under warranty, repairs or a replacement will be made in accordance with the warranty policy set forth above. Please include a written explanation of all defects to assist our technicians in their troubleshooting efforts.

Call 800-492-1212 (inside the USA) or 610-777-1374 (outside the USA) for help identifying the Regional Service Center closest to you.