



GAI-TRONICS®  
A HUBBELL COMPANY

# Industrial Communication System Zone 2/22 Weatherproof Page/Party® Station

## TABLE OF CONTENTS

*Confidentiality Notice* ..... 1

*General Information* ..... 1

**Product Overview** ..... 1

**Features**..... 2

**Options** ..... 2

*Installation* ..... 2

**Important Safety Instructions**..... 2

**Front Panel Removal** ..... 3

**Cable Entries** ..... 4

**Enclosure Installation** ..... 4

**Field Wiring**..... 5

**Speaker Impedance Configuration**..... 6

**Front Panel Installation**..... 7

*Configuration* ..... 7

**Front Panel Removal** ..... 7

**Jumper Configuration** ..... 7

        Speaker Mute ..... 8

        Speaker Gain ..... 8

**Level Adjustments** ..... 8

        Transmit Level ..... 8

        Receiver Volume ..... 8

        Speaker Volume ..... 8

**Front Panel Installation**..... 9

*Operation* ..... 9

*Options*..... 10

**ICS SmartSeries®** ..... 10

        General ..... 10

        Features ..... 10

        Installation ..... 11

            Front Panel Removal ..... 11

SmartSeries® PCBA Installation .....	11
Configuration .....	11
Station Address .....	11
ALS Minimum Level .....	11
ALS Offset Level .....	12
SmartSeries® VLC Level .....	12
Speaker Impedance Supervision .....	13
FSK Signal Gain .....	13
Front Panel Installation .....	13
Operation.....	13
Paging with ADVANCE Head End .....	13
Paging without ADVANCE Head End .....	14
Station Time-out Features .....	14
All-Call Paging Utilizing a Merge/Isolate Cabinet .....	14
SmartSeries® Dual Page All-Call Utilizing ADVANCE Head End .....	14
EPL (Emergency Party Line).....	15
Paging with Alternate Page Destination Utilizing ADVANCE Head End .....	16
<b>VLC .....</b>	<b>17</b>
General.....	17
Features .....	17
Installation.....	18
Front Panel Removal.....	18
VLC PCBA Installation .....	18
Configuration .....	18
50 kHz Alignment.....	18
Speaker Mute .....	18
Audio Alignment .....	18
Page Disable Control .....	19
Remote Output Switching (Available with RTU Only).....	19
Front Panel Installation .....	19
<b>RTU .....</b>	<b>19</b>
General.....	19
Features .....	20
With SmartSeries® PCBA and ADVANCE Head End .....	20
With SmartSeries® PCBA and Dual Page All-Call with ADVANCE Head End .....	20
With VLC PCBA .....	20
Installation.....	20
Front Panel Removal.....	20
RTU PCBA Installation .....	21
Field Wiring .....	21
Front Panel Installation .....	24
<b>DC Power Option.....</b>	<b>24</b>
General.....	24
Features .....	24
<b>Standard Station 70V/100V Speaker Output .....</b>	<b>25</b>
General.....	25
Field Wiring .....	25
<b>SmartSeries® Station 70V/100V Speaker Line Monitor .....</b>	<b>25</b>
General.....	25
Field Wiring .....	25
<b>Troubleshooting .....</b>	<b>28</b>

---

<b>Front Panel Removal .....</b>	<b>28</b>
<b>Front Panel PCBA Jumper Configuration .....</b>	<b>28</b>
<b>Front Panel Installation.....</b>	<b>31</b>
<i>Service and Spare Parts .....</i>	<i>31</i>
<i>Specifications .....</i>	<i>32</i>
<b>Power Requirements.....</b>	<b>32</b>
<b>Handset .....</b>	<b>32</b>
<b>Handset Amplifier .....</b>	<b>32</b>
<b>Speaker Amplifier .....</b>	<b>33</b>
<b>Enclosure Specifications.....</b>	<b>33</b>
<b>VLC Option Specifications.....</b>	<b>33</b>
<b>All-Call Option Specifications.....</b>	<b>33</b>
<b>RTU Option Specifications.....</b>	<b>33</b>
<b>70V/100V Speaker Output Option Specifications.....</b>	<b>34</b>
<b>Environmental.....</b>	<b>34</b>
<i>Approvals .....</i>	<i>34</i>



# Industrial Communication System

## Zone 2/22 Weatherproof

### Page/Party® Station

## Confidentiality Notice

This manual is provided solely as an installation, operation, and maintenance guide and contains sensitive business and technical information that is confidential and proprietary to GAI-Tronics. GAI-Tronics retains all intellectual property and other rights in or to the information contained herein, and such information may only be used in connection with the operation of your GAI-Tronics product or system. This manual may not be disclosed in any form, in whole or in part, directly or indirectly, to any third party.

## General Information

### Product Overview

The GAI-Tronics ICS (Industrial Communication System) Page/Party® station is a component of a modular industrial communication system. All stations are wired in parallel and additional stations can be added to the system at any time.

The standard configuration of the ICS Zone 2/22 Weatherproof Page/Party® station is an outdoor, multi-party, handset/speaker amplifier station using ac power. A number of options are available to add to station capabilities (see the Features and Options sections).

The ICS Zone 2/22 Weatherproof Page/Party® station is compatible with existing GAI-Tronics 700 series Page/Party® systems. ICS Zone 2/22 Weatherproof Page/Party® stations can replace or be added to existing Page/Party® systems.

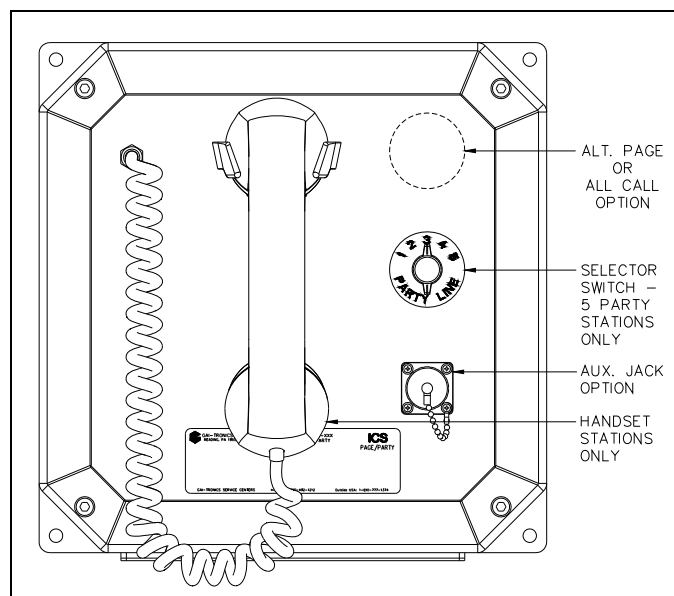

Figure 1. ICS Zone 2/22 Weatherproof Station Exterior Front Panel with all options

## Features

- one-way page announcements over system speakers
- high efficiency (>80%) Class D paging amplifier provides up to 30 watts of speaker output to an 8-ohm load
- full-duplex party line communication on five party lines
- universal ac power supply with power factor correction
- field upgradeable options
- black carbon-loaded, glass-reinforced polyester enclosure

## Options

- single party line
- speaker amplifier only (no handset)
- alternate page destination
- All-Call
- auxiliary jack for headset operation
- hazardous area approvals
- PVC or Hytrel handset cords in 6-, 15-, or 25-foot lengths
- conformal coating for PCBA
- 24 V dc power
- VLC (Volume Level Control) technology for alternate page volume
- SmartSeries® technology featuring ALS (Ambient Level Sensing) and available remote monitoring
- EPL (emergency party line)
- 70V/100V speaker output
- RTU (Remote Terminal Unit) operation

## Installation

### Important Safety Instructions

This equipment is suitable for use in Zone 2/22 hazardous areas OR non-hazardous locations only. Combinations of equipment in your system are subject to investigation by the local Authority Having Jurisdiction at the time of installation.

- **Read, follow, and retain instructions**—All safety and operating instructions should be read and followed before operating the unit. Retain instructions for future reference.
- **Heed warnings**—Adhere to all warnings on the unit and in the operating instructions.
- **Attachments**—Attachments not recommended by the product manufacturer should not be used, as they may cause hazards. Maximum system cable length is not to exceed two miles.
- **Servicing**—Do not attempt to service this unit by yourself. Opening or removing covers may expose you to dangerous voltage or other hazards. Refer all servicing to qualified service personnel.

**⚠ WARNING ⚠** —**POTENTIAL ELECTROSTATIC CHARGING HAZARD**—Model 10401-201 Headset and 10416-103 Extension Cord should be used in Group IIB or Group IIA areas only.

Capacitance values of 140 pF to 580 pF were measured on the external metallic unearthed components of this equipment. As such, special care must be taken in installation location and environment to address this hazard. See EN TR50404, “Electrostatics—Code of practice for avoidance of hazards due to static electricity” for additional information regarding proper installation and potential hazards.

**⚠ WARNING ⚠** —**EXPLOSION HAZARD**—Do not disconnect equipment unless power has been removed or the area is known to be non-hazardous. Avertissement—Risque d’explosion—Avant de débrancher l’équipement, couper le courant ou assurer que le secteur est su pour n’être pas hasardeux.

**⚠ WARNING ⚠** —**24 V dc systems:** Under NO condition should this equipment be operated from a battery charger without the batteries connected.

In 24 V dc systems, most chargers have an unloaded output of 35 to 45 volts that can quickly damage the equipment designed for nominal 24 volts. The maximum battery voltage should never exceed the maximum specified input voltage.

## Front Panel Removal

1. Remove the four screws from the front panel.
2. Turn the front panel to the right.

Keep all wiring and ribbon cables connected. The front panel and back box interiors are now exposed (see [Figure 2](#)).

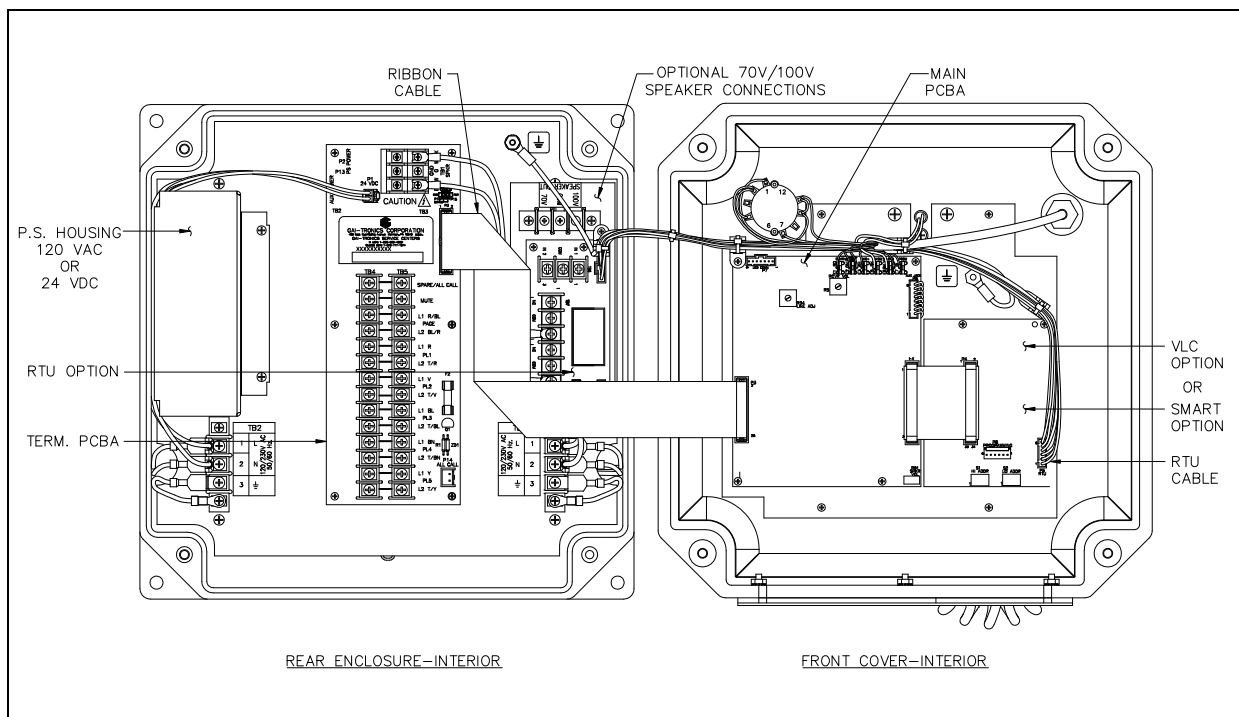

Figure 2. ICS Zone 2/22 Weatherproof Page/Party® Station Interior View (AC Version shown)

## Cable Entries

- The ICS Weatherproof Page/Party® Stations are not supplied with conduit or cable openings.
- Bottom entry is recommended to prevent moisture from dripping onto the terminals. Top entry is not recommended (see Figure 3).
- There must be a minimum of ½ inch (13 mm) of material between entry holes.
- The station can be supplied either with or without a stainless-steel gland plate, located on the bottom of the rear enclosure.
- Ensure any unused openings are sealed with proper fittings per local standards.
- All metric cable entry devices and blanking elements shall be certified for Zone 2/22 applications with an IP66 rating, suitable for conditions of use and correctly installed.
- Use field wiring suitable for the ambient temperature.

### Stations without a gland plate:

1. Remove the front panel.
2. Drill or punch entry openings in the rear section of the enclosure (see Figure 3).

### Stations with a gland plate:

1. Remove the gland plate from the bottom of the rear enclosure.
2. Drill or punch entry openings in the rear section of the enclosure (see Figure 3).
3. Upon reinstalling the gland plate, torque the #6-32 nuts to 10–12 in·lb (1.13–1.36 N·m).

## Enclosure Installation

The suggested mounting height for all station enclosures is 48 inches (1219 mm) to the center of the bottom mounting holes of the enclosure (see Figure 3).

Mount the enclosure with 5/16-inch (M6) hardware through the four 0.31-inch (8 mm) diameter holes located on the mounting flanges.

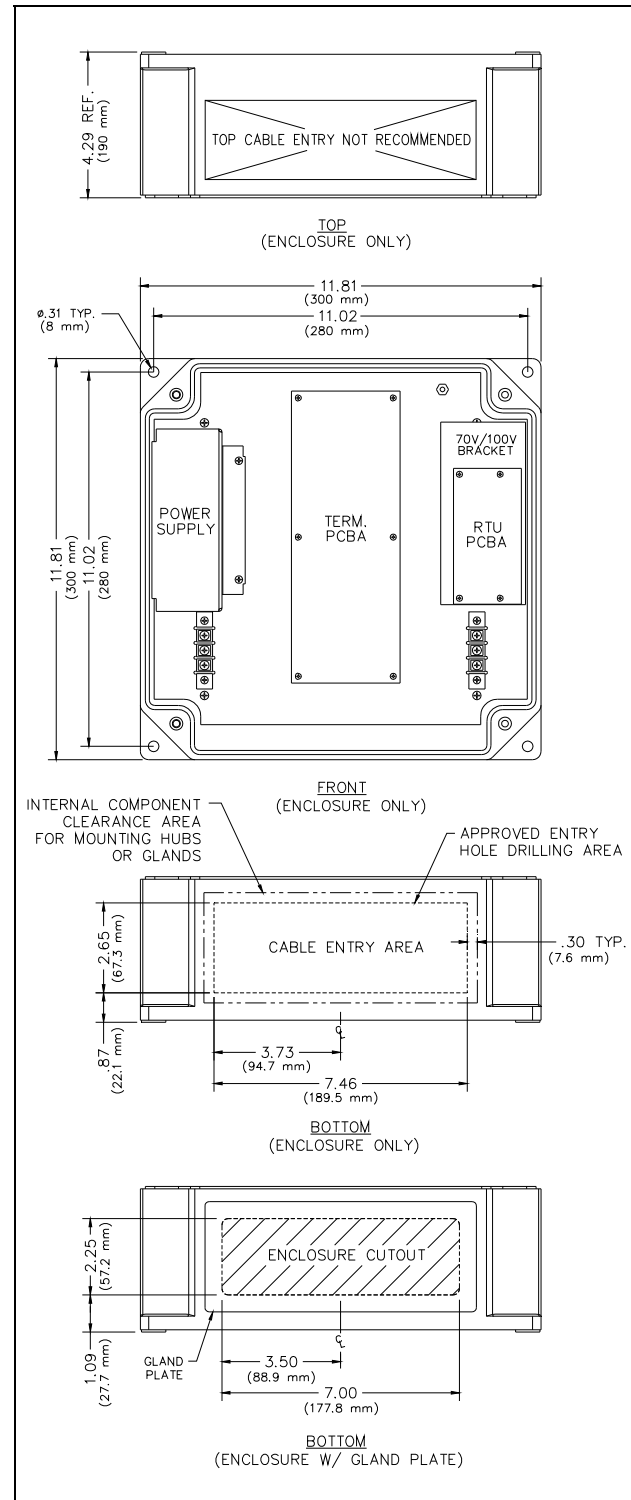

Figure 3. Suggested Cable Entry Locations

## Field Wiring

The ICS Page/Party® Station provides terminal blocks for field wiring. Two sets of terminals are provided for each connection of the system cable for daisy-chain wiring. The terminal blocks on the termination PCBA are labeled to coincide with the color coding used on GAI-Tronics No. 60029 series multi-party cable or No. 60038 series single party cable (see Figure 4).

1. Attach #6 ring lugs to the power conductors of the No 60029 series or No. 60038 series system cable.
2. Attach #6 spade lugs to all the remaining conductors of the system cable.
3. Attach the wires to the terminal blocks.

**NOTE:** See Figure 16 for the dc terminal locations in the DC Power Option section.

4. Torque the terminal block screws to 8 to 10 lb-in (0.90 to 1.13 N·m).

Paging audio may induce feedback in certain circumstances. Muting the speakers of two or more local stations during a page, referred to as *mutual muting*, can eliminate these feedback problems. If paging audio induces feedback:

5. Mute the speakers of the affected stations by connecting the spare orange wire between the stations to terminal block TB4-2 or TB5-2.

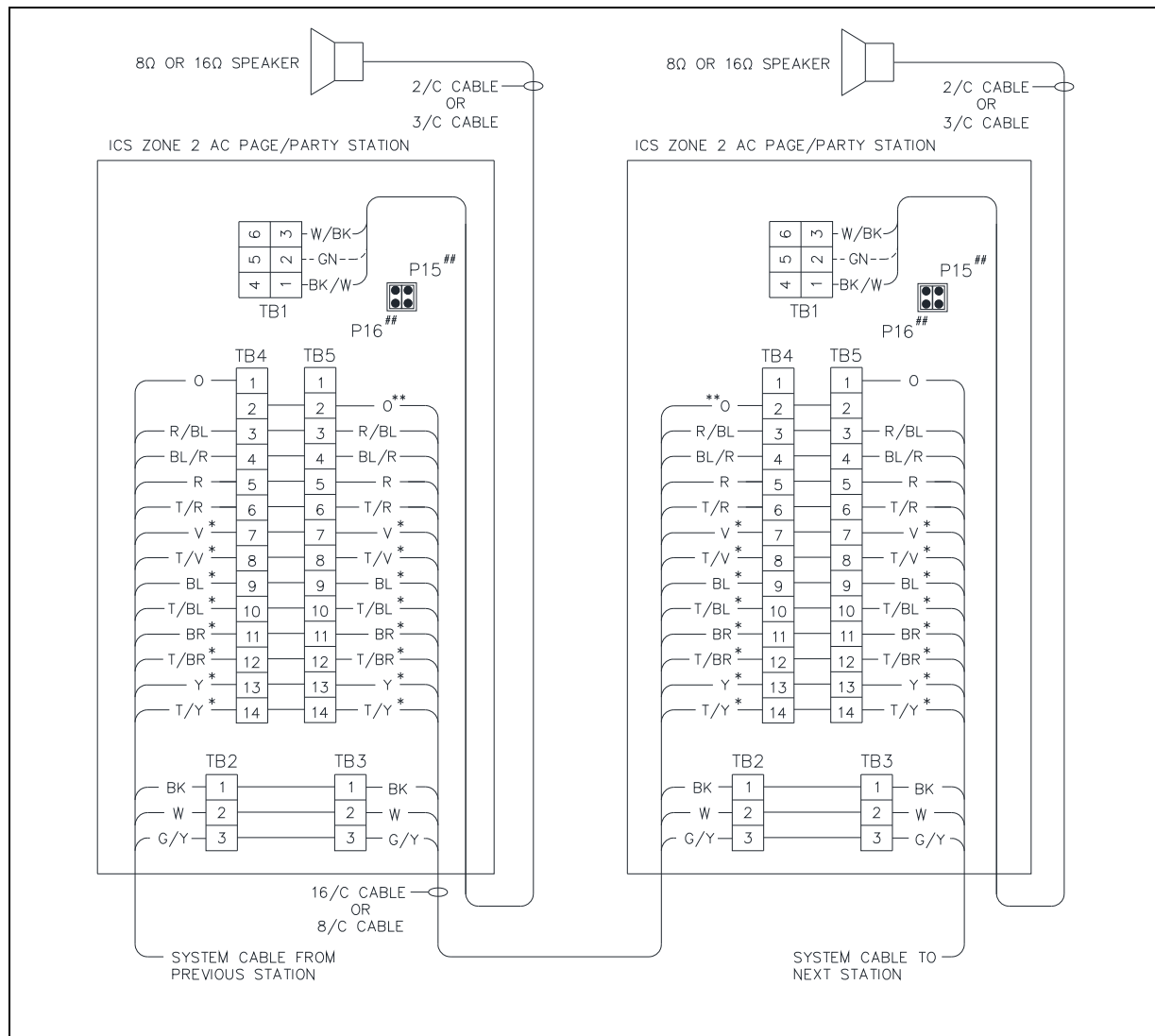

Figure 4. Typical Page/Party® ICS Station Wiring Diagram



# Speaker Impedance Configuration

Configure jumpers P15 and P16 for 8-ohm or 16-ohm speaker impedance (see Figure 5).

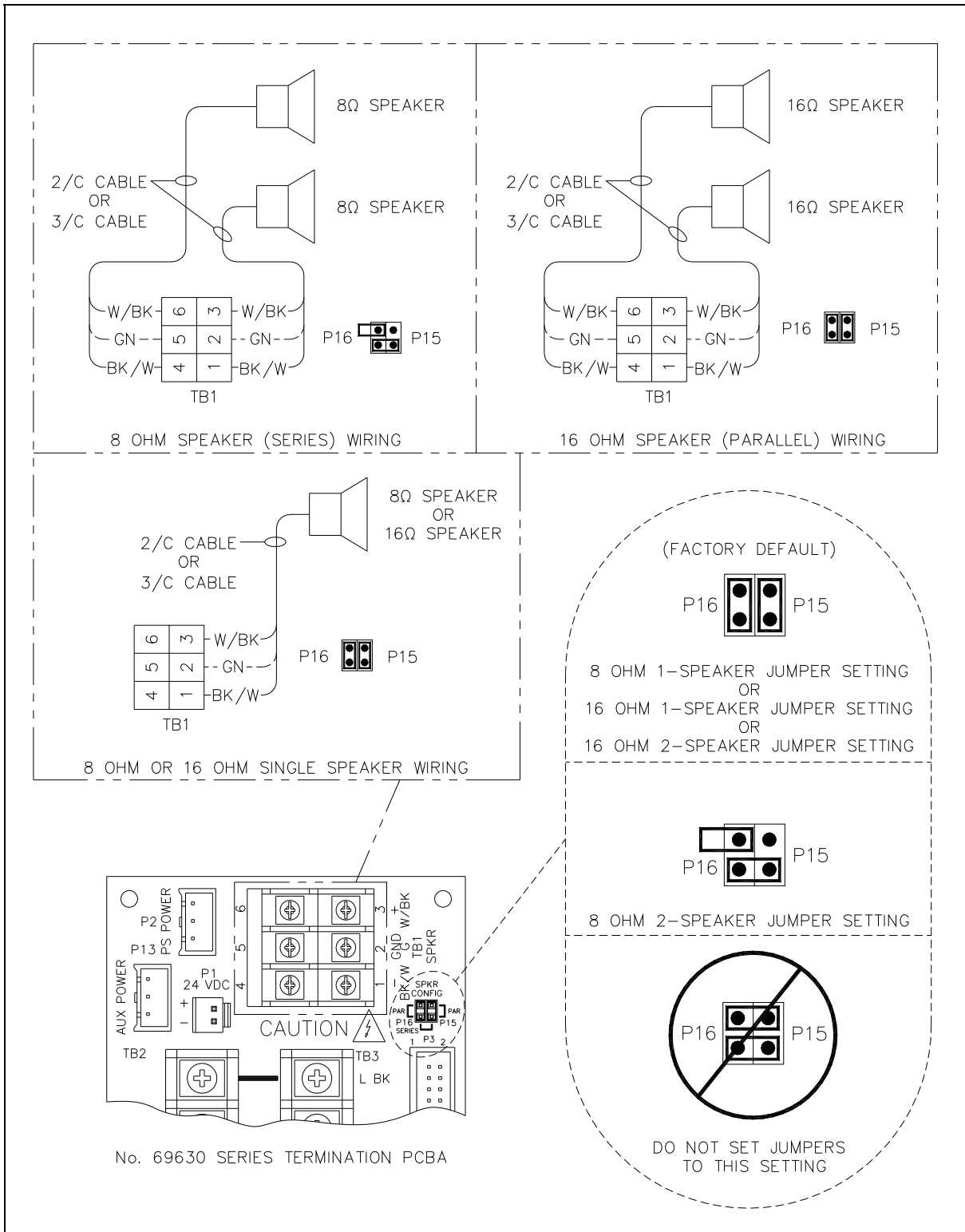

Figure 5. Jumper Configuration for 8-ohm or 16-ohm Speaker Impedance



## Speaker Mute



The station can mute the speaker amplifier during page operation to eliminate feedback. Adjust jumper P11, if necessary, to mute the local speaker when paging from that station (see [Figure 6](#)).

- P11 in the **EN** position (default) mutes the speaker during page activation.
- P11 in the **DIS** position allows broadcast to the speaker during paging.

## Speaker Gain

P9 sets the maximum speaker output level (see [Figure 6](#)).

- P9 in the **HI** position (default) represents a 30-watt maximum output.
- P9 in the **LO** position represents a 2-watt maximum output.

 **WARNING**  —Maximum output power may exceed rated speaker wattage resulting in speaker damage.

## Level Adjustments

### Transmit Level

Use the transmit-level potentiometer, R34, to adjust the signal level from the handset or optional auxiliary headset microphone to the page or party lines (see [Figure 6](#)).

### Receiver Volume

Use the receiver volume potentiometer, R5, to adjust the signal level to the handset receiver from the page or party lines (see [Figure 6](#)). This does not adjust the signal level to the optional auxiliary headset.

### Speaker Volume

Use the speaker volume potentiometer, R91, to adjust the signal level to the speaker from the page line (see [Figure 6](#)). The default setting is 4 watts for an 8-ohm speaker and 2 watts for a 16-ohm speaker.



1. Turn the speaker volume potentiometer, R91, (on the main PCBA) fully counterclockwise (see [Figure 6](#)).
2. Listen for a single beep from the speaker indicating the speaker amplifier is in the minimum level adjustment mode.

*If the page line is in use immediately after the beep tone is heard:* use the page signal as the reference to adjust the speaker volume level.

*If the page line is inactive following the beep tone:* a continuous tone is activated to make the minimum level adjustment. All page line activity is ignored until completion of the adjustment once the tone is activated. Use the test tone as a reference to adjust the speaker amplifier output level to the desired volume.

3. Adjust the speaker volume potentiometer, R91, to the desired output.

The test tone automatically shuts off 5 seconds after the last adjustment.

 **WARNING**  —Maximum output power may exceed rated speaker wattage resulting in speaker damage.

## Front Panel Installation

After all wiring, cable connections, and configuration have been completed:

1. Place the front cover on the rear enclosure.  
Do not to pinch any cables.
2. Secure the front cover using the four screws and washers provided.
3. Torque the screws to 50 in·lb (5.65 N·m).

## Operation

For paging and subsequent party line conversation:

1. Lift the handset or connect the optional headset
2. Select a free party line using the five-position rotary selector switch (if equipped).
3. Press the handset pressbar or headset page switch.
4. Page the desired individual, designating the party line that the individual should respond on.
5. Place the handset back on hook or disconnect the headset after the conversation is complete or after paging if no party line conversation is necessary.

To respond to a page:

1. Approach the nearest ICS Page/Party® station.
2. Select the appropriate party line.
3. Lift the handset or connect a headset.

Full-duplex communication can take place on the party line without broadcasting over the speakers.

4. Place the handset back on hook or disconnect the headset after the conversation is complete.

### NOTES:

- The ICS Page/Party® station incorporates a noise-canceling microphone to reduce transmitted ambient noise. This requires the user to place their mouth as close to the microphone as possible.
- For stations with an auxiliary jack, the Model 10401-201 Headset with the Model 10416-103 Extension Cord allows the user to be hands-free and mobile while maintaining communication. The handset microphone is disabled when connected.
- Stations with the alternate page destination option can select additional programmed page zones using the alternate page selector switch. The alternate page destinations must be software configured in the central control cabinet of a GAI-Tronics ADVANCE system.

## Options

The ICS SmartSeries®, VLC, and RTU station options can be factory or field installed. The dc power, 70V/100V speaker output, 70V/100V line monitoring, RF hookswitch options are factory installed.

### ICS SmartSeries®

#### General

The No. 69552 SmartSeries® PCBA (see Figure 7) adds microprocessor control to the ICS Page/Party® station, providing additional sensor and monitoring capabilities.

**NOTE:** SmartSeries® and VLC PCBAs cannot be installed in the same station.

#### Features

When used with or without ADVANCE head-end equipment:

- ALS (Ambient Level Sensing) circuitry—automatically changes the local speaker's paging volume in response to varying background noise
- off-hook timeout—prevents noise from being introduced to a party line by electronically placing the handset *on-hook* after 8 minutes
- page timeout—limits a single page broadcast to two minutes, freeing the page line for emergencies

When used with ADVANCE head-end equipment:

- station monitoring of key components (including handset, amplifier and local speaker)—provides fast notification of any faults
- ability to accept supervised contact closure inputs and provide a supervised relay output (requires RTU option)

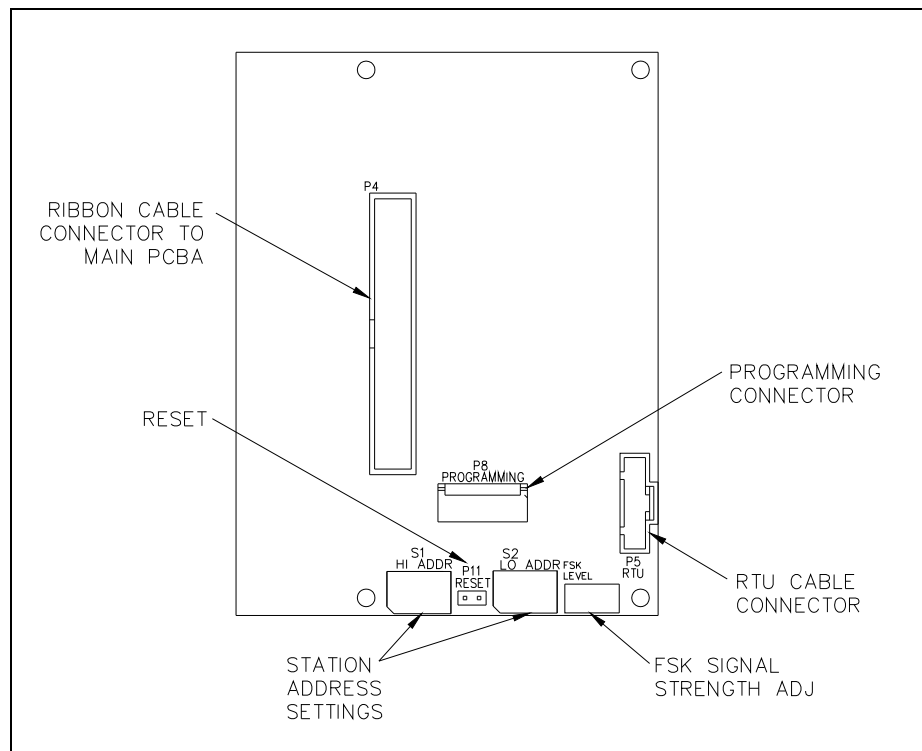

Figure 7. 69552 SmartSeries® PCBA

## Installation

### Front Panel Removal

1. Remove the four screws from the front panel.
2. Turn the front panel to the right.

Keep all wiring and ribbon cables connected. The front panel and back box interiors are now exposed (see [Figure 2](#)).

### SmartSeries® PCBA Installation

1. Remove power from the station.
2. Remove all jumpers on the main PCBA P4 connector (see [Figure 2](#)).
3. Align the SmartSeries® PCBA with the four mounting holes to the right of the main PCBA with the edge of the SmartSeries® board under the main PCBA.
4. Secure the SmartSeries® PCBA with the four screws provided.
5. Install the provided 34-pin ribbon cable from P4 of main PCBA to P4 of SmartSeries® PCBA.
6. Apply the included upgrade sticker to the power supply housing.
7. Reapply power to the station.

## Configuration

### Station Address

All SmartSeries® stations in an ADVANCE system must be given a unique address using the hexadecimal switches, S1 (Hi Address) and S2 (Lo Address) for the SmartSeries® option to function properly (see [Figure 7](#)).

- Each switch contains 16 settings, labeled 0–F. A small arrow on each switch indicates the setting.
- The station address is determined by the high address setting followed by the low address setting.  
For example, to assign an address of 05, the high station address switch, S1, is set to 0 and the low address switch, S2, is set to 5.
- Valid address settings are 05 to FE.
- Record the address assigned to each station in the system.

Set the address to 04 (default) if the SmartSeries® PCBA is installed in a system without an ADVANCE head end.

### ALS Minimum Level

The ALS minimum level is the lowest speaker output level that the station will maintain. The factory default setting for minimum level is 4.0 watts nominal into an 8-ohm load. To set the ALS minimum level:



1. Turn the speaker volume potentiometer, R91, (on the main PCBA) fully counterclockwise (see [Figure 6](#)).
2. Listen for a single beep from the speaker indicating the speaker amplifier is in the Minimum Level Adjustment mode.

*If the page line is in use immediately after the beep tone is heard:* use the page signal as the reference to adjust the speaker volume minimum level.

*If the page line is inactive following the beep tone:* a continuous tone is activated to make the minimum level adjustment. All page line activity is ignored until completion of the adjustment once the tone activates. Use the test tone as a reference to adjust the speaker amplifier output level to the desired volume.

3. Adjust the speaker volume potentiometer, R91, to the desired output.

The test tone automatically shuts off 5 seconds after the last adjustment.

 **WARNING**  —Maximum output power may exceed rated speaker wattage resulting in speaker damage.

### **ALS Offset Level**

The ALS offset level allows the output of the speaker amplifier to maintain a set difference or *offset* between the ambient noise level and the speaker output level. To set the ALS offset level:

1. Turn the speaker volume potentiometer, R91, (on the main PCBA) fully clockwise (see [Figure 6](#)).
2. Listen for two beep tones indicating that the station is in the offset adjustment mode.

*If the page line is in use immediately after hearing the two beep tones:* use the page signal to make the offset level adjustment.

*If the page line is inactive immediately following the beep tones:* a continuous tone activates to make the offset level adjustment. All page line activity is ignored until completion of the adjustment once the tone activates. Use the test tone as a reference to adjust the speaker amplifier offset level to the desired volume.

3. Adjust the speaker volume potentiometer, R91, to the desired offset level.

**NOTE:** This adjustment should be made under maximum ambient noise level. The ALS offset level must always be set higher than the ALS minimum level setting.

### **SmartSeries® VLC Level**

When activated, the VLC overrides the ALS minimum level setting allowing the speaker volume to change to a preset level during an emergency page. To adjust the VLC Level:

1. Force the station into the VLC mode by executing a page from a station programmed by the MCU to activate the VLC function.
2. During the page, turn the speaker volume potentiometer, R91, (on the main PCBA) fully counterclockwise (see [Figure 6](#)).
3. Listen for two beep tones through the page speaker that indicate the VLC adjustment mode is activated.
4. After the two beep tones, turn the speaker volume potentiometer, R91, to the desired speaker level using the live paging signal to adjust the level.

The station automatically exits the VLC adjustment mode and reverts to normal operation 5 seconds after the last potentiometer adjustment.

**NOTE:** The system must be equipped with an ADVANCE head end to activate the VLC function.

### Speaker Impedance Supervision

Speaker impedance supervision enables an ICS station to supervise the connected speaker line for changes in the speaker line impedance.

- The station must be calibrated for the impedance of the attached speaker(s) to perform this function.
- A station that has never been calibrated will report a speaker fault within 15 minutes of being configured for this feature in the ADVANCE system.
- Stations can be calibrated either *locally* at the station or *remotely* by a system command from the ADVANCE head end. See the ADVANCE System Programming Manual for instructions on performing *remote* calibration.

#### To perform a *local* calibration:

1. Configure the station for speaker impedance supervision.
2. Set the station's address to **0x02**.
3. Wait until you hear a single-beep tone at the attached speaker. This should occur within 20 seconds.

The single beep tone indicates that a successful calibration was performed. A double-beep tone indicates that the station attempted to calibrate but was unsuccessful (the attached impedance is out-of-range). If no tone is heard, the station may not be configured for speaker impedance supervision or there is an open connection to the speaker.

4. Set the address back to its original value to resume normal station operation with the new calibration value after hearing the single beep tone.

**NOTE:** Jumper P9 on the main PCBA must be in the HI (default) position if this feature is used.

### FSK Signal Gain

The FSK signal gain potentiometer, R13, adjusts the FSK transmit signal strength. This setting is factory configured and must not be adjusted by the installer.

### Front Panel Installation

After all wiring, cable connections, and configuration have been completed:

1. Place the front cover on the rear enclosure.  
Do not to pinch any cables.
2. Secure the front cover using the four screws and washers provided.
3. Torque the screws to 50 in·lb (5.65 N·m).

### Operation

#### Paging with ADVANCE Head End

Paging and party line operation with the ICS SmartSeries® option is similar to standard station operation with the following differences:

- A steady *page-confirmation* tone will be heard in the handset/headset earpiece when the handset pressbar or the headset page switch is pressed.
- A *page pre-announcement* tone, if programmed, will sound when the page-confirmation tone ends, and the operator can make a page.
- A *busy* tone heard in the handset/headset earpiece indicates that the system is busy and the page is denied.



---

**Paging without ADVANCE Head End**

Paging and party line operation is the same as standard station operation (see the Operation section).

**Station Time-out Features**

The ICS SmartSeries® option supports a page *duration limit* that sets the maximum duration of each page.

- A page is terminated if the page is still active when the page duration limit is reached.
- The page duration limit is fixed at 2 minutes when used without an ADVANCE head end.

The ICS SmartSeries® option supports an *off-hook limit* that sets the maximum duration that the station may be kept off hook.

- The station is placed electrically on hook if the off-hook limit is reached.
- The handset must be physically placed on hook momentarily to reset the timeout condition.
- The off-hook limit is fixed at 8 minutes when used without an ADVANCE head end.

**All-Call Paging Utilizing a Merge/Isolate Cabinet**

M/I (Merge/Isolate) cabinets contain switching relays that are energized by a control signal from Page/Party® stations. The relays merge (connect together) the page lines of multiple Page/Party® systems when energized. This allows voice pages to be broadcast from all of the systems connected to the M/I cabinet. ICS handset stations with the All-Call feature contain a push-button switch on the front panel to activate an M/I cabinet (see Figure 8).

**SmartSeries® Dual Page All-Call Utilizing ADVANCE Head End**

A monitored dual page zone can be utilized for the All-Call push button for stations with the *Dual Page All-Call* option. The Dual Page All-Call option must be software configured in the central control cabinet of a GAI-Tronics ADVANCE system (see Figure 8).

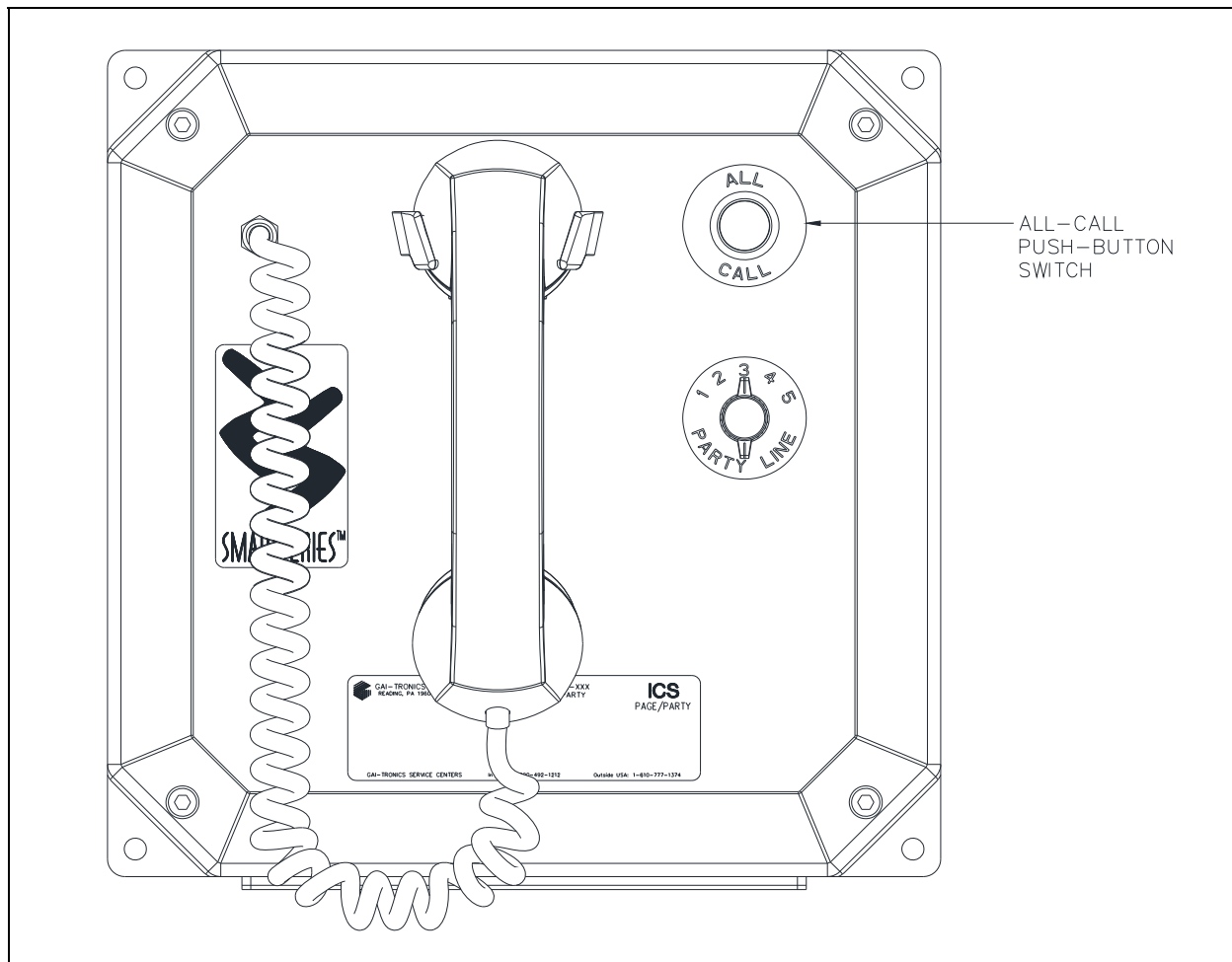

Figure 8. All-Call Selector Switch Location

### EPL (Emergency Party Line)

The EPL option enables ICS SmartSeries® Stations connected to an ADVANCE control cabinet to automatically report the following information when the handset is taken off-hook:

- zone number
- station address
- party line (one or two)

**Paging with Alternate Page Destination Utilizing ADVANCE Head End**

Additional programmed page zones can be used with the alternate page selector switch on stations with the alternate page destination option (see Figure 9). The alternate page destinations must be software configured in the central control cabinet of a GAI-Tronics ADVANCE system.

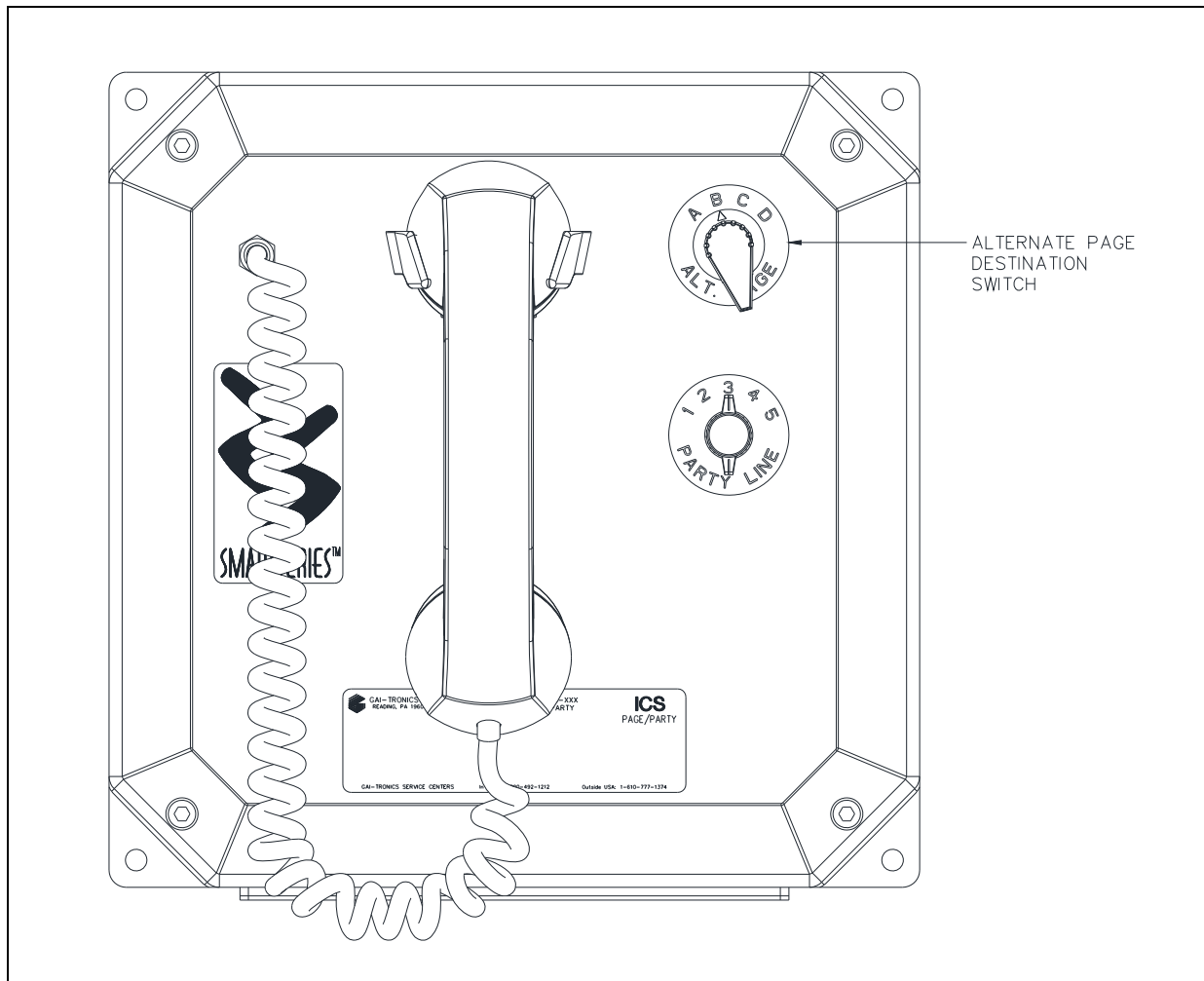

Figure 9. Alternate Page Selection Switch Location

## VLC

### General

The No. 69553 VLC (Volume Level Control) PCBA (see Figure 10) adds the capability to remotely control the local speaker volume level. A remote device transmits a 50 kHz signal over the page line when VLC is activated. The station detects the 50 kHz signal and switches to an alternate speaker volume setting.

**NOTE:** VLC and SmartSeries® options cannot be used in the same station.

### Features

- provides an *alternate* speaker volume setting that is activated by receiving a 50 kHz signal on the page line
- allows office or crew quarters speakers to be muted until a high priority message or alarm is broadcast
- prevents local handset paging during emergency situations
- enables outdoor speaker volume to be reduced at night
- adds the ability to provide a relay output (requires RTU option)

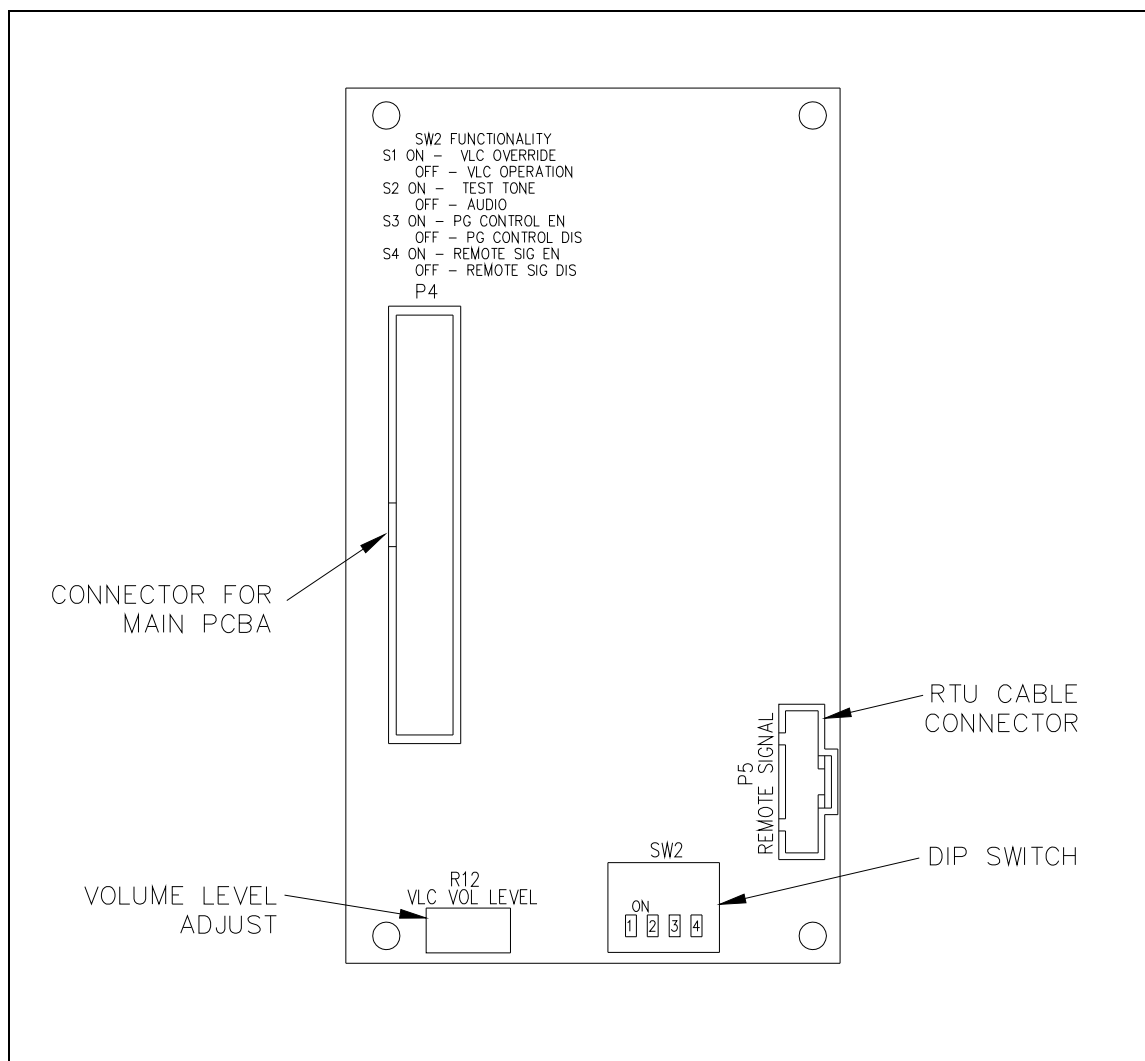

Figure 10. 69553 Series VLC PCBA

## Installation

### Front Panel Removal

1. Remove the four screws from the front panel.
2. Turn the front panel to the right.

Keep all wiring and ribbon cables connected. The front panel and back box interiors are now exposed (see [Figure 2](#)).

### VLC PCBA Installation

1. Remove power from the station.
2. Remove all jumpers on the main PCBA P4 connector (see [Figure 2](#)).
3. Align the VLC PCBA with the four mounting holes to the right of the main PCBA board.
4. Secure the VLC PCBA with the four screws provided.
5. Install the provided 34-pin ribbon cable from P4 of main PCBA to P4 of VLC PCBA.
6. Apply the included upgrade sticker to the power supply housing.
7. Reapply power to the station.

## Configuration

### 50 kHz Alignment

The 50 kHz alignment potentiometer, R5, adjusts the receiver's frequency for VLC operation. It is set at the factory and must not be adjusted by the installer.

### Speaker Mute

Jumper P26 (see [Figure 10](#)) enables muting the speaker audio during VLC or normal operation:

- Audio is muted during a VLC broadcast with jumper P26 in the **50kHz** position.
- Audio is muted during normal operation with jumper P26 in the **NORM** position.
- Remove jumper P26 to operate the unit without the muting feature.

### Audio Alignment

To set the normal speaker output level (see [Figure 10](#)):

1. Set DIP switch SW2-1 to the off position.
2. Set DIP switch SW2-2 to the on position to enable a reference test tone.
3. Adjust the speaker volume potentiometer, R91, (on the main PCBA) to the desired audio level (see [Figure 6](#)).
4. Turn the speaker volume potentiometer, R91, fully counterclockwise to mute the audio.

**NOTE:** The adjustment cannot be made if LED2 on the VLC PCBA is on; indicating the system VLC tone is present.

To set the VLC controlled speaker output level (see [Figure 10](#)):

1. Set SW2-1 to the on position.
2. Set SW2-2 to the on position to enable a reference test tone.
3. Adjust R12 on the VLC PCBA to the desired audio level.
4. Turn R12 fully counterclockwise to mute the audio.
5. Set SW2-1 and SW2-2 to the off position to return to normal system operation.

#### **Page Disable Control**

Set SW2-3 (see [Figure 10](#)) to the on position to disable local paging when the system VLC tone is present.

#### **Remote Output Switching (Available with RTU Only)**

Set SW2-4 (see [Figure 10](#)) to the on position to activate the RTU relay when the system VLC tone is present.

#### **Front Panel Installation**

After all wiring, cable connections, and configuration have been completed:

1. Place the front cover on the rear enclosure.  
Do not to pinch any cables.
2. Secure the front cover using the four screws and washers provided.
3. Torque the screws to 50 in·lb (5.65 N·m).

## **RTU**

### **General**

The No. 69627 RTU (Remote Terminal Unit) PCBA (see [Figure 11](#)) adds remotely controlled dry relay contacts to an ICS Page/Party® station equipped with either a VLC PCBA or a SmartSeries® PCBA in conjunction with an ADVANCE head end. Two supervised inputs are also available when used with the SmartSeries® PCBA in conjunction with ADVANCE head end.

The No. 69628 RTU and SmartSeries® 70V/100V Speaker Line Monitor PCBA (see [Figure 12](#)) adds a single remotely controlled dry relay contact or a single supervised input to an ICS Page/Party® station equipped with a SmartSeries® PCBA in conjunction with an ADVANCE head end.

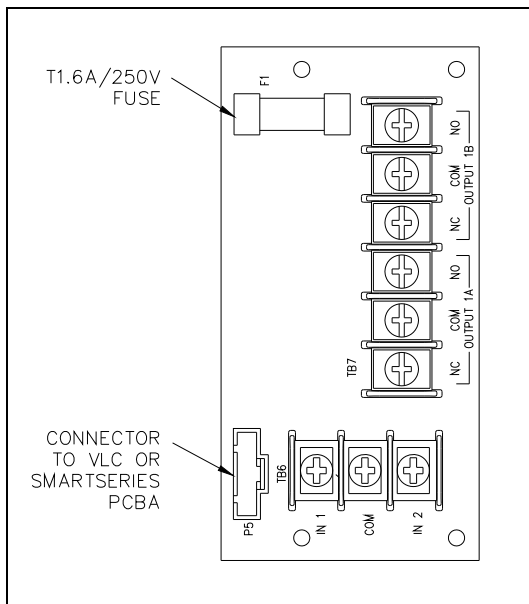
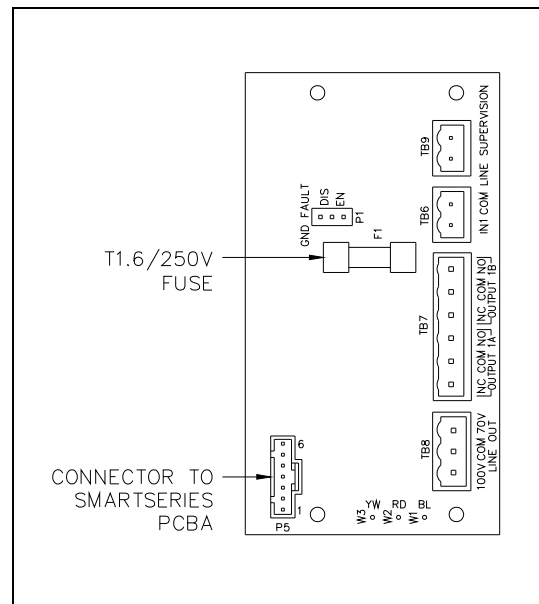

Figure 11. 69627 Series RTU PCBA

Figure 12. 69628 Series RTU & SmartSeries®  
70V/100V Speaker Line Monitor PCBA

## Features

### With SmartSeries® PCBA and ADVANCE Head End

- two dry-contact input circuits (input cable supervision is optional) for 69627 Series RTU PCBA
- one dry-contact input circuit (input cable supervision is optional) for 69628 Series RTU & SmartSeries® 70V/100V Speaker Line Monitor PCBA
- input status is monitored to trigger an action in the ADVANCE head end
- double pole, Form C relay contact (output cable supervision is available)
- one fuse-protected relay contact

### With SmartSeries® PCBA and Dual Page All-Call with ADVANCE Head End

- one dry-contact input circuit
- input status is monitored to trigger action in the ADVANCE head end
- double pole, Form C relay contact (output cable supervision is available)
- one fuse-protected relay contact

### With VLC PCBA

- double-pole, Form C relay contacts
- one fuse-protected relay contact

## Installation

### Front Panel Removal

1. Remove the four screws from the front panel.
2. Turn the front panel to the right.

Keep all wiring and ribbon cables connected. The front panel and back box interiors are now exposed (see [Figure 2](#)).

**RTU PCBA Installation**

1. Remove power from the station.
2. Install the four provided standoffs onto the four studs located adjacent to the power supply.
3. Align the RTU PCBA with the four standoffs with TB7 oriented toward the termination PCBA (see Figure 2).
4. Secure the RTU PCBA with the four screws provided.
5. Install the provided 6-conductor harness from P5 on the SmartSeries® or VLC PCBA to P5 on the RTU PCBA.
6. Apply the included upgrade sticker to the power supply housing.
7. Reapply power to the station.

**Field Wiring**

The RTU PCBA provides terminal blocks for field wiring the I/O circuits. Attach spade lugs to the wires before connection to the terminal blocks.

OUTPUT 1A and OUTPUT 1B are activated by either the VLC or SmartSeries® PCBA. OUTPUT 1B is fused on the NO (normally open) contact with a T1.6-amp fuse.

**Non-supervised Output Wiring Configuration**

Figure 13. Non-supervised Output with the VLC or SmartSeries® Option



## Supervised Output Wiring Configurations with SmartSeries® Option

**⚠ WARNING ⚠** — Installation of this component shall be carried out by suitably trained personnel in accordance with the applicable code of practice concerning equipment and protective systems intended for use in potentially explosive atmospheres. This component must be in a suitable enclosure for the potentially explosive atmosphere. During normal operation at 230 V this component can support a temperature code of T4. This component shall be installed at a location acceptable to the authority having jurisdiction.

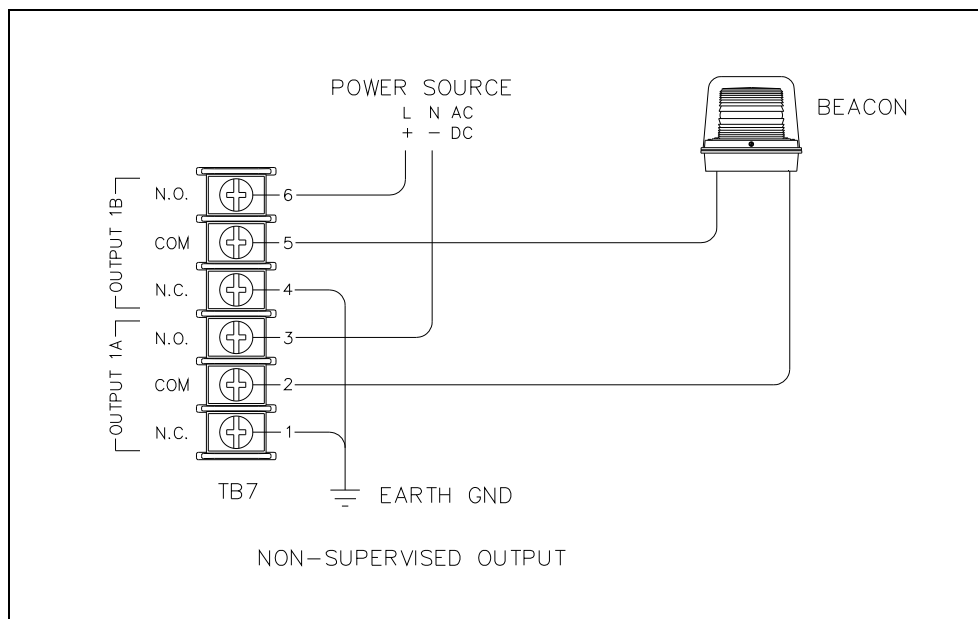
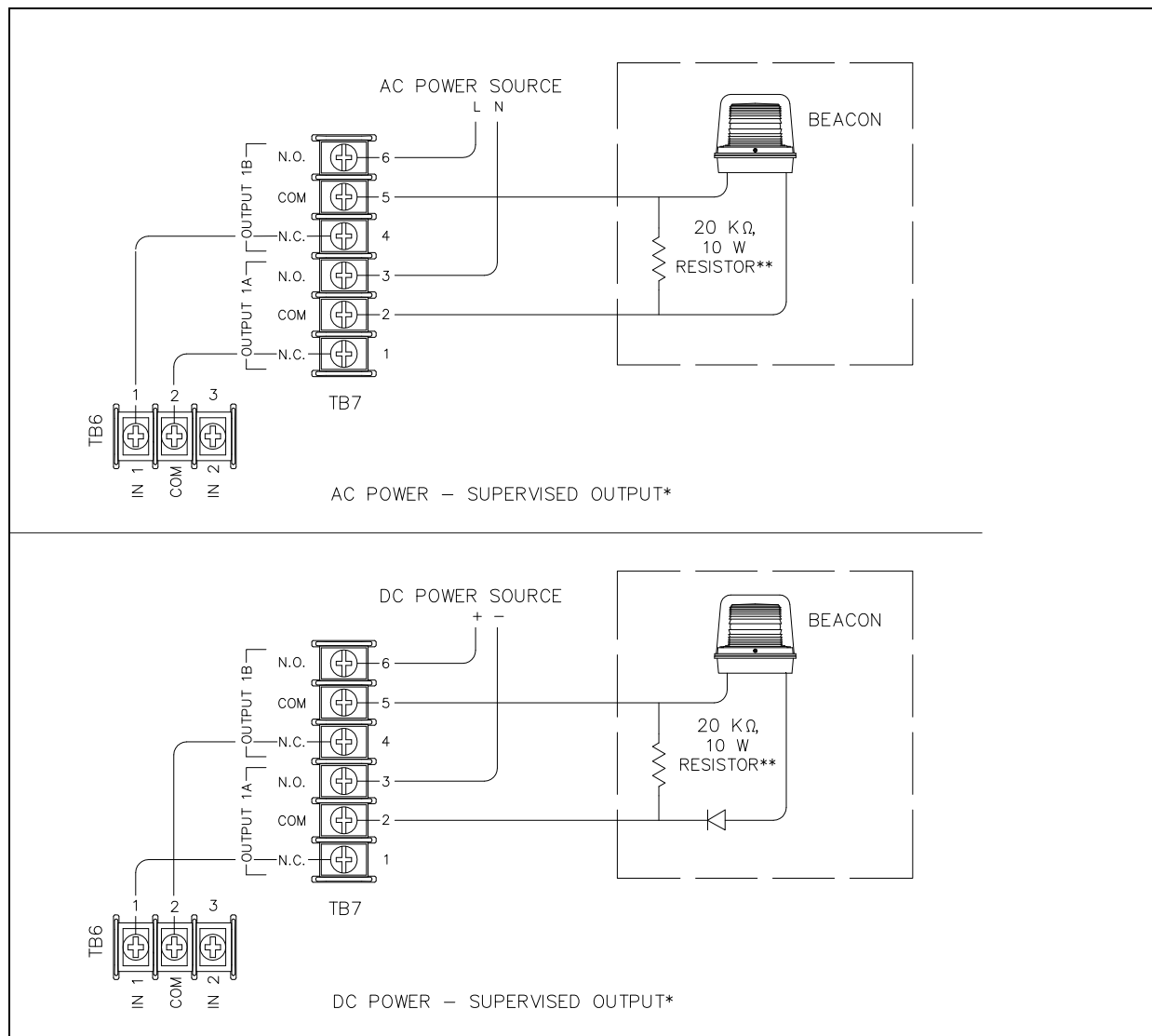

Figure 14. Supervised Output Wiring with SmartSeries® Option

**NOTES:**

\*Input one is used to monitor output one and is not available for other functions.

\*\*20-kilohm, 10-watt supervision resistor

Input 1 or 2 Wiring Configuration with the SmartSeries® Option

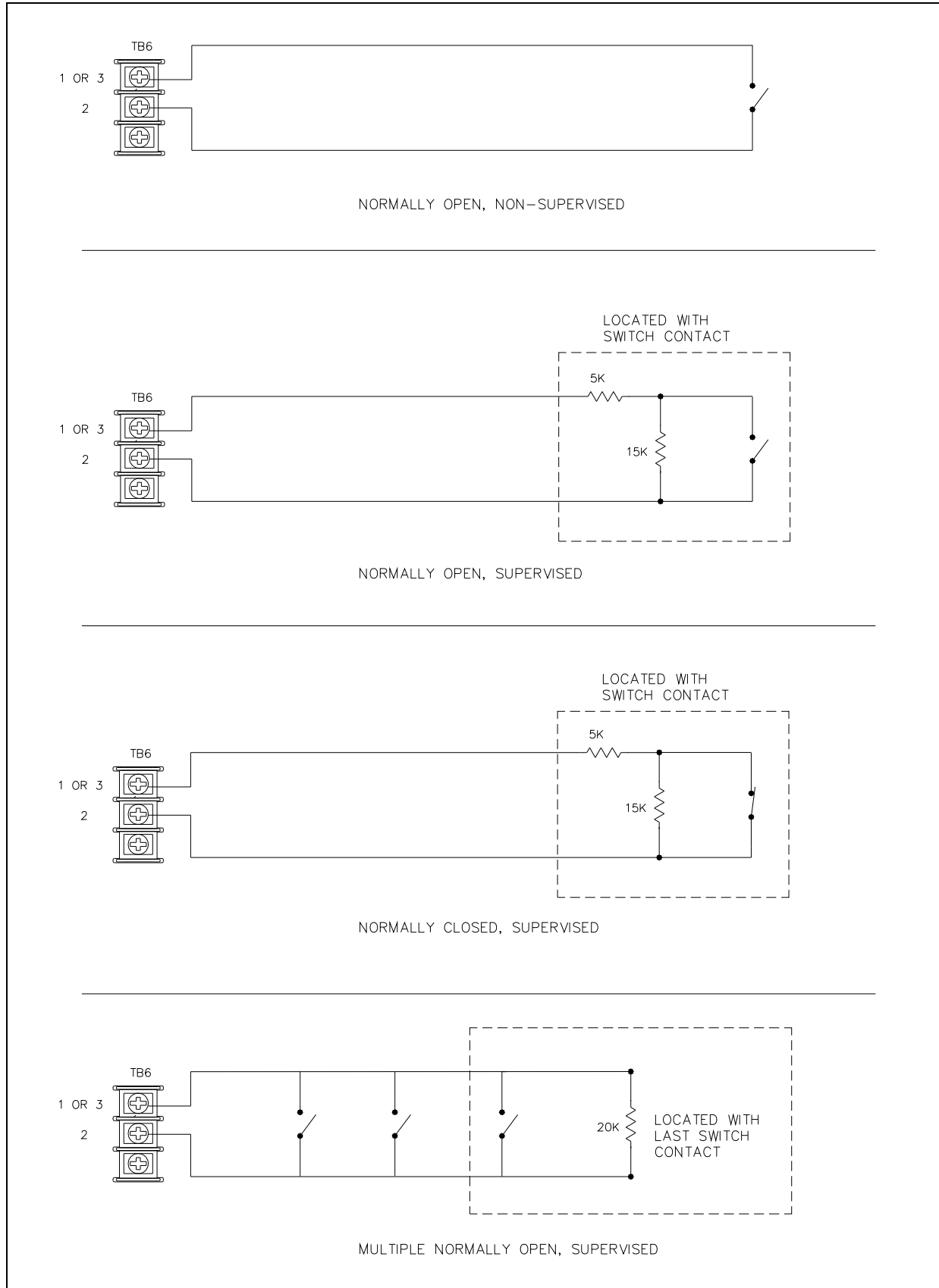

Figure 15. Input 1 or 2 Wiring Configuration with the SmartSeries® Option

## Front Panel Installation

After all wiring, cable connections, and configuration have been completed:

1. Place the front cover on the rear enclosure.  
Do not to pinch any cables.
2. Secure the front cover using the four screws and washers provided.
3. Torque the screws to 50 in·lb (5.65 N·m).

## DC Power Option

### General

The dc power option adds the capability to utilize 24 V dc power to operate the station.

### Features

- 24 V dc  $\pm$ 20% power input
- simplified wiring scheme using main termination PCBA

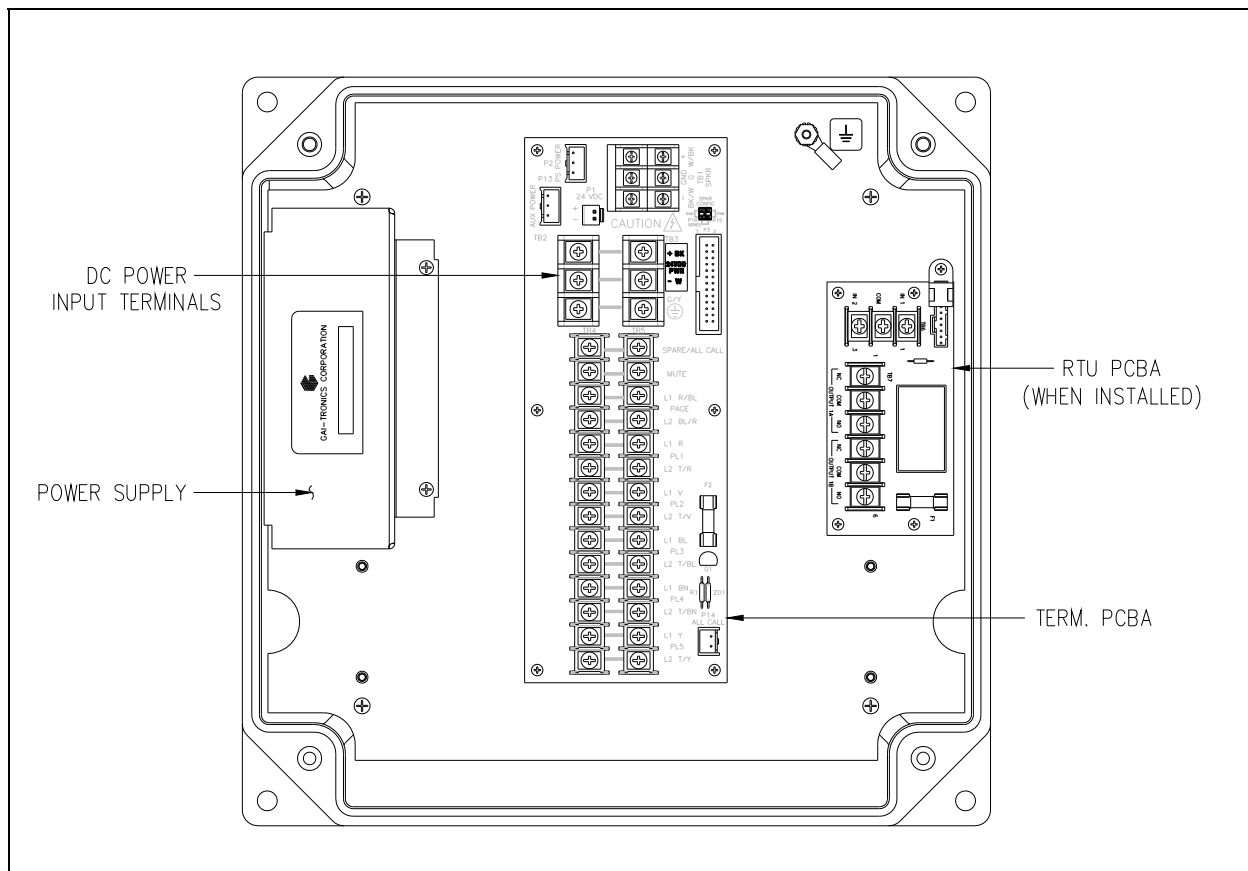

Figure 16. DC Option—Interior View

## Standard Station 70V/100V Speaker Output

### General

The 70V/100V speaker output assembly enables connection of multiple 70-volt or 100-volt speakers to a single ICS Page/Party® station. The speakers are wired in parallel to the station (see [Figure 17](#) and [Figure 19](#)).

### Field Wiring

- Connect 100 V speaker wires to terminal block TB8, terminals 100V and COM.
- Connect 70 V speaker wires to terminal block TB8, terminals 70V and COM.

## SmartSeries® Station 70V/100V Speaker Line Monitor

### General

The 70V/100V speaker line monitor assembly enables connection of multiple 70-volt or 100-volt speakers to a single ICS SmartSeries® Station. Speakers are wired in parallel to the station. The speaker line can be monitored by looping it back to the ICS SmartSeries® Station when used with an ADVANCE head-end cabinet (see [Figure 18](#) and [Figure 20](#)).

**NOTE:** SmartSeries® ALS and local speaker monitoring are not available when the 70V/100V speaker output option is installed and must be disabled for this station in the system configuration.

### Field Wiring

- Connect 100 V speaker wires to the plug for terminal block TB8, terminals 100V and COM.
- Connect 70 V speaker wires to the plug for terminal block TB8, terminals 70V and COM.

**NOTE:** Use of the 8/16-ohm speaker output or TB1 will affect maximum speaker power output.

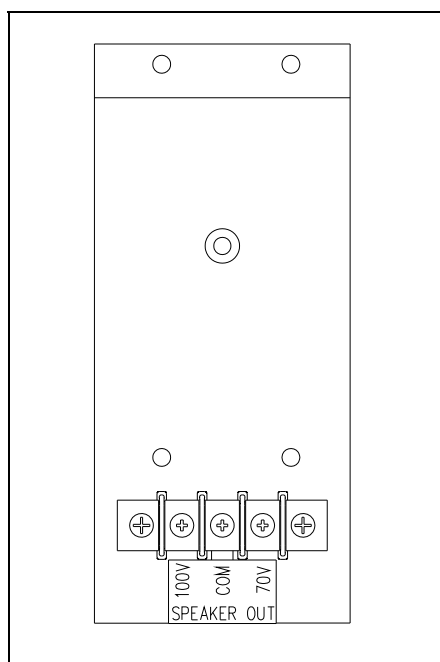

Figure 17. Standard Station 70V/100V Speaker Output Assembly

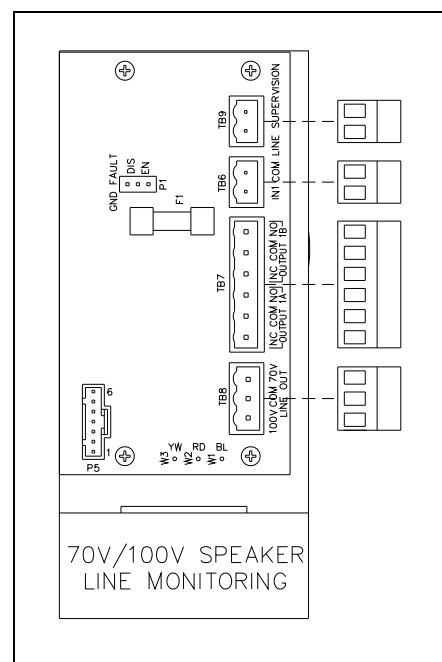

Figure 18. SmartSeries® Station 70V/100V Speaker Line Monitor Assembly

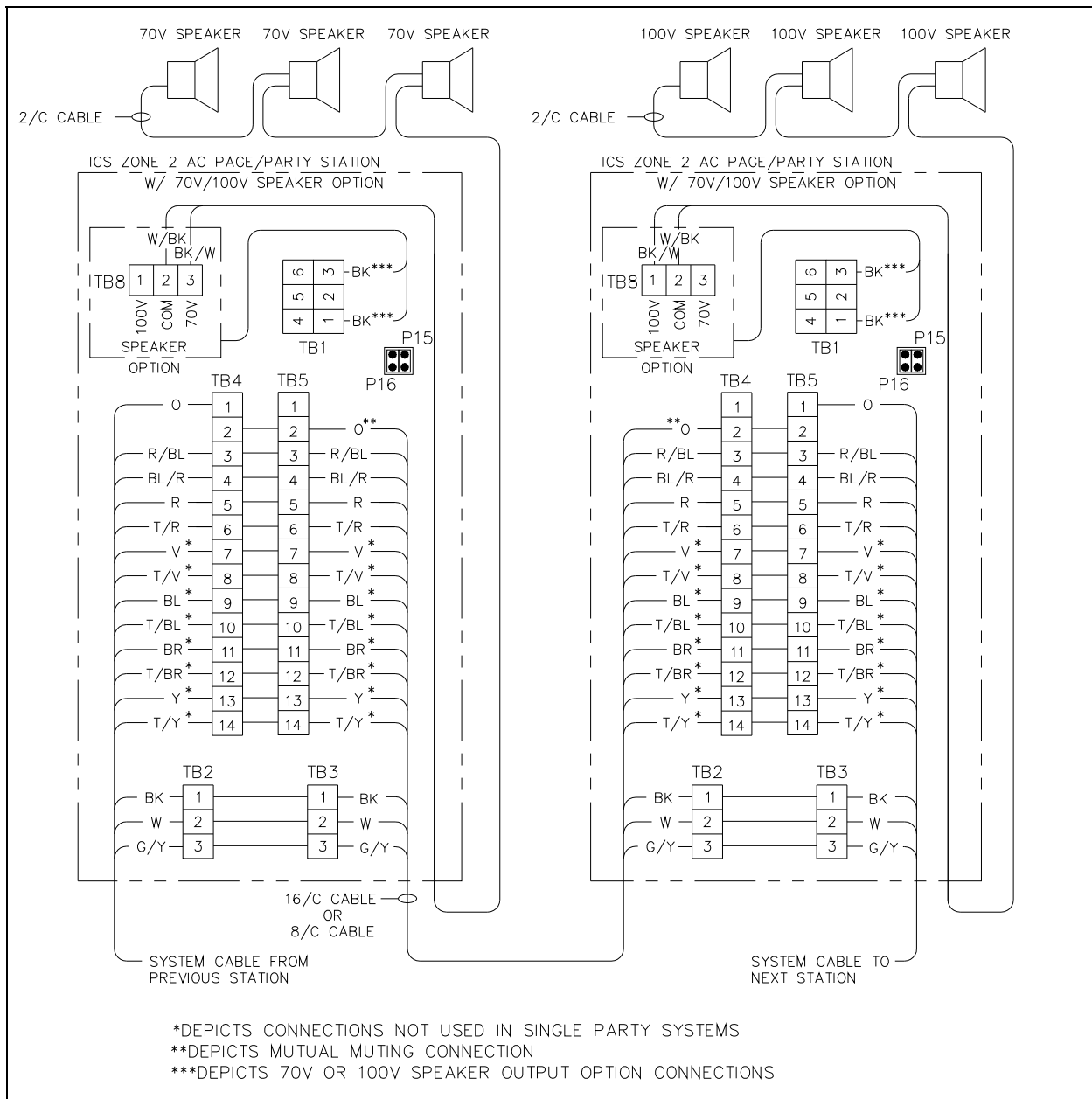

Figure 19. 70V / 100V Speaker Connections

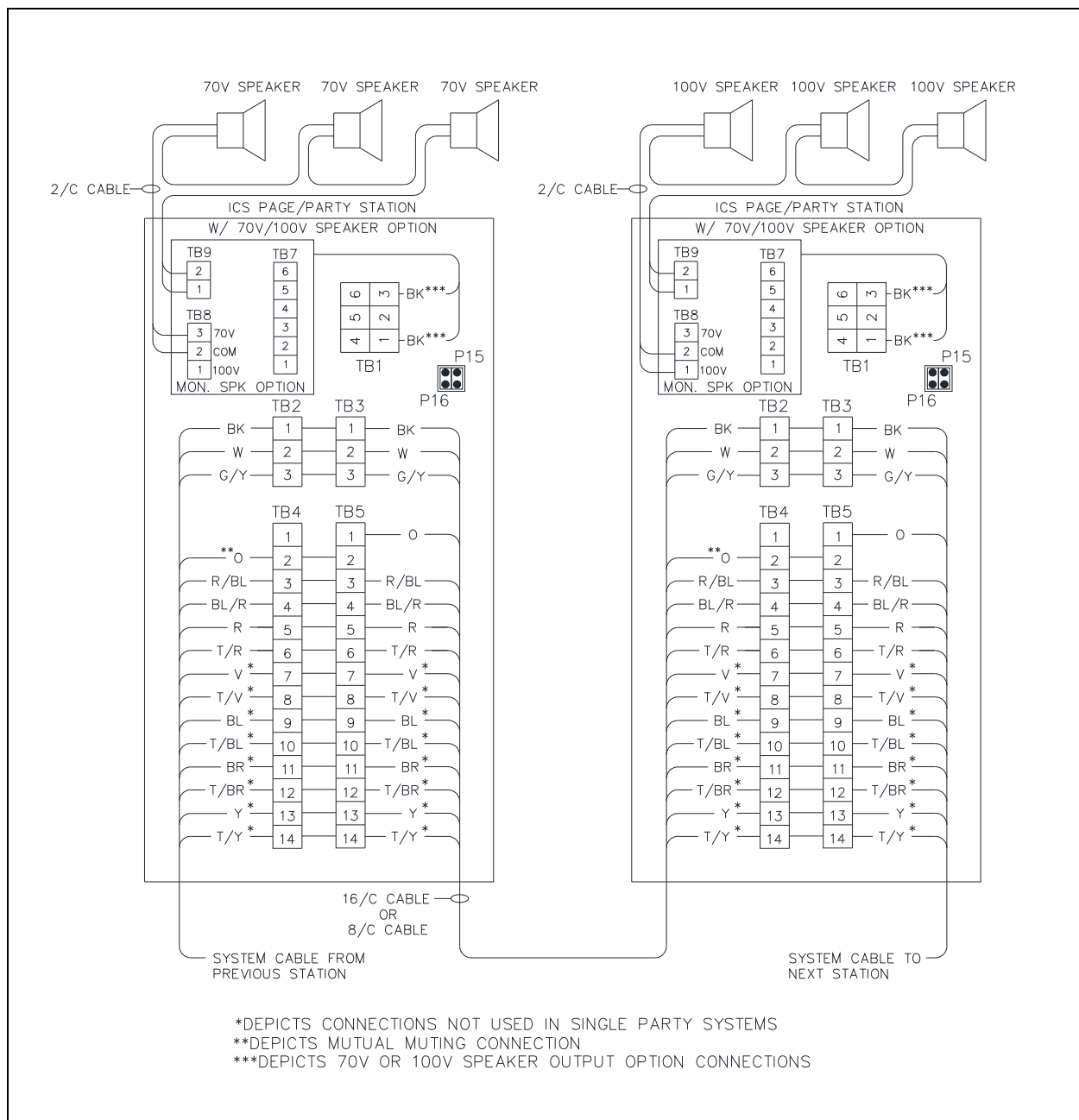

Figure 20. 70V/100V Monitored Speaker Connections

# Troubleshooting

## Front Panel Removal

1. Remove the four screws from the front panel.
4. Turn the front panel to the right.

Keep all wiring and ribbon cables connected. The front panel and back box interiors are now exposed (see [Figure 2](#)).

## Front Panel PCBA Jumper Configuration

The front panel PCBAs are protected by a universal shield. Most potentiometer adjustments and jumper settings can be made without removing the shield (see [Figure 21](#) for adjustment locations).

### P4 Standard Jumper Configuration:

ICS stations without options require the default installation of jumper P4 for proper operation (see [Figure 21](#)).

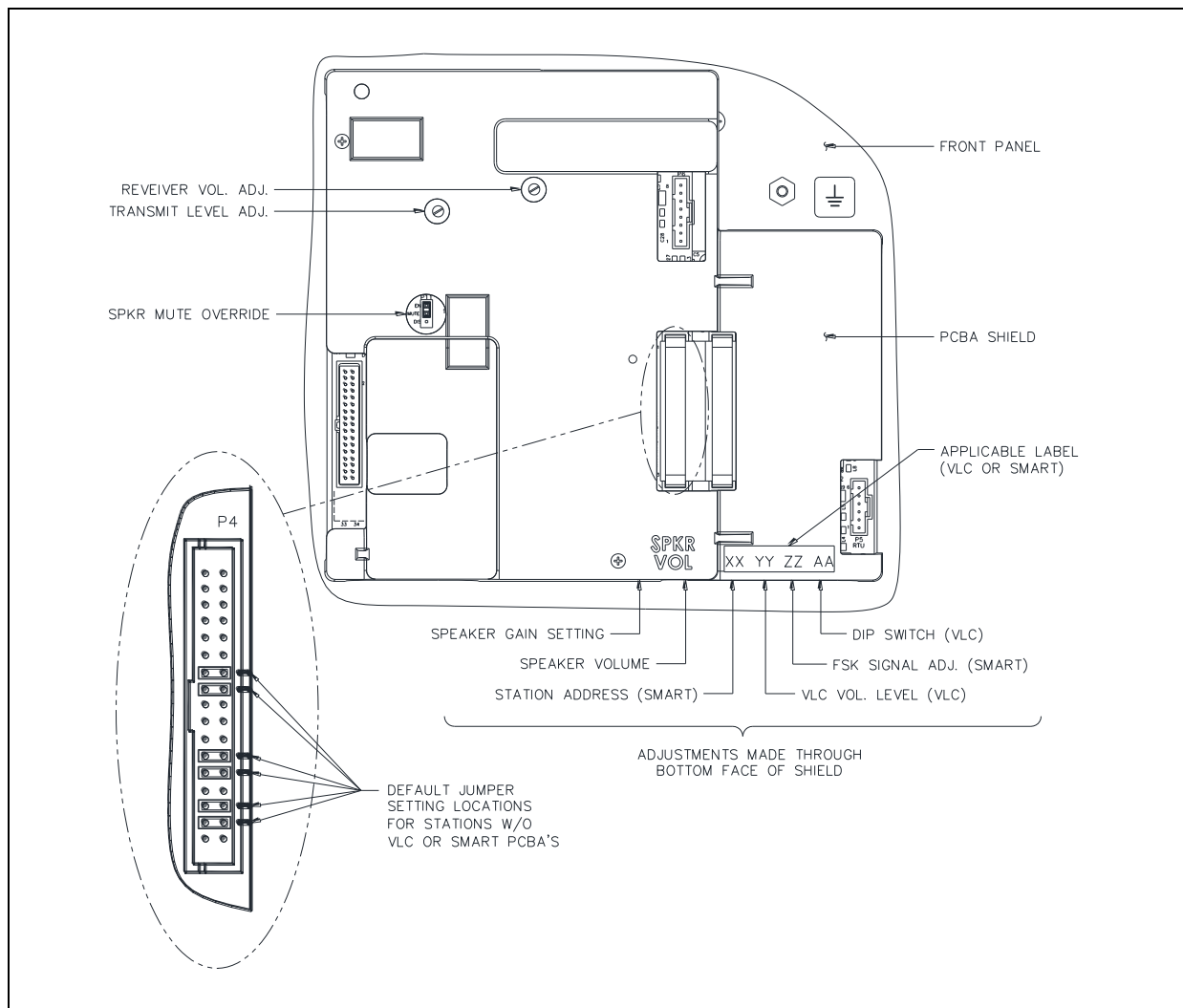

Figure 21. P4 Jumper Default Settings

The following tables are provided to aid qualified service personnel in troubleshooting problems with the ICS Page/Party® Station.

Table 1. General Troubleshooting

Problem	Potential Cause
station not functional	<ul style="list-style-type: none"> <li>• See the <u>Field Wiring</u> section for proper terminations.</li> <li>• Verify incoming supply voltage at TB2 or TB3 on the termination PCBA.</li> <li>• Verify regulated 24 V dc at P1 on the termination PCBA.</li> </ul> <p style="text-align: center;">⚠ <b>CAUTION</b> ⚠ —Supply voltage is present at P2.</p>
excessive hum or buzz during station operation	Inspect the Page/Party® lines for proper line terminations, shorts, and grounds.
crosstalk occurs between Page/Party® lines	<ul style="list-style-type: none"> <li>• Inspect the Page/Party® lines for proper line terminations, shorts, and grounds.</li> <li>• Inspect the party line connections for crossing of the cable pairs.</li> </ul>
feedback occurs during page	<ul style="list-style-type: none"> <li>• Check the location and orientation of the speakers in the area.</li> <li>• See the <u>Field Wiring</u> section, Step 4, mutual muting.</li> <li>• See the <u>Speaker Mute</u> section.</li> </ul>
squeal in handset receiver	<ul style="list-style-type: none"> <li>• Verify proper termination of the Page/Party® lines.</li> <li>• Verify the system line balance is connected.</li> </ul>
handset microphone audio is too low/loud	<ul style="list-style-type: none"> <li>• Disconnect the headset, if connected.</li> <li>• See the <u>Transmit Level</u> section.</li> <li>• Check jumper settings or cable connections at P4.</li> <li>• Verify proper termination of the Page/Party® lines.</li> <li>• Check handset connections.</li> <li>• Check for proper cable terminations between the termination and main PCBAs.</li> <li>• Check the operation of the hookswitch.</li> <li>• Replace the handset.</li> </ul>
handset receiver audio is too low/loud	<ul style="list-style-type: none"> <li>• See the <u>Receiver Volume</u> section.</li> <li>• Check the jumper settings or cable connections at P4.</li> <li>• Verify proper termination of the Page/Party® lines.</li> <li>• Check the handset connections.</li> <li>• Check for proper cable terminations between the termination and main PCBAs.</li> <li>• Check the operation of the hookswitch.</li> <li>• Replace the handset.</li> </ul>



Table 2. Troubleshooting Standard/VLC Configurations

Problem	Potential Cause
speaker volume too low/loud	<ul style="list-style-type: none"> <li>• see the <a href="#">Speaker Volume</a> section; for VLC, the <a href="#">Audio Alignment</a> section.</li> <li>• Verify P15 and P16 are in the correct position for the application.</li> <li>• Verify the speaker wiring configuration is correct.</li> <li>• Verify the nominal page line level is correct.</li> <li>• Replace the speaker or driver.</li> </ul>
cannot place a page	<ul style="list-style-type: none"> <li>• For VLC, see the <a href="#">Audio Alignment</a> and <a href="#">Page Disable Control</a> sections.</li> <li>• Check the handset connections.</li> <li>• Check for proper cable terminations between the termination and main PCBAs.</li> <li>• Check the jumper settings or cable connection at P4.</li> <li>• Replace the handset.</li> </ul>
RTU output not functional	<ul style="list-style-type: none"> <li>• Verify the VLC PCBA is installed and operational. See the <a href="#">Remote Output Switching (Available with RTU Only)</a> section.</li> <li>• Check fuse F1 on the RTU PCBA.</li> <li>• Check the cable connection at P5 on the RTU and VLC PCBAs.</li> <li>• Check the RTU terminal connections at TB7. See <a href="#">Figure 13</a>.</li> <li>• Check the operation of the connected device.</li> </ul>
RTU input not functional	Inputs are only available with the SmartSeries® option.

Table 3. Troubleshooting SmartSeries® Configurations

Problem	Potential Cause
speaker volume too low/loud	<ul style="list-style-type: none"> <li>• Refer to the <a href="#">ALS Minimum Level</a>, <a href="#">ALS Offset Level</a>, and <a href="#">SmartSeries® VLC Level</a> sections.</li> <li>• Check cable connection at P4.</li> <li>• Verify P15 and P16 are in the correct position for the application.</li> <li>• Verify the speaker wiring configuration is correct.</li> <li>• Verify the nominal page line level is correct.</li> <li>• Replace the speaker or driver.</li> </ul>
Page/Party® operation not functional	<ul style="list-style-type: none"> <li>• Refer to the <a href="#">Station Address</a> section.</li> <li>• Check cable connection at P4.</li> <li>• Check proper cable terminations between the termination and main PCBAs.</li> <li>• Verify proper termination of the Page/Party® lines.</li> </ul>
RTU output not functional	<ul style="list-style-type: none"> <li>• For supervised output, verify that no monitored output faults exist.</li> <li>• Check fuse F1 on the RTU PCBA.</li> <li>• Check the cable connection at P5 on the RTU and SmartSeries® PCBA.</li> <li>• Check the RTU terminal connections at TB6 and TB7. Refer to <a href="#">Figure 13</a> and <a href="#">Figure 14</a>.</li> <li>• Check for operation of the connected device.</li> </ul>
RTU input not functional	<ul style="list-style-type: none"> <li>• For supervised input, verify no monitored input faults exist.</li> <li>• Check the cable connection at P5 on the RTU and SmartSeries® PCBA.</li> <li>• Check the RTU terminal connections at TB6. Refer to <a href="#">Figure 15</a>.</li> <li>• Check operation of connected device.</li> </ul>

## Front Panel Installation

After all wiring, cable connections, and configuration have been completed:

1. Place the front cover on the rear enclosure.  
Do not to pinch any cables.
2. Secure the front cover using the four screws and washers provided.
3. Torque the screws to 50 in·lb (5.65 N·m).

## Service and Spare Parts

If the equipment requires service or spare parts, contact your regional service center for assistance. If service is required, an RA# (return authorization number) will be issued. Equipment should be shipped prepaid to GAI-Tronics with a return authorization number and a purchase order number. If the equipment is under warranty, repairs or a replacement will be made in accordance with GAI-Tronics' warranty policy. Please include a written explanation of all defects to assist our technicians in their troubleshooting efforts. Call 800-492-1212 inside the USA or 610-777-1374 outside the USA for help with identifying the regional service center closest to you.

# Specifications

## Power Requirements

### AC/DC Input

#### AC Power Supply

Input voltage ..... 120/230 V ac (nominal), 50/60 Hz

Power factor @ nominal 120 V ac ..... 0.60

#### DC Power Supply

Input voltage ..... 24 V dc +/-20%

#### Current/Power requirements (+/-10%)

<b>Power Consumed (8-ohm load)</b>	<b>24 V DC</b>	<b>120 V AC</b>	<b>230 V AC</b>
Idle	165 mA/4.0 W	90 mA/10.8 VA	80 mA/18.4 VA
4-watt output (default setting)	460 mA/11.0 W	160 mA/19.2 VA	120 mA/27.6 VA
12-watt output	900 mA/21.6 W	300 mA/36.0 VA	190 mA/43.7 VA
30-watt output	1.95 A/46.8 W	640 mA/76.8 VA	360 mA/82.8 VA
<b>Maximum Current Consumption (8-ohm load)</b>	<b>19.2 V DC</b>	<b>108 V AC</b>	<b>253 V AC</b>
30-watt output	2.44 A/46.8 W	700 mA/84.0 VA	390 mA/80.7 VA
70V/100V speaker output*	2.44 A/46.8 W	520 mA/46.5 VA	230 mA/61.0 VA

\*When 70V/100V speaker output assembly is installed

## Handset

Microphone ..... dynamic, noise-canceling

Receiver ..... dynamic, hearing aid compatible

Cord ..... retractile, 6-ft extended, PVC

Material ..... ABS

External control ..... push-to-page handset pressbar

## Handset Amplifier

Output level (compression controlled) ..... 1.5 V<sub>RMS</sub> nominal into 33-Ω load  
adjustable 0–2.1 V<sub>RMS</sub>

Frequency response ..... 250–6,500 Hz, +0/–3 dB ref. to 1 kHz

Distortion ..... <1.5% THD @ 1 kHz (below compression level)

Receiver level ..... 200 mV<sub>RMS</sub>, nominal  
adjustable 150–400 mV<sub>RMS</sub>

**Speaker Amplifier**

Maximum output:

8-ohm speaker*	30 W into 8-Ω load with 1.5 V <sub>RMS</sub> input page level adjustable to 30 W; default: 4 W @ 8 Ω
16-ohm speaker	15 W into 16-Ω load with 1.5 V <sub>RMS</sub> input page level adjustable to 15 W; default: 2 W @ 16 Ω
Frequency response	250–6,500 Hz, +0/–3 dB ref. to 1 kHz
Distortion	<1% THD @ 1 kHz to 24 W <3% THD @ 1 kHz to 30 W
Input impedance	50 kΩ 16 kΩ with SmartSeries® option
SmartSeries® offset level adjustment range	0 to 30 dB

\*See Figure 22 and Figure 23.

**Enclosure Specifications**

Construction/finish	black carbon-loaded, glass-reinforced polyester
Mounting	wall or column, four 0.31-in (8 mm) mounting holes
Termination connections	screw-type barriers terminal blocks
Dimensions	11.8 H × 11.8 W × 4.3 D in (300 × 300 × 109 mm)
External control	handset hookswitch and party line selector switch on multi-party stations
Shipping weight	15.0 lb (6.8 kg)
Net weight	14.0 lb (6.3 kg)

**VLC Option Specifications**

VLC minimum input level	50 mV <sub>RMS</sub>
VLC tolerance	50 kHz +/-4%

**All-Call Option Specifications**

All-Call control output	sink 50 mA maximum to circuit common pulled up to 24 V dc maximum
-------------------------	--

**RTU Option Specifications****Output Relay**

Maximum load current	8 A OUTPUT 1A (unfused) 1.6 A OUTPUT 1B (fused)
Maximum in-rush current	15 A
Maximum voltage	250 V ac

**RTU Input Control (with SmartSeries® Option)**

Switch type	NO (normally open) or NC (normally closed) dry contacts
End-of-line termination	20 kΩ, or 15 kΩ + 5.1 kΩ
Cable resistance	100 Ω maximum loop resistance
Contact closure resistance	1 kΩ maximum
Open fault detection	65 kΩ
Short fault detection	<200 Ω

### 70V/100V Speaker Output Option Specifications

Maximum output..... 24 W  
Nominal output voltage..... 70.7 V or 100 V

#### Environmental

Temperature range (operation and storage) ..... -22 °F to 158 °F (-30 °C to 70 °C)  
Humidity ..... 95% non-condensing  
Enclosure ..... IP 66

### Approvals

CE Mark

Certificate No.  
Notified Body ID No. 0539  
UL International DEMKO A/S  
Lyskear 8  
DL-2730 Herlev  
Denmark

DEMKO 10 ATEX 1010664x .....  $\text{Ex}$  II 3 G ic nA IIC T4 Gc and  $\text{Ex}$  II 3 D ic tb IIIC T135°C Dc  
CENELEC ... EN 60079-0:2012+A11:2013 EN 60079-11:2012 EN 60079-15:2010 EN 60079-31:2014  
IECEx UL 10.0038x ..... Ex ic nA IIC T4 Gc and Ex ic tb IIIC T135°C Dc  
IEC 60079-0:2011 Edition 6.0 IEC 60079-11:2011 Edition 6.0 IEC 60079-15:2010 Edition 4.0 EN  
60079-31:2013 Edition 2.0

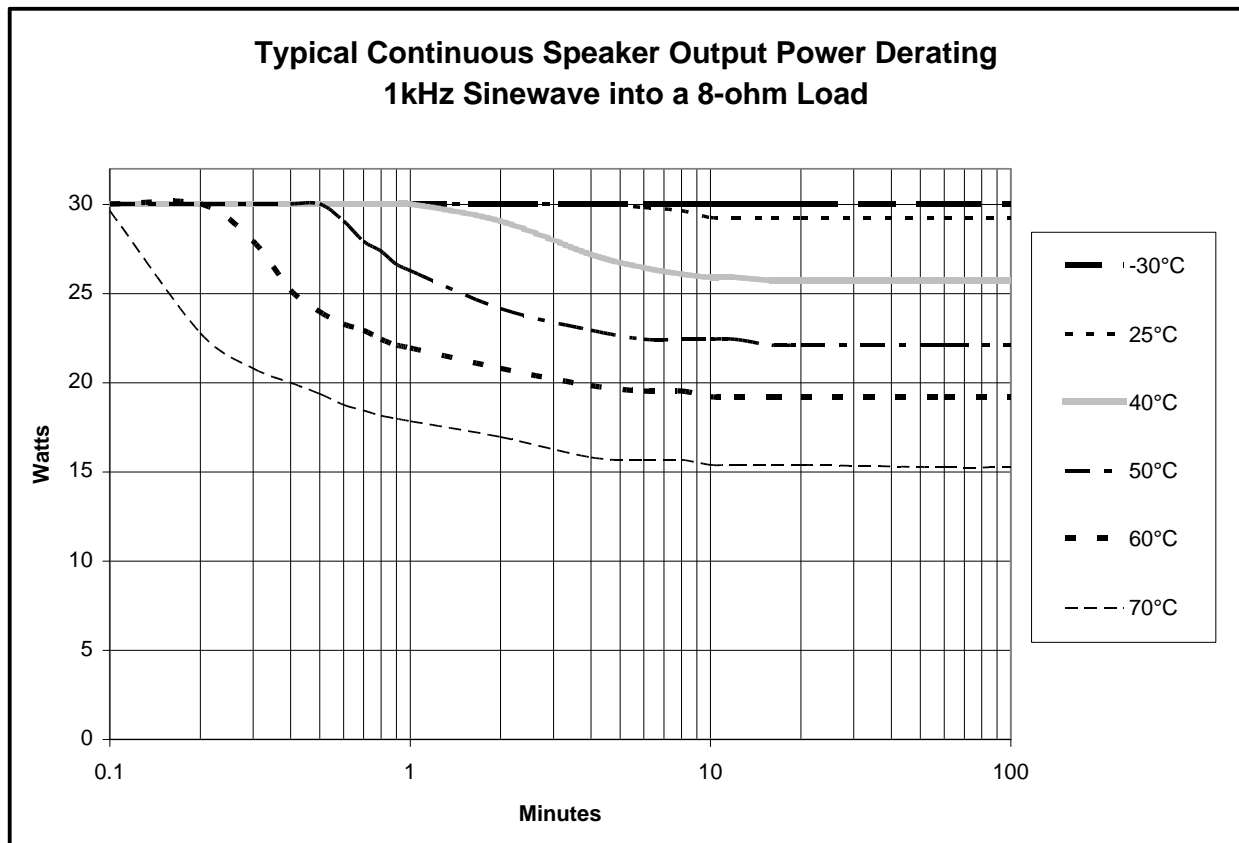

Figure 22. Typical Continuous Speaker Output Power Derating

1 kHz Sine Wave into an 8-ohm Load

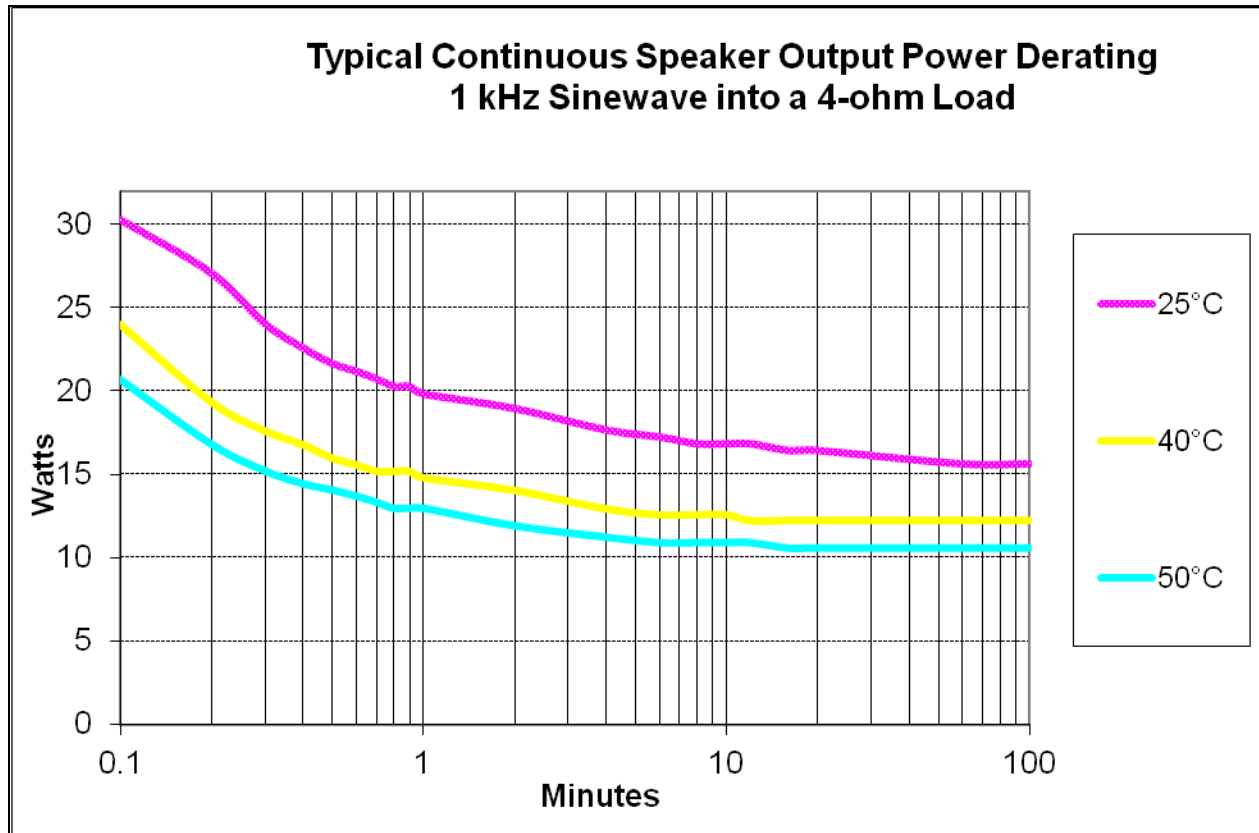

Figure 23. Typical Continuous Speaker Output Power Derating  
1 kHz Sine Wave into a 4-ohm Load

# Warranty

---

Equipment. GAI-Tronics warrants for a period of one (1) year from the date of shipment, that any GAI-Tronics equipment supplied hereunder shall be free of defects in material and workmanship, shall comply with the then-current product specifications and product literature, and if applicable, shall be fit for the purpose specified in the agreed-upon quotation or proposal document. If (a) Seller's goods prove to be defective in workmanship and/or material under normal and proper usage, or unfit for the purpose specified and agreed upon, and (b) Buyer's claim is made within the warranty period set forth above, Buyer may return such goods to GAI-Tronics' nearest depot repair facility, freight prepaid, at which time they will be repaired or replaced, at Seller's option, without charge to Buyer. Repair or replacement shall be Buyer's sole and exclusive remedy. The warranty period on any repaired or replacement equipment shall be the greater of the ninety (90) day repair warranty or one (1) year from the date the original equipment was shipped. In no event shall GAI-Tronics warranty obligations with respect to equipment exceed 100% of the total cost of the equipment supplied hereunder. Buyer may also be entitled to the manufacturer's warranty on any third-party goods supplied by GAI-Tronics hereunder. The applicability of any such third-party warranty will be determined by GAI-Tronics.

Services. Any services GAI-Tronics provides hereunder, whether directly or through subcontractors, shall be performed in accordance with the standard of care with which such services are normally provided in the industry. If the services fail to meet the applicable industry standard, GAI-Tronics will re-perform such services at no cost to buyer to correct said deficiency to Company's satisfaction provided any and all issues are identified prior to the demobilization of the Contractor's personnel from the work site. Re-performance of services shall be Buyer's sole and exclusive remedy, and in no event shall GAI-Tronics warranty obligations with respect to services exceed 100% of the total cost of the services provided hereunder.

Warranty Periods. Every claim by Buyer alleging a defect in the goods and/or services provided hereunder shall be deemed waived unless such claim is made in writing within the applicable warranty periods as set forth above. Provided, however, that if the defect complained of is latent and not discoverable within the above warranty periods, every claim arising on account of such latent defect shall be deemed waived unless it is made in writing within a reasonable time after such latent defect is or should have been discovered by Buyer.

Limitations / Exclusions. The warranties herein shall not apply to, and GAI-Tronics shall not be responsible for, any damage to the goods or failure of the services supplied hereunder, to the extent caused by Buyer's neglect, failure to follow operational and maintenance procedures provided with the equipment, or the use of technicians not specifically authorized by GAI-Tronics to maintain or service the equipment. **THE WARRANTIES AND REMEDIES CONTAINED HEREIN ARE IN LIEU OF AND EXCLUDE ALL OTHER WARRANTIES AND REMEDIES, WHETHER EXPRESS OR IMPLIED BY OPERATION OF LAW OR OTHERWISE, INCLUDING ANY WARRANTIES OF MERCHANTABILITY OR FITNESS FOR A PARTICULAR PURPOSE.**

## Return Policy

---

If the equipment requires service, contact your Regional Service Center for a return authorization number (RA#). Equipment should be shipped prepaid to GAI-Tronics with a return authorization number and a purchase order number. If the equipment is under warranty, repairs or a replacement will be made in accordance with the warranty policy set forth above. Please include a written explanation of all defects to assist our technicians in their troubleshooting efforts.

Call 800-492-1212 (inside the USA) or 610-777-1374 (outside the USA) for help identifying the Regional Service Center closest to you.