



GAI-TRONICS®
A HUBBELL COMPANY

SP2 Weatherproof Class I Div. 2 Handset/Speaker Amplifier Station

TABLE OF CONTENTS

<i>Confidentiality Notice</i>	<i>1</i>
<i>General Information</i>	<i>1</i>
Product Overview	1
Features	2
Options	2
<i>Installation</i>	<i>3</i>
Important Safety Instructions	3
Mounting the Enclosure	4
Cable Entries	4
Opening the Station	5
Field Wiring and Configuration	5
Station Ground.....	5
Termination PCBA	6
Main PCBA.....	10
<i>Settings and Adjustments</i>	<i>12</i>
Opening the Station	12
Main PCBA Configuration	12
Write Protect (EEPROM) Jumper.....	12
WDOG Enable (Watchdog) Jumper	12
Boot Enable Jumper	12
Reset Switch.....	13
Speaker and 600-ohm Audio Output Volume.....	13
Receiver Volume	14
Group and Station Number Selector Switches.....	14
Main PCBA Indicators	14
Power LED.....	14
Heartbeat LED	14
Ethernet Connection LEDs	14
Five Configurable LEDs	15
Attaching the Front Cover	15
<i>Programming</i>	<i>15</i>
<i>Operation</i>	<i>15</i>
Standard Handset Paging	15

Party Line Communication	15
All-Call Button Use	16
Alternate-Page Destination Switch Use	17
Headset Use	17
<i>Maintenance</i>	<i>18</i>
Troubleshooting	18
Service and Spare Parts	19
<i>Specifications</i>	<i>19</i>
<i>Approvals</i>	<i>21</i>



GAI-TRONICS®
A HUBBELL COMPANY

SP2 Weatherproof Class I Div. 2 Handset/Speaker Amplifier Station

Confidentiality Notice

This manual is provided solely as an installation, operation, and maintenance guide and contains sensitive business and technical information that is confidential and proprietary to GAI-Tronics. GAI-Tronics retains all intellectual property and other rights in or to the information contained herein, and such information may only be used in connection with the operation of your GAI-Tronics product or system. This manual may not be disclosed in any form, in whole or in part, directly or indirectly, to any third party.

This product contains copyrighted computer programs stored in semiconductor memory. These programs are copyrighted by GAI-Tronics Corporation and may not be reproduced in any form without express written permission from GAI-Tronics.

General Information

Product Overview

The GAI-Tronics SP2 station is a modular industrial multicast VoIP (Voice over Internet Protocol) communication system. The Weatherproof Class I Div. 2 SP2 configuration is an outdoor, multi-party, handset/speaker amplifier station using ac power with RTU control. They are constructed of engineered plastic with a powder coated aluminum front panel. A number of options are available to add to or modify station capabilities (see the [Features](#) and [Options](#) sections below).

SP2 stations connect to an Ethernet network so the loss of a single station will not adversely affect the system as a whole. The stations require a 100 Mbps link to a switch or router using Category 5 or better cable. To ensure the quality of SP2 audio, it is recommended that SP2 network traffic be isolated from other devices and that network switches and routers be properly configured for IGMP (Internet Group Management Protocol) snooping and multicast filtering. Maximum cable runs between fiber SP2 stations and network switches are limited to 100 meters to comply with Ethernet standards..

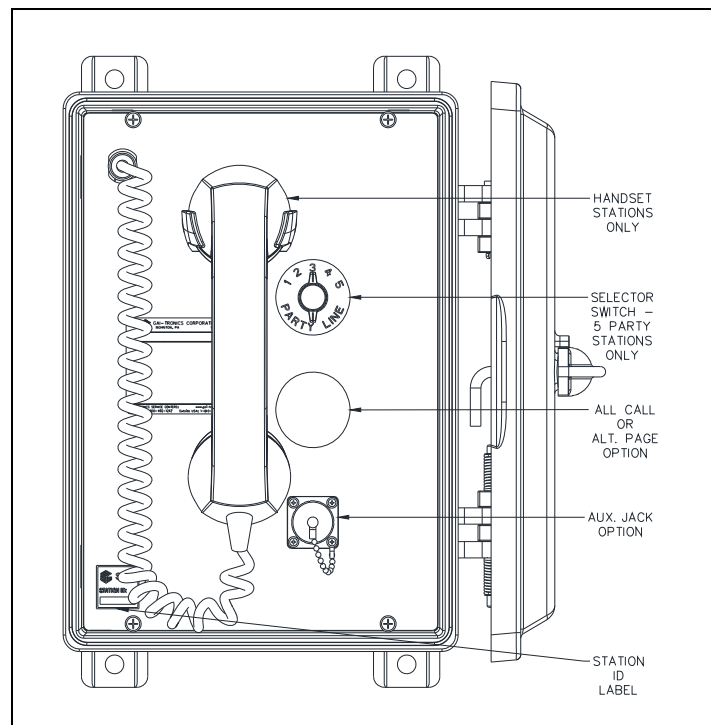

Figure 1. SP2 Station Front Panel

Features

- flexible and highly configurable SMART technology featuring ALS (ambient level sensing), real time self-diagnostics, and available remote monitoring
- real-time operation providing instantaneous page and party line communication
- no SIP server or conference bridge requirement
- one-way live paging and alarm annunciation over system speakers
- distributed amplifier topology—loss of an individual amplifier will not adversely affect the system as a whole
- mutual provisioning mode allows easy system deployment
- high efficiency (>80%) Class D paging amplifier provides up to 30 watts of speaker output at 8 ohms
- five configurable multicast channels for full-duplex conference communication with party line selector switch
- eight configurable multicast channels for receiving page announcements
- one isolated output for beacon activation
- two isolated inputs
- 600-ohm audio I/O with control
- configurable priority scheme allows urgent/emergency pages to override less important pages
- configuration stored in non-volatile memory
- field adjustable volume control for handset earpiece, headset earpiece, and speaker amplifier
- configurable local and nearby speaker mutual muting to prevent acoustic feedback of live pages
- configurable *preannouncement* tone
- off-hook and page switch timeout functionality
- configurable virtual zoning ability
- USB interface for field or bench configuration
- universal ac power supply
- engineered plastic enclosure with powder coated aluminum front panel

Options



All SP2 Station options are factory installed.

- 24 V dc power supply
- speaker amplifier only (no handset)
- headset with page pressbar for loud environments
- five configurable multicast channels for alternate page destinations with page line selector
- All-Call push button for secondary page destination
- PVC or Hytrel[®] handset cords in 6-, 15-, or 25-foot lengths
- conformal coating for PCBA



Installation



Important Safety Instructions



- Read, follow, and retain instructions—All safety and operating instructions should be read and followed before operating the unit. Retain instructions for future reference.
- Heed warnings—Adhere to all warnings on the unit and in the operating instructions.
- Attachments—Attachments not recommended by the product manufacturer should not be used, as they may cause hazards.
- Servicing—Do not attempt to service this unit by yourself. Opening or removing covers may expose you to dangerous voltage or other hazards. Refer all servicing to qualified service personnel.

 **ATTENTION**  —Install equipment without modification and according to all applicable local, national and international electrical codes. North America—Consult the National Electrical Code (NFPA 70), Canadian Standards Association (CSA 22.1), and local codes for specific requirements regarding your installation. Class 2 circuit wiring must be performed in accordance with NEC 725.55.

This equipment is suitable for use in Class I Division 2 Groups A, B, C and D, Class II Division 2 Groups F and G, Class III, OR non-hazardous locations only. Combinations of equipment in your system are subject to investigation by the local authority having jurisdiction at the time of installation.

 **WARNING**  —**EXPLOSION HAZARD**—Do not disconnect equipment unless power has been removed or the area is known to be non-hazardous. Avertissement—Risque d'explosion—avant de déconnecter l'équipement, couper le courant ou s'assurer que l'emplacement est désigné non dangereux.

 **WARNING**  —Do not install this equipment in hazardous areas other than those indicated on the approval listing in the “Specifications” section of this manual. Such installation may cause a safety hazard and consequent injury or property damage.

 **WARNING**  —In 24 V dc systems: Under NO condition should this equipment be operated from a battery charger without the batteries connected.

In 24 V dc systems, most chargers have an unloaded output of 35 to 45 volts that can quickly damage the equipment designed for nominal 24 volts. The maximum battery voltage should never exceed the maximum specified input voltage.

 **WARNING**  —**Do not disconnect equipment while energized.**
Ensure proper grounding to protective earthing.

These enclosures must be installed by trained, qualified and competent personnel. Installation must comply with state and national regulations, as well as safety practices for this type of equipment. The mounting location must be flat and provide proper clearance, rigidity, and strength to support the enclosure and all contained devices.

Mounting the Enclosure

Mount the enclosure using the four 0.437-inch (11 mm) diameter holes located on the mounting flanges with 3/8-inch (M8) hardware. The suggested mounting height for all station enclosures is 48 inches (1219 mm) to the center of the bottom mounting holes of the enclosure. The Standard Weatherproof Class I Div. 2 station is not supplied with conduit or cable openings.

Cable Entries

Remove the front panel and drill or punch entry openings in the rear section of the enclosure (See [Figure 2](#)). The station is suitable for side or bottom entry; however, bottom entry is recommended to ensure moisture intrusion does not take place. There must be a minimum of 1/2 inch (13 mm) of material between entry holes.

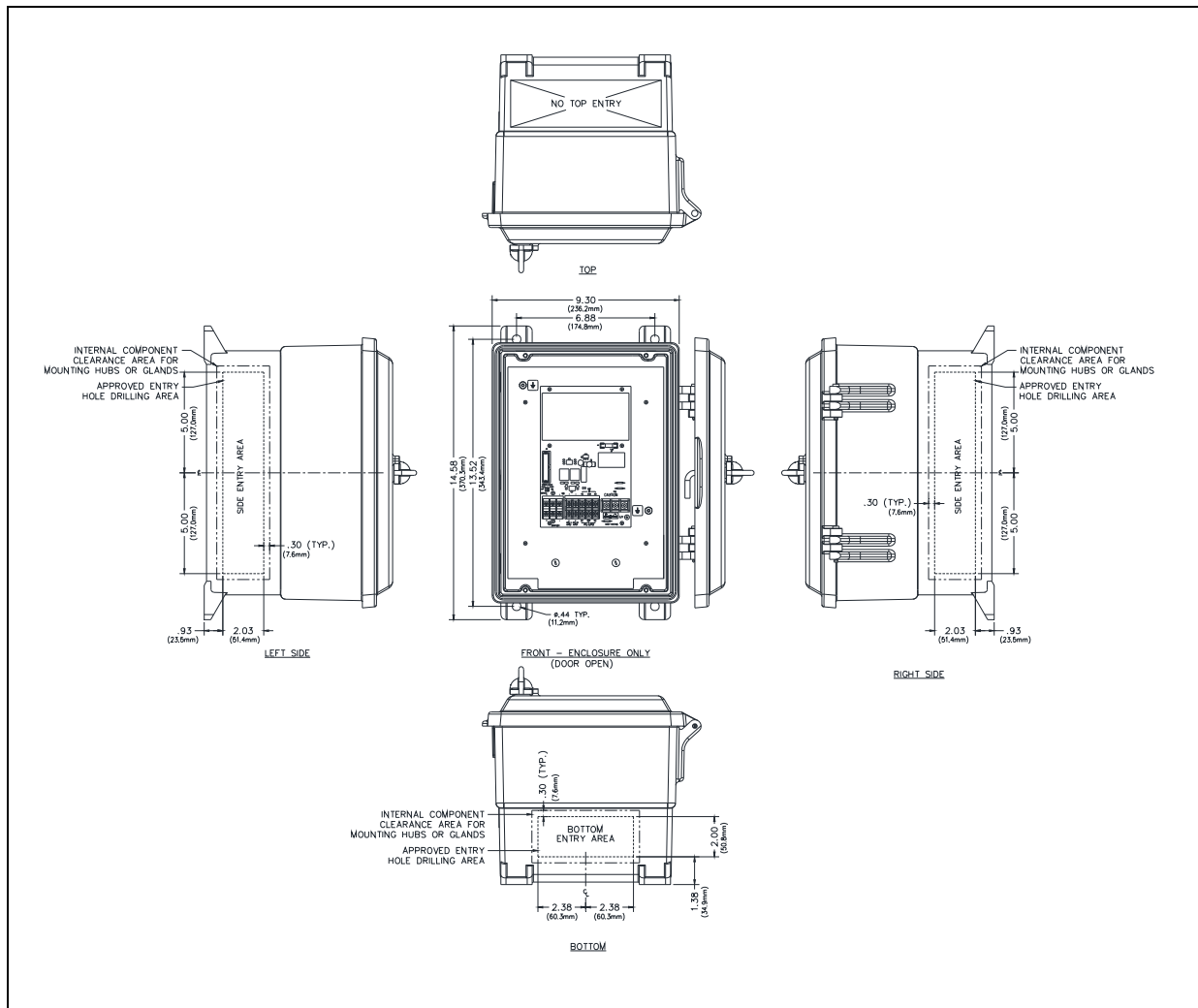

Figure 2. Suggested Wire Entry Locations

Opening the Station

Complete the following steps to open the station:

1. Remove the four screws from the front panel and turn it to the left so that the interior surface faces you.
2. Keep the wiring and ribbon cables connected.

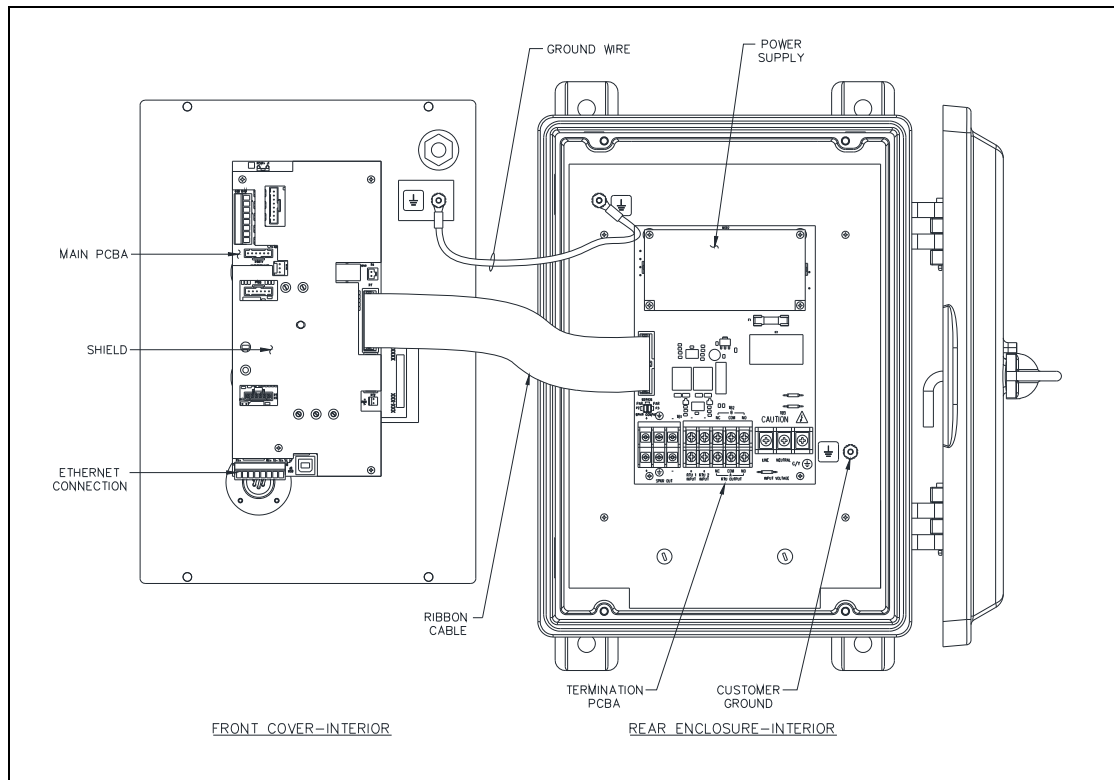

Figure 3. SP2 Weatherproof Class I Div. 2—Interior View

Field Wiring and Configuration

The Weatherproof Class I Div. 2 SP2 Station provides terminal blocks on the Termination PCBA located in the rear of the enclosure for field wiring the power, speaker, and RTU connections. The Main PCBA, mounted to the back of the front panel, provides pluggable terminal blocks for the Ethernet and 600-ohm audio connections.

NOTE: Consult the National Electrical Code (NFPA 70), Canadian Standards Association (CSA 22.1), and local codes for the specific requirements regarding your installation. Install all equipment without modification and according to the local and national codes. Class 2 circuit wiring must be performed in accordance with NEC 725.55.

NOTE: Shielded Ethernet cable or metallic conduit is required for installation.

Station Ground

The station enclosure must be connected to earth ground.

1. Install a #6 ring lug on the ground conductor.
2. Secure it to the ground terminal located in the lower right corner at the back of the rear enclosure (see [Figure 3](#)).

Termination PCBA

Install all connections as indicated in the following sections:

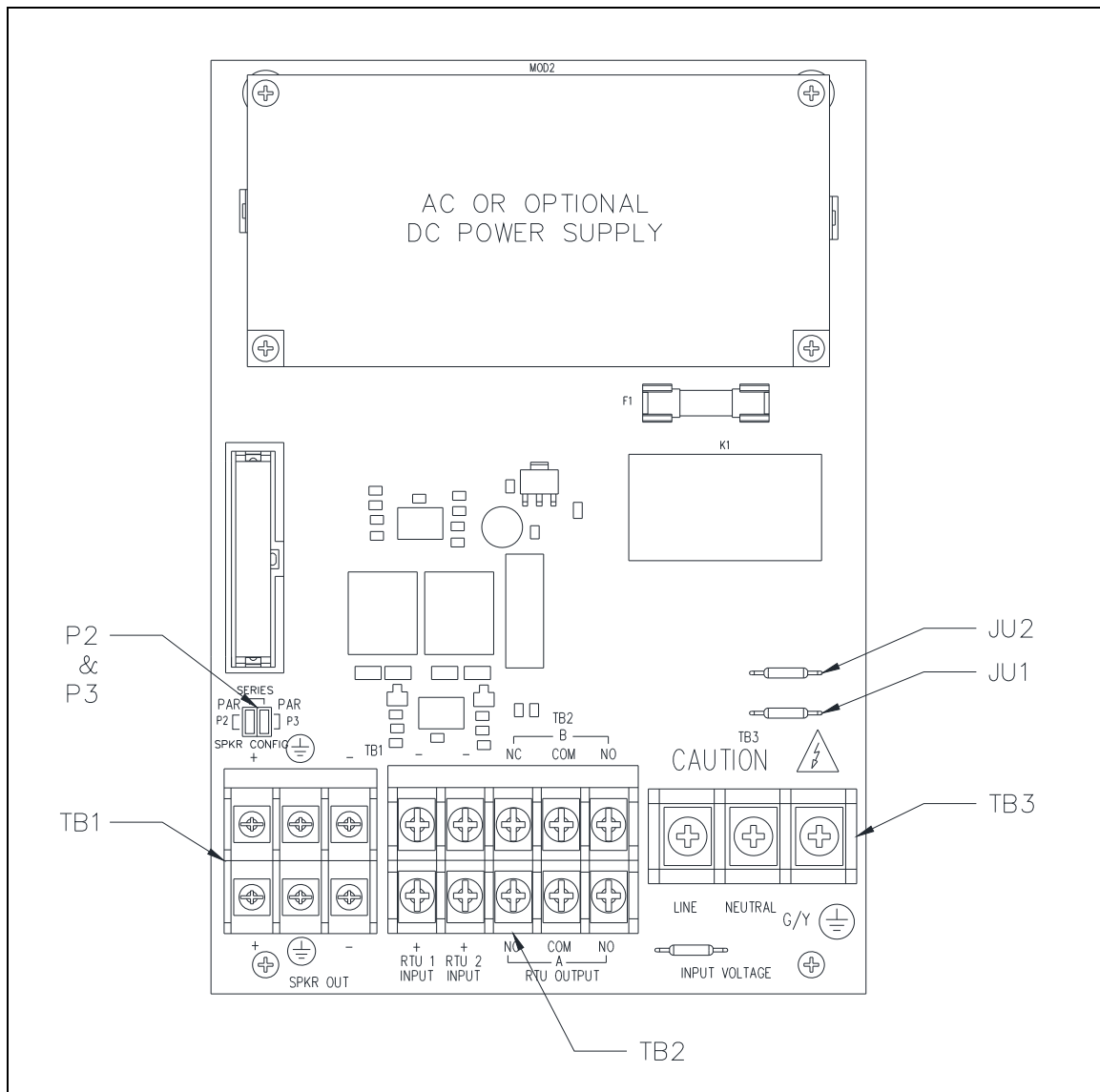

Figure 4. SP2 Standard Termination PCBA
(Optional 70V/100V Termination PCBA Similar)

Direct Speaker Connection and Jumper Settings

Terminal block TB1 provides termination for the station's 8 or 16-ohm remote speaker(s).

1. Pull the speaker cable(s) into the enclosure.
2. Connect spade lugs to the wires.
3. Install the speaker wires to terminal block TB1 in accordance with the table below.
4. Torque the terminal block screws to 8–10 in·lb (0.90–1.13 N·m).
5. Configure the speaker jumpers; P2 and P3, for the appropriate impedance for use with 8-ohm or 16-ohm speakers (see Figure 4 and Figure 5).

A redundant set of terminals is provided for a second speaker branch that can be connected in series or parallel with the primary speaker.

Table 1. Direct Speaker Connections—TB1

Pin	Label	Description
TB1-1	+	Parallel/SPEAKER A Series—Output
TB1-2	⊥	Earth Reference
TB1-3	-	Parallel/SPEAKER A Series—Output
TB1-4	+	Parallel/SPEAKER B Series—Output
TB1-5	⊥	Earth Reference
TB1-6	-	Parallel/SPEAKER B Series—Output

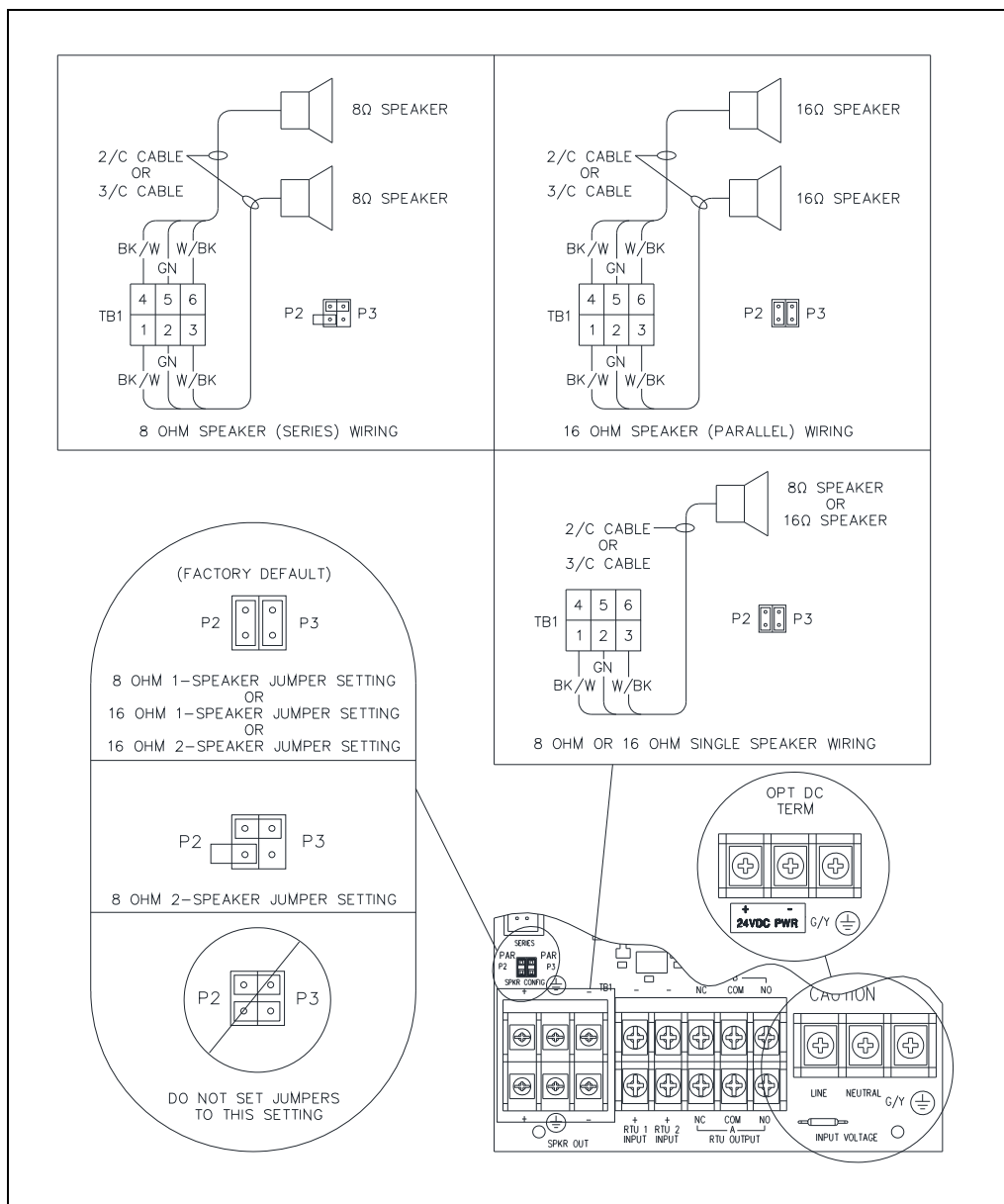

Figure 5. 8/16-ohm Speaker Impedance Configuration and AC/DC Termination at TB3

RTU Inputs

The standard Termination PCBA contains two auxiliary RTU inputs. These inputs are terminated at terminal block TB2 (see [Figure 5](#)).

1. Pull the RTU Input cable(s) into the enclosure.
2. Connect spade lugs to the wires.
3. Install the RTU Input wires to terminal block TB2 (see [Table 2](#)).
4. Torque the terminal block screws to 8–10 in·lb (0.90–1.13 N·m).
5. Install end-of-line resistors as shown to enable RTU input-cable monitoring (see [Figure 6](#)).

Table 2. Standard Termination Board
RTU Input Termination—TB2

Pin	Label	Function
TB2-1	+ RTU 1 INPUT	RTU Input 1 +
TB2-2	-	RTU Input 1 -
TB2-3	+ RTU 2 INPUT	RTU Input 2 +
TB2-4	-	RTU Input 2 -

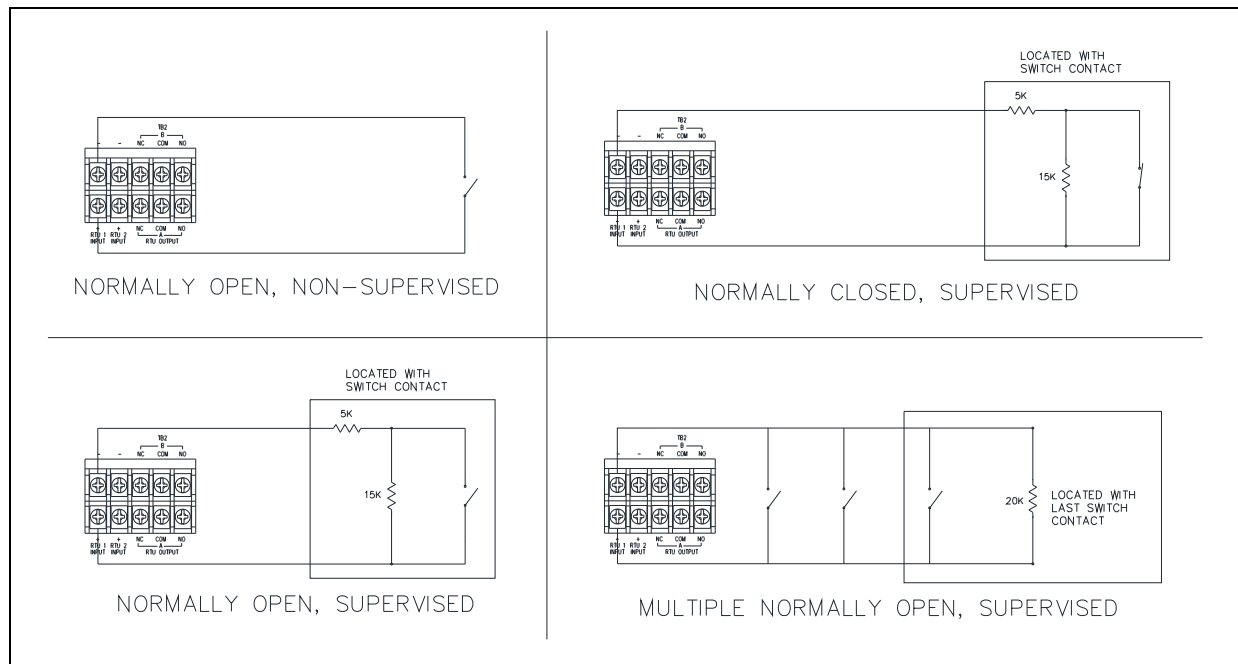

Figure 6. RTU Input Wiring Configurations for Cable Monitoring

RTU Output

Two Form “C” contacts are provided to power a beacon (see [Figure 7](#)). These outputs can be reconfigured for dry contact use by removing jumpers JU1 and JU2. Termination for these outputs is provided at terminal block TB2 on the Termination PCBA (see [Figure 5](#)).

⚠ WARNING ⚠ —Line voltage is present at the NO contact until JU1 and JU2 are removed.

1. Pull the RTU Output cable into the enclosure.
2. Connect spade lugs to the wires.
3. Install the RTU Output wires to terminal block TB2 (see [Table 3](#)).
4. Torque the terminal block screws to 8–10 in·lb (0.90–1.13 N·m).

For beacon cable monitoring:

5. Install a 20-kilohm 10-watt resistor across the terminals of the beacon cable (see [Figure 7](#)).
6. Install jumpers at TB2 as shown below to enable cable monitoring.

NOTE: If an RTU Input is used to monitor beacon wiring then it is not available for other functions.

Table 3. RTU Output Contacts—TB2

Pin	Label	Description
TB2-5	NC A	Normally Closed Output A
TB2-6	NC B	Normally Closed Output B
TB2-7	COM A	Common Output A
TB2-8	COM B	Common Output B
TB2-9	NO A	Normally Open Output A
TB2-10	NO B	Normally Open Output B

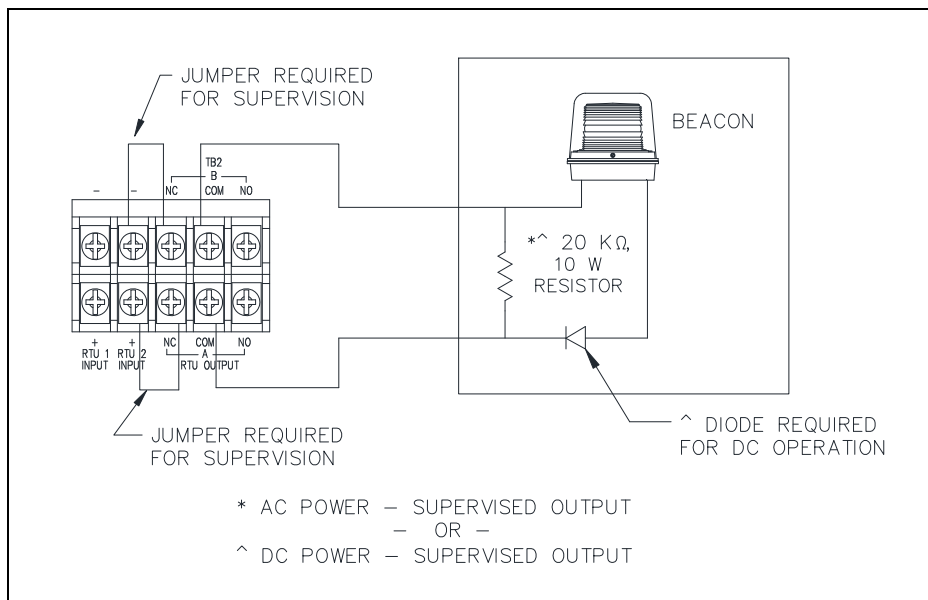

Figure 7. Supervised Output Wiring—TB2

Power

The ac or optional dc power supply is mounted on the Termination PCBA. The termination PCBA includes terminal block TB3 for connecting the local power source to the station (see [Figure 5](#)):

1. Pull the cable from the power source into the enclosure.
2. Connect spade lugs to the wires.
3. Connect the conductors from the ac or dc power source to the appropriate terminals at terminal block TB3:

Table 4. AC Power—TB3

Pin	Label	Description
TB3-1	LINE	Positive
TB3-2	NEUTRAL	Negative
TB3-3	⏏	Earth ground

Table 5. DC Power—TB3

Pin	Label	Description
TB3-1	+	Positive
TB3-2	-	Negative
TB3-3		No Connection

Main PCBA

600-Ohm Audio I/O with Control

SP2 stations provide a 600-ohm audio input to facilitate broadcasting line level audio over the page line. A control input exists that requires a normally open dry contact closure to enable the station to broadcast the 600-ohm input audio. SP2 stations also provide a 600-ohm audio output for sending page line audio to a remote audio amplifier. A solid state dry contact relay is provided that can be used to control when the remote audio amplifier plays the audio.

1. Pull the cable for the 600-ohm audio I/O into the enclosure.
2. Install ferrules onto the wire ends.
3. Connect the 600-ohm audio wires to the pluggable terminal block for the 600-ohm audio I/O connection (see [Table 6](#) and [Figure 8](#)).
4. Connect the pluggable terminal block to terminal block receptacle TB1.

Table 6. 600-Ohm Audio I/O Interface Connections—TB1

Pin	Label	Description
TB1-1	IN CT1+	Input Control Positive
TB1-2	IN CT1-	Input Control Negative
TB1-3	IN AUD+	Input Audio Positive
TB1-4	IN AUD-	Input Audio Negative
TB1-5	OUT AUD+	Output Audio Positive
TB1-6	OUT AUD-	Output Audio Negative
TB1-7	OUT CT1+	Output Control Positive
TB1-8	OUT CT1-	Output Control Negative

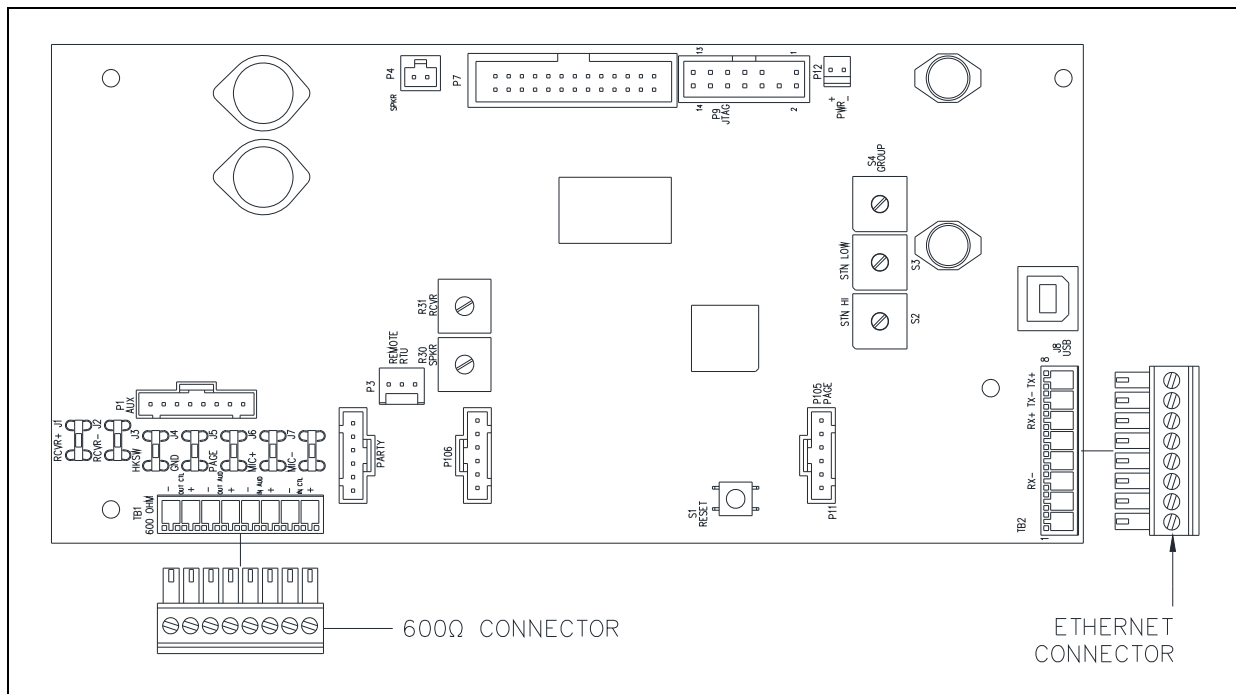

Figure 8. SP2 Main PCBA (Ethernet)

Ethernet Termination

1. Pull a dedicated category-5 or better Ethernet cable into the rear enclosure.
2. Install ferrules onto the wire ends.
3. Connect the Ethernet cable to the 8-position pluggable terminal block (see [Figure 8](#))
4. Connect the pluggable terminal block to the Main PCBA terminal block TB2 (see [Figure 8](#)).

NOTE: Shielded Ethernet cable or metallic conduit is required for installation.

Table 7. Ethernet Connection—TB2

Pin	Label	Description
TB2-1		Unused
TB2-2		Unused
TB2-3	RX-	Data Receive -
TB2-4		Unused
TB2-5		Unused
TB2-6	Rx+	Data Receive +
TB2-7	TX-	Data Transmit -
TB2-8	TX+	Data Transmit +

Settings and Adjustments

Opening the Station

Complete the following steps to open the station:

1. Remove the four screws from the front panel and turn it to the left so that the interior surface faces you.
2. Keep the wiring and ribbon cables connected.

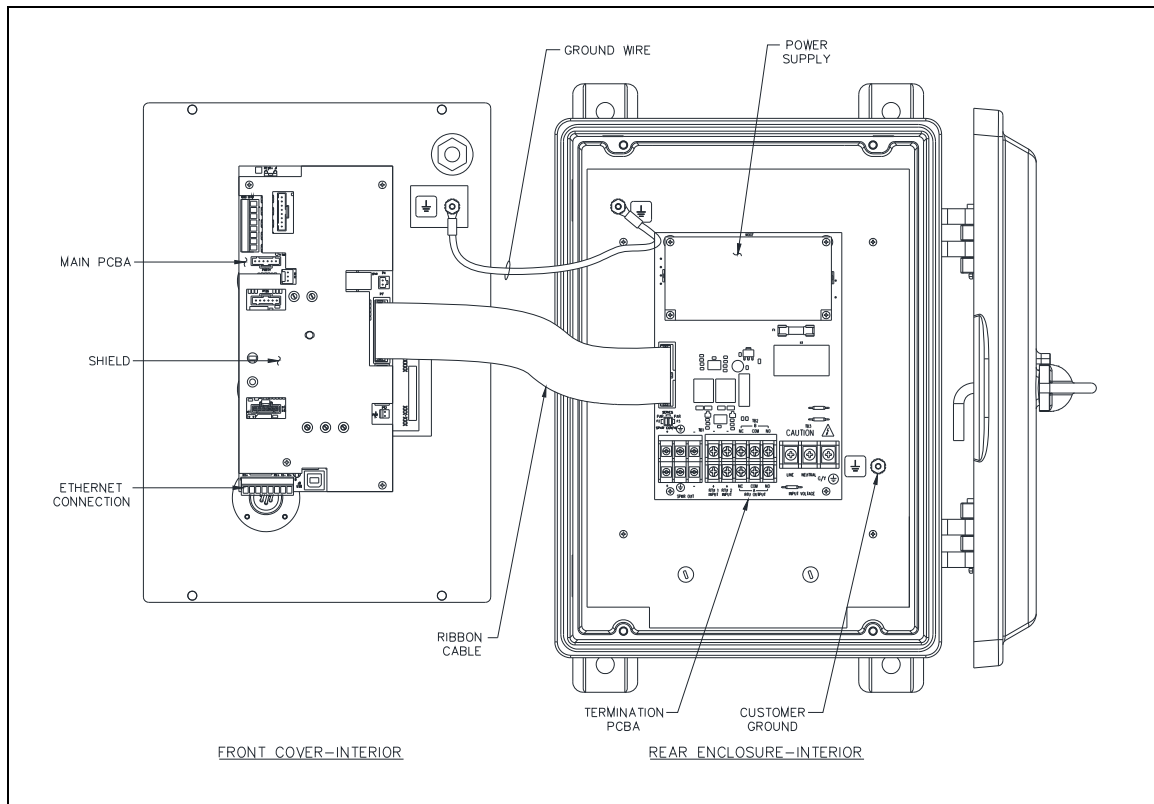

Figure 9. SP2 Weatherproof Class I Div. 2—Interior View

Main PCBA Configuration

Refer to [Figure 10](#) for switch, jumper, and LED locations on the Main PCBA.

Write Protect (EEPROM) Jumper

NOTE: This jumper should not be changed in the field.

WDOG Enable (Watchdog) Jumper

Watchdog jumper, P11, enables a watchdog feature for software purposes and should not be adjusted in the field. The default setting is installed.

Boot Enable Jumper

Jumper P8—BOOT, is required for development purposes and should not be adjusted in the field. The default setting for this jumper is open.

Reset Switch

Reset switch, S1 reboots the station to its initial state. All configuration settings remain programmed.

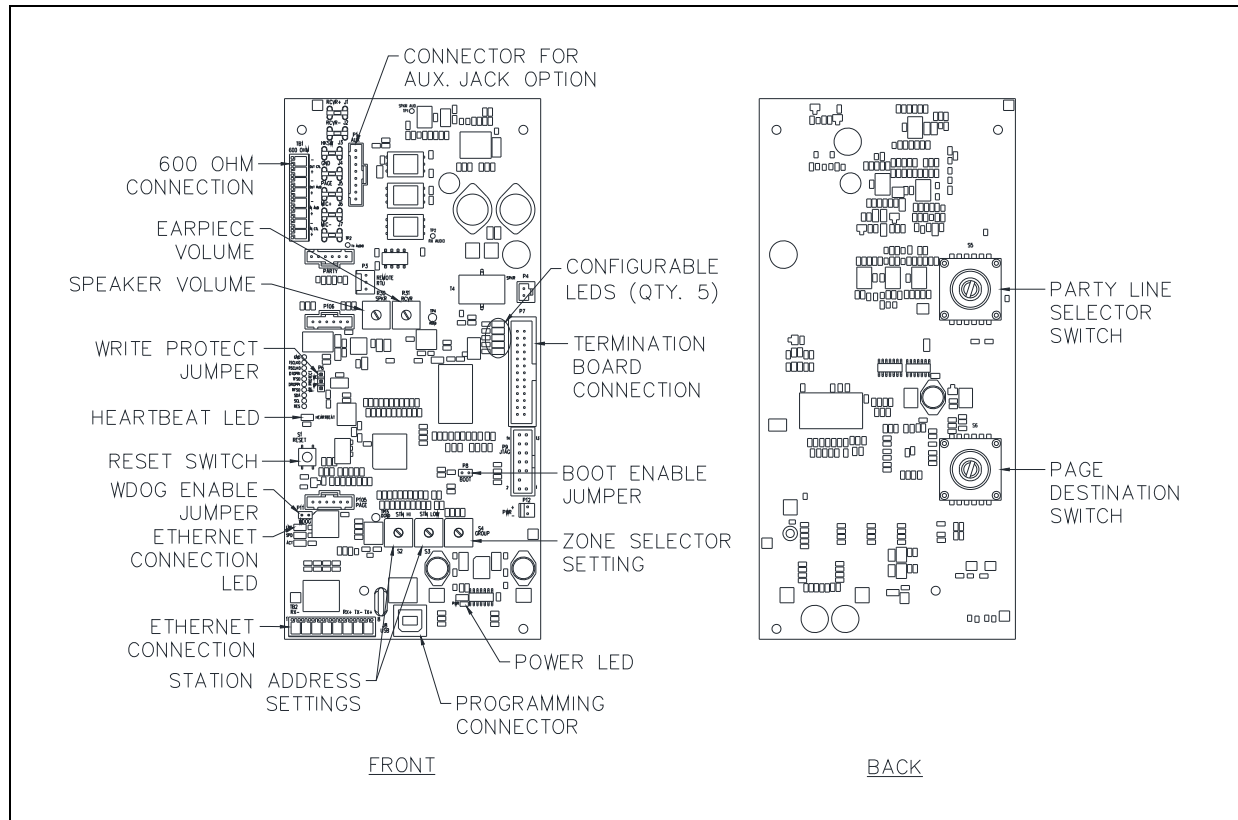

Figure 10. Main PCBA (Front and Rear Views)

Speaker and 600-ohm Audio Output Volume

The speaker volume potentiometer, R36, adjusts the signal level to the speaker from the page line. When 600-ohm audio is also connected, R36 will adjust the volume for both. If only 600-ohm audio is utilized then the volume for the 600-ohm audio must be configured via the CLI (Command Line Interface). The default setting is 4 watts from an 8-ohm speaker and 2 watts from a 16-ohm speaker.

⚠ WARNING ⚠ —Maximum output power may exceed rated speaker wattage resulting in speaker damage.

To adjust the speaker or speaker and 600-ohm output volume:

1. Turn the SPKR speaker volume potentiometer R36 fully counter-clockwise. An audible test-tone will be heard from the speaker.
2. Slowly turn R36 clockwise until the desired output volume is reached. The test-tone ceases three seconds after no adjustment has been made.

This setting can also be configured via USB or Ethernet connection using the CLI.

NOTE: This setting is overridden if it is configured for the station using the SP2 Console in a mutually provisioned system. See the SP2 Configuration Guide, Pub. 42004-784.

Receiver Volume

The Receiver Volume is adjusted using the RCVR potentiometer R37. To adjust the volume for the handset:

1. Remove the handset from the cradle.
2. Turn the RCVR potentiometer R37 fully counter clockwise. An audible test-tone will be heard in the handset.
3. Slowly turn R36 clockwise until the desired output volume is reached. The test-tone ceases three seconds after no adjustment has been made.

This setting can also be configured via USB or Ethernet connection using the CLI.

NOTE: This setting will be overridden if it is configured for the station using the SP2 Console in a mutually provisioned system. See the SP2 Configuration Guide, Pub. 42004-784.

Group and Station Number Selector Switches

One Group-Number and two Station-Number hex-selector switches are used to configure SP2 stations for Mutual Provisioning (see [Figure 10](#)). Each hex switch has a small arrow to indicate the current setting.

1. Adjust the position of the Group-Number selector switch to the desired group [0-F].
2. Adjust the two Station-Number switches to assign the station number [00–FF]. No two stations can be assigned the same address.

At least one SP2 station must be configured as a Master Station to utilize Mutual Provisioning in an SP2 system. Master stations must be assigned addresses [0.01], [0.02], or [0.03] using the selector switches. Master station(s) store the configuration of all SP2 stations on the network. As SP2 stations are powered on, they retrieve the mutual provisioning configuration from the master station. See Pub. 42004-784, SP2 Configuration Guide, for detailed information on configuring SP2 stations and SP2 system mutual provisioning. GAI-Tronics' product documentation is located on the GAI-Tronics website at <https://www.gai-tronics.com>.

Main PCBA Indicators

Power LED

The Power LED located on the Main PCBA illuminates when power is applied to the station indicating the main board power supply is operational (see [Figure 10](#)).

Heartbeat LED

The Heartbeat LED located on the Main PCBA will flash once communication over the LAN is established to indicate the microprocessor is operational (see [Figure 10](#)).

Ethernet Connection LEDs

Three Ethernet connection LEDs are located on the Main PCBA; Link (LNK), Link Speed (SPD), and Activity (ACT). The LNK LED is blue, the SPD LED is green, and the ACT LED is yellow. The LNK and SPD LEDs must be off to indicate that a 100 Mbps Ethernet link is active. The activity LED; ACT, will blink yellow to indicate Ethernet data activity (see [Figure 10](#)).

Five Configurable LEDs

Five LEDs are located on the Main PCBA (see [Figure 10](#)). These LEDs are configured through firmware. Information for configuring these LED indicators is provided in the SP2 Configuration Guide, Pub. 42004-784. GAI-Tronics' product documentation is located on the GAI-Tronics website at <https://www.gai-tronics.com>.

Attaching the Front Cover

After all adjustments have been completed, place the front cover onto the rear enclosure, being careful not to pinch any cables. Secure the front cover using the four screws and washers provided. Torque the screws to 50 in·lb (5.65 N·m).

Programming

SP2 stations are factory configured to provide basic Page/Party[®] functions upon power-up. For custom configurations and larger system designs the stations may need to be reconfigured. Refer to Publication 42004-784, SP2 Configuration Guide, located on the GAI-Tronics website at <https://www.gai-tronics.com>.

Operation

Standard Handset Paging

Complete the following steps to make a page announcement from an SP2 handset station:

1. Lift the handset from the cradle.
2. If party line conversation is desired, rotate the selector switch to an unoccupied party line.
3. Press and hold the handset pressbar (not necessary when using the optional ALL-CALL button).
4. After a short *preannouncement* tone is heard (if configured), speak directly into the microphone to broadcast your page announcement.

NOTE: SP2 stations incorporate a noise-canceling microphone to reduce transmitted ambient noise. This requires the user to place the microphone as close as possible to their mouth.

5. Release the handset pressbar and wait for a response on the party line (if requested) or replace the handset in the cradle.

Party Line Communication

To respond to a page:

1. Turn the selector switch on any SP2 station in the system to the requested party line.
2. Pick up the station handset and party line communication can occur.

NOTE: SP2 stations incorporate a noise-canceling microphone to reduce transmitted ambient noise. This requires the user to place the microphone as close as possible to their mouth.

3. Return the handset to the cradle following the party line conversation.

Party line conversations are not broadcast over the system speakers. Other individuals can join the conversation at any time by picking up a handset rotating the selector switch to the party line in use.

All-Call Button Use

Use the ALL-CALL option button to page an alternate destination that has been programmed for the station (see [Figure 11](#)). The All-Call option must be software configured for the SP2 station. To initiate a page using the ALL-CALL feature:

1. Lift the handset from the cradle.
2. If party line conversation is desired, rotate the selector switch to an unoccupied party line.
3. Press and hold the ALL-CALL button.

The ALL-CALL button eliminates the need to press the handset or headset pressbar when paging.

4. After a short *preannouncement* tone is heard (if configured), speak directly into the microphone to broadcast your page announcement.

NOTE: SP2 stations incorporate a noise-canceling microphone to reduce transmitted ambient noise. This requires the user to place the microphone as close as possible to their mouth.

5. Release the ALL-CALL button and wait for a response on the party line (if requested).
6. Return the handset to the cradle when finished.

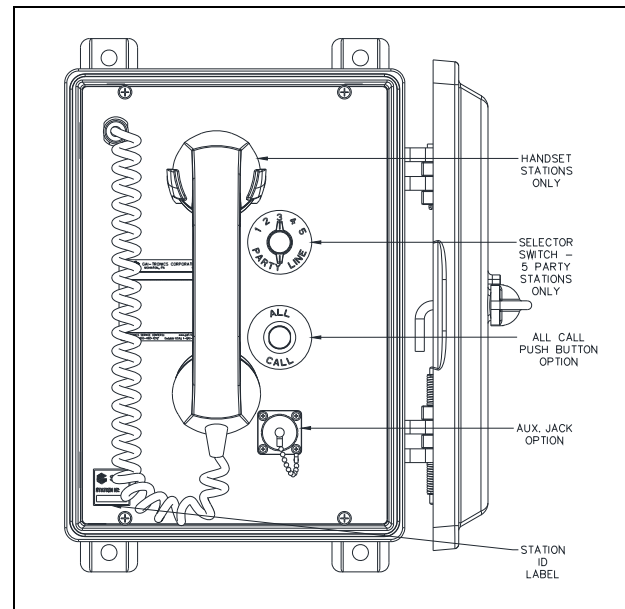

Figure 11. All-Call Button Option

Alternate-Page Destination Switch Use

Use the ALT-PAGE option selector switch to page one of five alternate destinations that have been programmed for the station (see [Figure 12](#)).

Alternate page destinations must be software configured for the SP2 station. To initiate a page using the ALL-CALL feature:

1. Lift the handset from the cradle.
2. If party line conversation is desired, rotate the selector switch to an unoccupied party line.
3. Select the desired page destination using the ALT-PAGE selector switch.
4. Press and hold the handset pressbar.
5. After a short *preannouncement* tone is heard (if configured), speak directly into the microphone to broadcast your page announcement.

NOTE: SP2 stations incorporate a noise-canceling microphone to reduce transmitted ambient noise. This requires the user to place the microphone as close as possible to their mouth.

6. Release the handset pressbar.
7. Return the handset to the cradle or wait for a response on the party line (if requested).

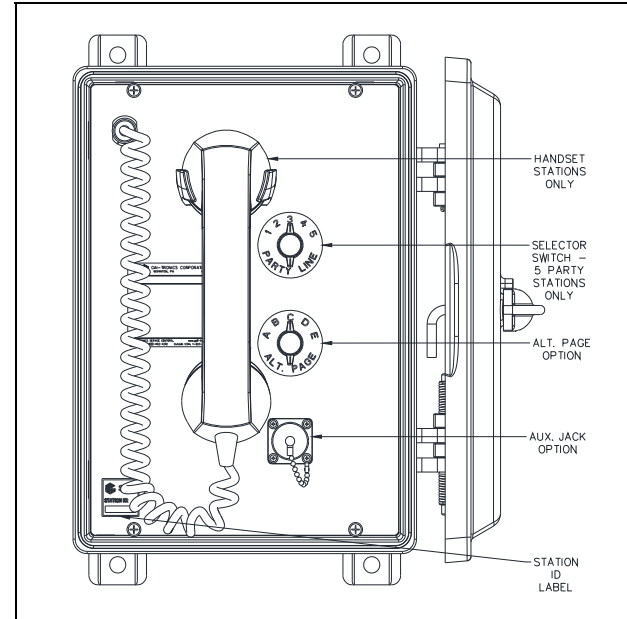

Figure 12. Alternate-Page Switch Option

Headset Use

Initiate a call with the optional headset feature as follows:

1. Attach the headset assembly to the auxiliary jack on the station (see [Figure 11](#) or [Figure 12](#)).
2. If party line conversation is desired, rotate the selector switch to an unoccupied party line.
3. Rotate the ALT-PAGE selector switch (if available), or press the ALL-CALL button (if available) to select the desired optional destination for the page announcement.
4. Press and hold the headset pressbar (not necessary when using the optional ALL-CALL button).
5. After a short *preannouncement* tone is heard (if configured), speak directly into the microphone to broadcast your page announcement.
6. Release the headset pressbar.
7. Wait for a response on the party line (if requested).

NOTE: For stations with an auxiliary jack, the Model 10401-201 Headset and 10416-103 Extension Cord allow the user to be hands-free and mobile while maintaining communication. When connected, the handset microphone is disabled.

Maintenance

Troubleshooting

The following table is provided to aid qualified service personnel in troubleshooting problems with the SP2 Station.

Problem	Solution
station not functional	<ul style="list-style-type: none"> • check wiring and cable terminations • check power supply voltage at TB3 on Termination PCBA • Power LED on Main PCBA illuminated • Heartbeat LED blinking once per second for normal operation
network communication not functional	<ul style="list-style-type: none"> • verify LNK LED on main PCBA is off • verify SPD LED on main PCBA is off • verify IP connection settings using telnet • ping station IP address from an admin PC • verify network switch settings for Internet Group Management Protocol (IGMP) snooping and multicast filtering
Handset receiver audio is too high/low	<ul style="list-style-type: none"> • adjust the <u>Receiver Volume</u> • check potentiometer R37 setting • check handset connections • check cable terminations between the Termination and Main PCBAs • check hookswitch operation • replace handset
speaker volume is too high/low	<ul style="list-style-type: none"> • adjust the <u>Speaker and 600-ohm Audio Output Volume</u> • check potentiometer R36 setting • P2 and P3 Termination PCBA jumper positions incorrect (see <u>Figure 5</u>) • check speaker wiring configuration on TB1 • replace the speaker or driver
RTU output is not functional	<ul style="list-style-type: none"> • verify no monitored output faults exist • check fuse F1 on the Termination PCBA • check connected device operation
RTU input does not function	<ul style="list-style-type: none"> • verify no monitored input faults exist • check <u>RTU Inputs</u> on TB2 • Check operation of connected device.

Service and Spare Parts

If the equipment requires service or spare parts, contact your Regional Service Center for assistance. If service is required, a return authorization number (RA#) will be issued. Equipment should be shipped prepaid to GAI-Tronics with a return authorization number and a purchase order number. If the equipment is under warranty, repairs or a replacement will be made in accordance with GAI-Tronics' warranty policy. Please include a written explanation of all defects to assist our technicians in their troubleshooting efforts. Call 800-492-1212 inside the USA or 610-777-1374 outside the USA for help with identifying the Regional Service Center closest to you.

Specifications

Power

AC Input

Input voltage 120/230 V ac (nominal), 50/60 Hz

Power factor @ nominal 120 V ac 0.5

DC Input

Input voltage 24 V dc +/-20%

Power Consumed (8-ohm load)	120 V AC	230 V AC	24 V DC
Idle	80 mA/6.6 VA	50 mA/12 VA	165 mA/4.0 W
4-watt output (default setting)	150 mA/18 VA	110 mA/25 VA	460 mA/11.0 W
30-watt output	550 mA/65 VA	350 mA/80 VA	1.95 A/46.8 W
Maximum Current Consumed (8-ohm load)	108 V AC	253 V AC	19.2 V DC
30-watt output	600 mA/65 VA	370 mA/77 VA	2.44 A/46.8 W

Current/Power requirements (+/-10%)

Ethernet

Cable Category 5 or better

Speed 100 Mbps

Maximum Stations 4096

RTU

Input Control

Switch type NO or NC dry contacts

End-of-line termination 20 kΩ, or 15 kΩ + 5.1 kΩ

Cable resistance 100 Ω maximum loop resistance

Contact closure resistance 1 kΩ maximum

Open fault detection >65 kΩ

Short fault detection <200 Ω

Output Control

Maximum load current..... 8 A OUTPUT 1A (unfused)
1.6 A OUTPUT 1B (fused)
Maximum in-rush current 15 A
Maximum voltage250 V ac

Audio

Handset

Microphone..... dynamic, noise-canceling
Receiver dynamic, hearing aid compatible
Cord retractile, 6-foot extended, PVC
Material ABS

Handset Amplifier

Frequency response..... 250–3,000 Hz, +0/–3 dB ref. to 1 kHz
Distortion <1.5% THD @ 1 kHz
Receiver level..... 200 mV nominal, adjustable 100–350 mV

Headset Earpiece

Level 100 mV nominal, adjustable 50–200 mV

Speaker Amplifier

Maximum output:
8-ohm speaker* 30 W into 8-Ω load with –6 dBfs data signal
adjustable to 30 W; default: 4 W @ 8 Ω
16-ohm speaker 15 W into 16-Ω load with –6 dBfs data signal
adjustable to 15 W; default: 2 W @ 16 Ω
Frequency response..... 250–3,000 Hz, +0/–3 dB ref. to 1 kHz
Distortion <1% THD @ 1 kHz to 24 W
<3% THD @ 1 kHz to 30 W

600-ohm Audio Input

Audio Level 1 V_(RMS) maximum
Control typeNO dry contact
Control cable resistance 1 kΩ maximum loop resistance

600-ohm Audio Output

Frequency response.....250–3,000 Hz, +0/–3 dB reference to 1 kHz
Distortion <1% THD @ 1 kHz to 1 V_(RMS) into 600 Ω
Audio level..... adjustable 100 mV_(RMS) to 1 V_(RMS) into 600 Ω
Control type NO solid state relay, maximum on resistance; 35 Ω
Control maximum load current 100 mA
Control maximum load voltage..... 24 V ac/dc

Mechanical

Construction/finish.....	engineered glass-reinforced plastic
Mounting.....	wall or column, four 0.44-inch (11 mm) mounting holes
Termination connections.....	screw-type barrier terminal blocks for power, speaker, and RTU
.....	Phoenix connector pluggable terminal for Ethernet
Dimensions	
Enclosure	14.2 H × 10.9 W × 10.5 D in (371 × 276 × 267 mm)
External controls	
Multi-party stations.....	handset hookswitch and party line selector switch
Multi-page stations	page line selector switch
Net weight.....	standard amplifier: 11.0 lb
	multi-party and options stations: 12.0 lb
Shipping weight	standard amplifier: 12.0 lb
	multi-party and options stations: 13.0 lb

Environmental

Temperature range (operation and storage)	-22 °F to 140 °F (-30 °C to 60 °C)
Humidity	95% non-condensing
Outdoor environmental rating	Type 3R, Type 4X with door closed

Approvals

NRTL Listed for USA and Canada.....	Class 1, Groups A, B, C, and D, Division 2
	Class II, Groups F and G, Division 2
	Class III, Division 2 Hazardous Locations
	Temperature Code T4

Warranty

Equipment. GAI-Tronics warrants for a period of one (1) year from the date of shipment, that any GAI-Tronics equipment supplied hereunder shall be free of defects in material and workmanship, shall comply with the then-current product specifications and product literature, and if applicable, shall be fit for the purpose specified in the agreed-upon quotation or proposal document. If (a) Seller's goods prove to be defective in workmanship and/or material under normal and proper usage, or unfit for the purpose specified and agreed upon, and (b) Buyer's claim is made within the warranty period set forth above, Buyer may return such goods to GAI-Tronics' nearest depot repair facility, freight prepaid, at which time they will be repaired or replaced, at Seller's option, without charge to Buyer. Repair or replacement shall be Buyer's sole and exclusive remedy. The warranty period on any repaired or replacement equipment shall be the greater of the ninety (90) day repair warranty or one (1) year from the date the original equipment was shipped. In no event shall GAI-Tronics warranty obligations with respect to equipment exceed 100% of the total cost of the equipment supplied hereunder. Buyer may also be entitled to the manufacturer's warranty on any third-party goods supplied by GAI-Tronics hereunder. The applicability of any such third-party warranty will be determined by GAI-Tronics.

Services. Any services GAI-Tronics provides hereunder, whether directly or through subcontractors, shall be performed in accordance with the standard of care with which such services are normally provided in the industry. If the services fail to meet the applicable industry standard, GAI-Tronics will re-perform such services at no cost to buyer to correct said deficiency to Company's satisfaction provided any and all issues are identified prior to the demobilization of the Contractor's personnel from the work site. Re-performance of services shall be Buyer's sole and exclusive remedy, and in no event shall GAI-Tronics warranty obligations with respect to services exceed 100% of the total cost of the services provided hereunder.

Warranty Periods. Every claim by Buyer alleging a defect in the goods and/or services provided hereunder shall be deemed waived unless such claim is made in writing within the applicable warranty periods as set forth above. Provided, however, that if the defect complained of is latent and not discoverable within the above warranty periods, every claim arising on account of such latent defect shall be deemed waived unless it is made in writing within a reasonable time after such latent defect is or should have been discovered by Buyer.

Limitations / Exclusions. The warranties herein shall not apply to, and GAI-Tronics shall not be responsible for, any damage to the goods or failure of the services supplied hereunder, to the extent caused by Buyer's neglect, failure to follow operational and maintenance procedures provided with the equipment, or the use of technicians not specifically authorized by GAI-Tronics to maintain or service the equipment. **THE WARRANTIES AND REMEDIES CONTAINED HEREIN ARE IN LIEU OF AND EXCLUDE ALL OTHER WARRANTIES AND REMEDIES, WHETHER EXPRESS OR IMPLIED BY OPERATION OF LAW OR OTHERWISE, INCLUDING ANY WARRANTIES OF MERCHANTABILITY OR FITNESS FOR A PARTICULAR PURPOSE.**

Return Policy

If the equipment requires service, contact your Regional Service Center for a return authorization number (RA#). Equipment should be shipped prepaid to GAI-Tronics with a return authorization number and a purchase order number. If the equipment is under warranty, repairs or a replacement will be made in accordance with the warranty policy set forth above. Please include a written explanation of all defects to assist our technicians in their troubleshooting efforts.

Call 800-492-1212 (inside the USA) or 610-777-1374 (outside the USA) for help identifying the Regional Service Center closest to you.