



GAI-TRONICS®
A HUBBELL COMPANY



HUBBCOM™ GSC1100/GSC2100 Dual-Port DT/WM Smart Controller Quick Installation Guide

General Information



This guide covers the installation of the HUBBCOM Dual-Port Desktop/Wall-Mount Smart Controller, Models GSC1100 and GSC2100. The Model GSC1100 Smart Controller is equipped with a handset and is only suitable for horizontal (landscape) installations. The Model GSC2100 Smart Controller is not equipped with a handset and is suitable for vertical (portrait) or horizontal (landscape) use (see Figure 1). See the GAI-Tronics website at <https://www.gai-tronics.com> for system specifications, warranty information, and the GUDA (GAI-Tronics Universal Device Application).

Important Safety Instructions



- **Read, follow, and retain instructions**—All safety and operating instructions should be read and followed before operating the unit. Retain instructions for future reference.
- **Heed warnings**—Adhere to all warnings on the unit and in the operating instructions.
- **Attachments**—Attachments not recommended by the product manufacturer should not be used, as they may cause hazards.
- **Servicing**—Do not attempt to service this unit by yourself. Opening or removing covers may expose you to dangerous voltage or other hazards. Refer all servicing to qualified service personnel.
- HUBBCOM Smart Controllers are designed for indoor use only.

 **ATTENTION**  —Install equipment without modification and according to all applicable local, national, and international electrical codes. North America—Consult the National Electrical Code (NFPA 70), Canadian Standards Association (CSA 22.1), and local codes for specific requirements regarding your installation. Class 2 circuit wiring must be performed in accordance with the NEC.



These enclosures must be installed by trained, qualified and competent personnel. Installation must comply with state and national regulations, as well as safety practices for this type of equipment.

 **WARNING**  —Use only 24 V dc power supplies that conform to UL/CSA/CE Class II, Double Insulated supplies with over voltage and short circuit protection. Use only a dc source with a 50-watt maximum output or fuse the supply with a 2-amp fuse. EMI standards to Class B.

- **Onderhoud**—Probeer dit apparaat niet zelf te repareren. Het openen of verwijderen van afdekkingen kan u blootstellen aan gevaarlijke spanning of andere gevaren. Laat alle onderhoud over aan bevoegd onderhoudspersoneel.
- HUBBCOM Smart Controllers zijn alleen bedoeld voor gebruik binnenshuis.

 **AANDACHT**  —Gebruik alleen 24 VDC-voedingen die voldoen aan UL/CSA/CE Klasse II, dubbel geïsoleerde voedingen met overspanning en kortsluitbeveiliging. Gebruik alleen een DC-bron met een maximale output van 50 W of fuseer de voeding met een 2-ampère zekering. EMI-normen voor klasse B.

- **Dépannage**—N'essayez pas de réparer cet appareil vous-même. Ouvrir ou retirer les capots peut vous exposer à des tensions dangereuses ou à d'autres dangers. Confiez toute réparation à un personnel qualifié.
- Les contrôleurs intelligents HUBBCOM sont conçus pour une utilisation en intérieur uniquement.

 **ATTENTION**  —Utilisez uniquement des alimentations 24 Vcc conformes à UL/CSA/CE Classe II, des alimentations à double isolation avec protection contre les surtensions et les courts-circuits.

Utilisez uniquement une source cc avec une sortie maximale de 50 watts ou fusionnez l'alimentation avec un fusible de 2 ampères. Normes EMI à la classe B.

- **Manutenzione**—non tentare di riparare l'unità da soli. L'apertura o la rimozione dei coperchi potrebbero esporre a tensioni pericolose o altri rischi. Rivolgersi a personale qualificato per l'assistenza.
- Gli HUBBCOM Smart Controller sono progettati esclusivamente per uso interno.

! AVVERTIMENTO !

Utilizzare solo alimentatori a 24 V cc conformi a UL/CSA/CE Classe II, alimentatori a doppio isolamento con protezione da sovratensione e cortocircuito. Utilizzare solo una fonte di corrente continua con un'uscita massima di 50 watt o collegare l'alimentazione con un fusibile da 2 A. Standard EMI per la classe B.

- **Mantenimiento**—no intente reparar esta unidad por sí mismo. Abrir o quitar las cubiertas puede exponerlo a un voltaje peligroso u otros peligros. Remita todo el servicio a personal de servicio calificado.
- Los controladores inteligentes HUBBCOM están diseñados para uso en interiores solamente.

! ADVERTENCIA !

Utilice solo fuentes de alimentación de 24 V cc que cumplan con UL/CSA/CE Clase II, fuentes con doble aislamiento con sobretensión y protección contra cortocircuitos. Utilice solo una fuente de CC con una salida máxima de 50 vatios o fusione la fuente con un fusible de 2 amperios. Estándares EMI a Clase B.

Installation

The HUBBCOM Model GSC1100 and Model GSC2100 can be wall mounted or used as desktop units.

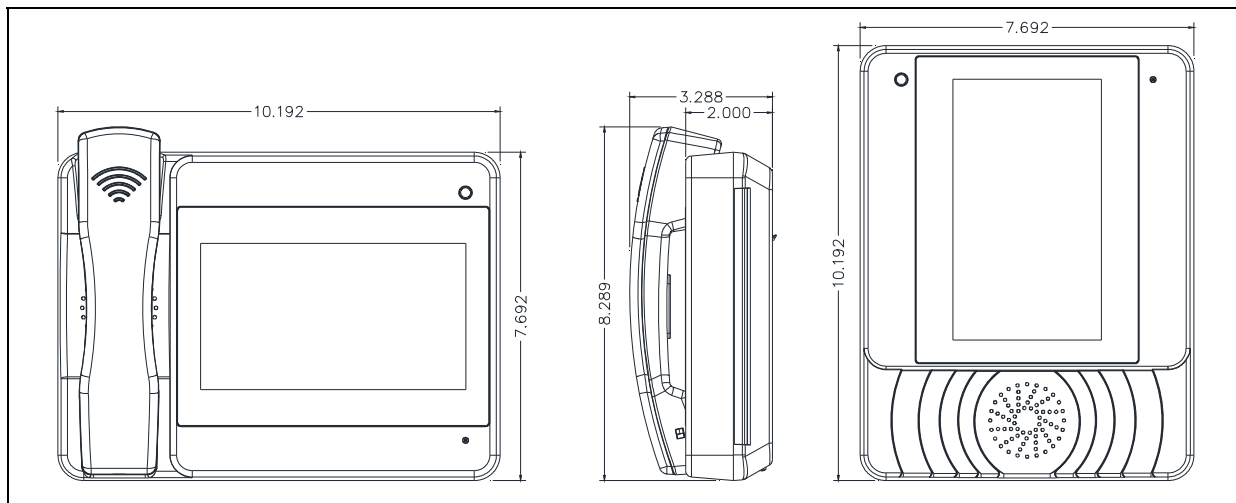

Figure 1. HUBBCOM Model GSC1100 (horizontal) and Model GSC2100 (vertical) Smart Controllers

Desktop Units

Use the HUBBCOM Smart Controller as a desktop station by installing the included kickstand (see Figure 2). Handset units must be setup horizontally. Hands-free units can be configured vertically or horizontally (based on programming).

1. Remove the cable termination cover and set it aside.
2. Complete the necessary cable terminations as described in the Wiring section.
3. Route the terminated wires through the half round access holes and secure with a tie wrap to the integrated anchors.
4. Replace the cable termination cover by hooking the two tabs into the slots and rotating the cover downward until it clicks into place.
5. Install the kickstand. The kickstand provides four positions in both orientations to suit the situation where it will be used (see Table 1 and Figure 4).
 1. Determine the orientation of the unit.
 2. Insert one side of the kickstand with the flange properly oriented into the desired position in the rear cutout (see Figure 4).
 3. Press the other side into place and compress firmly to snap it into place.

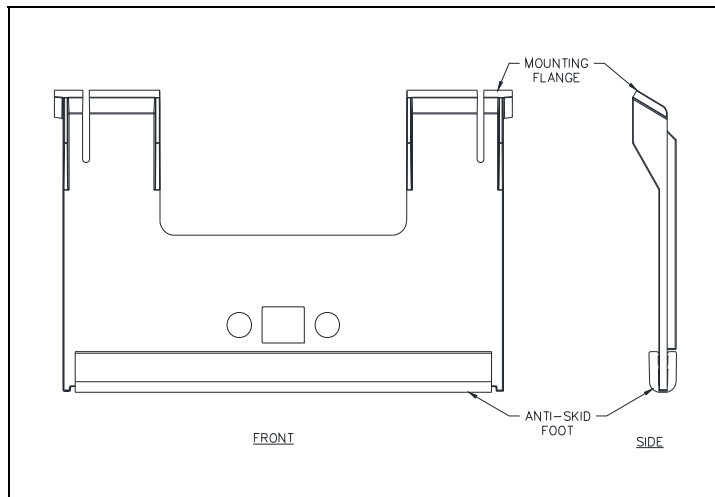

Figure 2. Smart Controller Kickstand

Table 1. Smart Controller Kickstand Positions

Orientation/ Position	Horizontal Models GSC1100 & GSC2100	Vertical Model GSC2100
1 (flange up)	75°	75°
2 (flange up)	60°	60°
2 (flange down)	45°	45°
3 (flange up)	30°	30°

Wall Mounting

HUBBCOM Smart Controllers can be wall mounted on a single or double gang electrical box or directly mounted to a wall surface using wall anchors or toggle bolts.

Single or double gang electrical box mounting:

1. Orient the wall-mount bracket (see Figure 3) over the electrical box with the small flanges on top and the large flanges on the bottom.
2. Use #8-32 flathead machine screws (not included) to attach the mounting bracket to the electrical box using holes A-A for a double gang (four screws), or B-B for a single gang electrical box (two screws).
3. Feed the cable(s) into the electrical box through the mounting bracket center hole.
4. Remove and discard the cable termination cover from the back of the unit.
5. Remove the two #8 × ½-inch mounting bracket screws from the bottom of the rear panel and set aside (see Figure 4).
6. Complete all necessary cable terminations (see the Wiring section).
7. With the proper orientation for the unit's configuration, angle the unit to hook it onto the top flange brackets (D-D or E-E, see Figure 4), then rotate and slide it downward until it rests on the mounting bracket.
8. Secure the unit to the support bracket using the two #8 × ½-inch screws previously removed by screwing them into the unit's chassis through the holes in the bottom flanges.

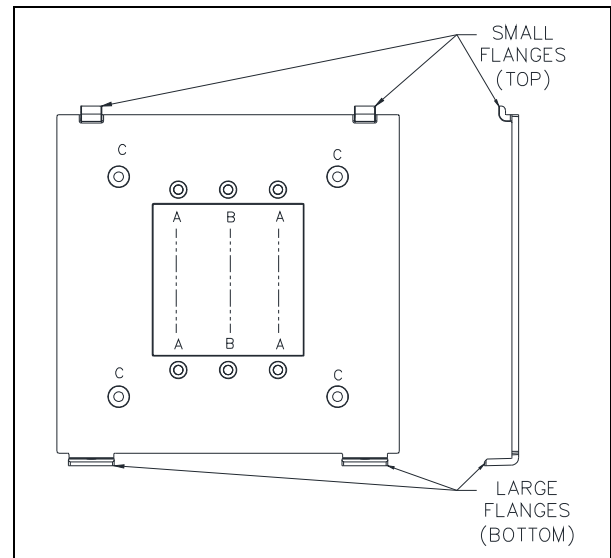

Figure 3. Smart Controller Wall-Mount Bracket

Surface mounting with toggle bolts or wall anchors:

1. Orient the support bracket on the wall with the small flanges on top and the large flanges on the bottom. Suggested mounting height is 48 inches from the floor to the bottom of the mounting bracket.
2. Mark the locations (C) for the four wall anchors or toggle bolts (not included) and the area in the center of the bracket where the cable(s) will come through the wall using the support bracket as a template (see Figure 3).
3. Drill the necessary holes for the toggle bolts or wall anchors and cut or drill a hole in the center area for the Smart Controller's cables.
4. Attach the mounting bracket to the wall using toggle bolts or wall anchors (not included).
5. Bring the cable(s) out through the support bracket center cutout.

6. Remove and discard the cable termination cover from the back of the unit.
7. Remove the two #8 × ½-inch mounting bracket screws from the bottom of the rear panel and set aside (see [Figure 4](#)).
8. Complete the necessary cable terminations per the instructions in the [Wiring](#) section below.
9. With the proper orientation for the unit's configuration, angle the unit to hook it onto the top flange brackets (D-D or E-E, see [Figure 4](#)), then rotate and slide it downward until it rests on the mounting bracket.
10. Secure the unit to the support bracket using the two #8 × ½-inch screws previously removed by screwing them up into the unit's chassis through the holes in the bottom flanges.

Wiring

HUBBCOM Smart Controllers are equipped with quick release terminal blocks that accept 18–24 AWG wires. Wires can be released from the terminal block by pressing the quick release button above the terminal.

NOTE: Two clamp on ferrite cores are supplied with the unit. Double wrap all wires terminating to terminal blocks TB1 and/or TB2 around a ferrite core. Install the clamp on ferrite cores as close as possible to the terminal blocks.

Handset

1. Plug the RJ12 handset connector into the RJ12 jack on the back of the unit.
2. **Wall-mount installations**—Tuck the handset cord into the channel to provide strain relief for the RJ12 plug.

RTU Input/Output

Terminal Block TB1 is for optional RTU I/O (Remote Terminal Unit Input/Output) functionality. Complete the following steps to terminate the RTU I/O cables:

1. Install appropriately sized ferrules onto the wire ends.
2. Install a clamp on ferrite core around all wires (double wrap) terminating to TB1 as close as possible to the terminal block.
3. Insert each wire into the correct quick release terminal (see [Table 2](#)).

RS-485 and External Speaker Connections

Terminal Block TB2 is for optional RS-485 and external speaker connections. Complete the following steps to terminate the RS-485 and external speaker connections:

NOTE: External 24 V dc power is required for stations with external speaker hook-ups.

1. Install appropriately sized ferrules onto the wire ends.
2. Install a clamp on ferrite core around all wires (double wrap) terminating to TB2 as close as possible to the terminal block.
3. Insert each wire into the correct quick release terminal (see [Table 3](#)).

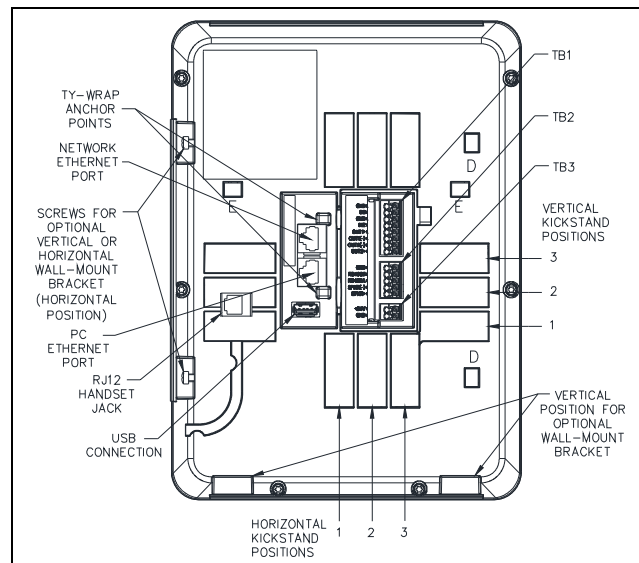

Figure 4. HUBBCOM Smart Controller—Rear View

Table 2. Terminal Block TB1—RTU I/O

Purpose	Term-Block Pin	Label
RTU Input One Ground	TB1-1	GND
RTU Input One	TB1-2	IN1
RTU Input Two Ground	TB1-3	GND
RTU Input Two	TB1-4	IN2
RTU Output One +	TB1-5	OUT1+
RTU Output 1 –	TB1-6	OUT1(-)
RTU Output 2 –	TB1-7	OUT2(-)
RTU Output 2 +	TB1-8	OUT2+

Table 3. Terminal Block TB2—RS-485 and External Speaker

Purpose	Term-Block Pin	Label
RS485 Ground	TB2-1	GND
RS485 B	TB2-2	RS485B
RS485 A	TB2-3	RS485A
External Speaker –	TB2-4	SPKR-
External Speaker +	TB2-5	SPKR+

Ethernet

HUBBCOM Smart Controllers are equipped with dual Ethernet ports. Use the port furthest from the USB port to connect to the Ethernet network. The port closest to the USB port can be used to connect a PC (see Figure 4).

1. Plug the Ethernet cable from the network into the RJ45 port furthest from the USB port.
2. (Optional) Plug an Ethernet cable from a PC into the remaining RJ45 jack(see Figure 4).

24 V DC Power

24 V dc power can be used in place of POE and must be used for units requiring an external speaker hook-up. Complete the following steps to terminate the 24 V dc power source to the smart controller:

1. Install ferrules onto the wire ends.
2. Insert each wire into the correct quick release terminal (see Table 4).

Table 4. Terminal Block TB3—24 V DC Power

Purpose	Term-Block Pin	Label
24 V dc Positive	TB3-1	+24V
Ground	TB3-2	GND

Antenna

An SMA (Sub-Miniature connector A) coaxial connector is provided for an antenna connection.

NOTE: The secondary Ethernet port is not functional when the HUBBCOM station is connected via WiFi.

NOTE: The antenna used in flush-mount installations is customer-supplied. FCC, IC, ETSI/CE, and TELEC Certified with PCB, Dipole, Chip, and PIFA Antennae. GAI-Tronics Kit No. 12840-001 (purchased separately) meets the antenna requirements.

Activation

HUBBCOM devices require activation the first time they are energized and after any purchased upgrades are installed. The devices can be activated with or without the presence of a DHCP server.

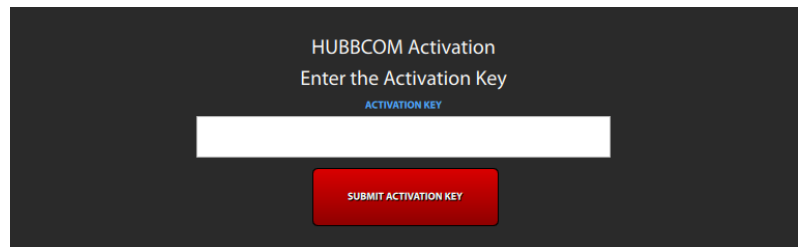

Figure 5. HUBBCOM Device Activation Screen

Activation with DHCP

1. Complete all installation steps for the HUBBCOM device.
2. Apply power to the HUBBCOM device. The HUBBCOM device takes 40–50 seconds to boot to the device activation screen (see Figure 5). The screen may flicker several times during boot-up.
3. Touch the screen in the ACTIVATION KEY field to display the onscreen keyboard.
4. Enter the device key provided on the device’s activation label (see Figure 6 and Figure 7).
5. Press the SUBMIT ACTIVATION KEY button on the screen (see Figure 7).



Figure 6. Device Activation Label

The HUBBCOM device will reboot to activate. The device takes 40–50 seconds to reboot. The screen may flicker several times during boot-up.

Upon reboot: devices with the telephone option will display the DEVICE CONFIGURATION INCOMPLETE screen (see Figure 8); devices without the telephone option will boot to the home screen.

6. Use the GUDA (GAI-Tronics Universal Device Application) to complete the software configuration of the HUBBCOM device.

The GUDA is available on GAI-Tronics’ website at www.GAI-TRONICS.com.

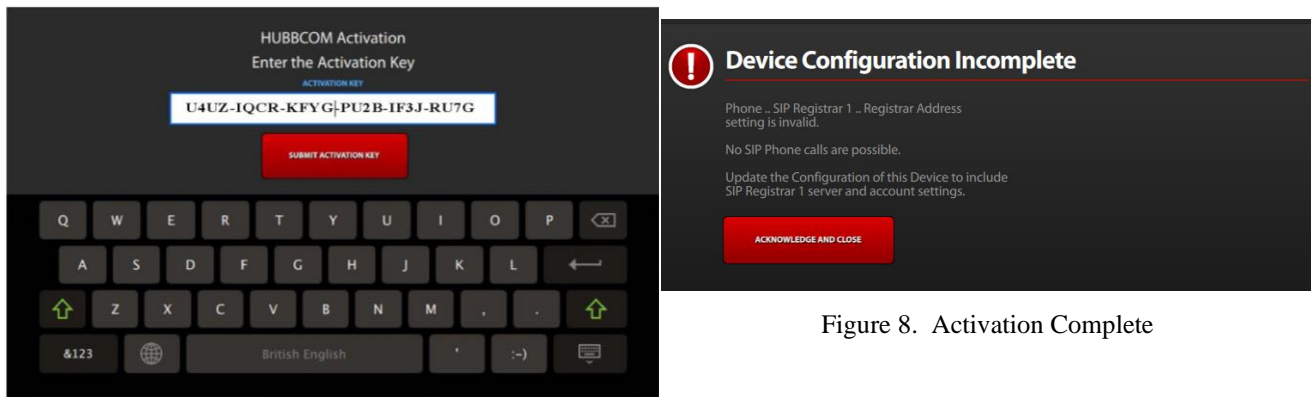

Figure 7. Device License Key Entered

Figure 8. Activation Complete

Activation without DHCP

Activate HUBBCOM stations on a network without a DHCP server as follows:

1. Connect the HUBBCOM station to the network.
2. Apply power to the station.
 - The station displays the HUBBCOM splash screen but does not continue to the activation screen.
 - The unit assigns itself an APIPA (automatic private IP address) after approximately one minute.
3. Configure a PC, with the GUDA installed, for DHCP or manually assign a static IP address in the APIPA range.
 - A PC configured for DHCP will assign itself an APIPA after approximately one to two minutes.
 - A PC configured with a static IP address in the APIPA range will boot normally.
4. Run the GUDA software.
5. Select the PC's APIPA assigned network interface from the **SELECT NETWORK INTERFACE** dropdown list.
6. Click the **FIND DEVICES** button to perform a device discovery in the GUDA.
An **ICON** for the new HUBBCOM station is displayed when the PC can connect to it.
7. Click on the **ICON** for the HUBBCOM station.
8. Click the **CONNECT AND CONFIGURE** button for the HUBBCOM station.
9. Login:
 - Username: *gai-tronics*
 - Password: *pageparty*
10. Create a new username and password.
11. Login to the HUBBCOM station with the new username and password.
12. Scroll down in the left pane and click on **ACTIVATION**.
13. Enter the unit's activation code on the activation screen.
14. Click the **APPLY** button to confirm the activation code.
A **REBOOT** button appears next to the **APPLY** button.
15. Click **REBOOT** and confirm it.
The unit will reboot and will display the HUBBCOM splash screen again.
16. Verify the unit is activated and the model number is correct.
 1. Click the **Menu** button.
 2. Click the **Settings** button.
 - The model is shown on the left side above the volume controls.
 - The model will show **NOT SPECIFIED** if the unit is not activated.
17. Connect additional HUBBCOM stations to the network and repeat the procedure to activate and configure them.

NOTE: Enter additional station parameters while activating the unit to save time. All entered parameters are configured regardless of correct activation code entry. Changing the network parameters of a HUBBCOM station will prevent the PC from connecting to the unit until the PC's IP address is on the same subnet as that unit.

Service and Spare Parts

Contact a regional service center for assistance if the equipment requires service or spare parts. An RA# (return authorization number) will be issued if service is required. Equipment must be shipped prepaid to GAI-Tronics with a return authorization number and a purchase order number. Repairs or a replacement will be made in accordance with GAI-Tronics' warranty policy if the equipment is under warranty. Please include a written explanation of all defects to assist our technicians in their troubleshooting efforts. Call 800-492-1212 inside the USA or 610-777-1374 outside the USA for help with identifying the nearest regional service center.

Specifications

Wi-Fi operating frequency range 2.412–2.462 GHz
 Temperature Range..... 32 °F–122 °F (0 °C–50 °C)

Approvals

Compliance to Standard

CE

EMC emissions to Class B..... EN55032/FCC Part15B/ICES-003

ImmunityEN55035

Assessment risk of exposureEN62311

Product Safety Assessment UL/IEC62368-1

Contains FCC ID: Z64-WL18DBMOD and IC: 4511-WL18DBMOD

NOTE: This equipment has been tested and found to comply with the limits for a Class B digital device, pursuant to part 15 of the FCC Rules. These limits are designed to provide reasonable protection against harmful interference in a residential installation. This equipment generates, uses, and can radiate radio frequency energy and, if not installed and used in accordance with the instructions, may cause harmful interference to radio communications. However, there is no guarantee that interference will not occur in a particular installation. If this equipment does cause harmful interference to radio or television reception, which can be determined by turning the equipment off and on, the user is encouraged to try to correct the interference by one or more of the following measures:

- Reorient or relocate the receiving antenna.
- Increase the separation between the equipment and receiver.
- Connect the equipment into an outlet on a circuit different from that to which the receiver is connected.
- Consult the dealer or an experienced radio/TV technician for help.

Warranty

Equipment. GAI-Tronics warrants for a period of one (1) year from the date of shipment, that any GAI-Tronics equipment supplied hereunder shall be free of defects in material and workmanship, shall comply with the then-current product specifications and product literature, and if applicable, shall be fit for the purpose specified in the agreed-upon quotation or proposal document. If (a) Seller's goods prove to be defective in workmanship and/or material under normal and proper usage, or unfit for the purpose specified and agreed upon, and (b) Buyer's claim is made within the warranty period set forth above, Buyer may return such goods to GAI-Tronics' nearest depot repair facility, freight prepaid, at which time they will be repaired or replaced, at Seller's option, without charge to Buyer. Repair or replacement shall be Buyer's sole and exclusive remedy. The warranty period on any repaired or replacement equipment shall be the greater of the ninety (90) day repair warranty or one (1) year from the date the original equipment was shipped. In no event shall GAI-Tronics warranty obligations with respect to equipment exceed 100% of the total cost of the equipment supplied hereunder. Buyer may also be entitled to the manufacturer's warranty on any third-party goods supplied by GAI-Tronics hereunder. The applicability of any such third-party warranty will be determined by GAI-Tronics.

Services. Any services GAI-Tronics provides hereunder, whether directly or through subcontractors, shall be performed in accordance with the standard of care with which such services are normally provided in the industry. If the services fail to meet the applicable industry standard, GAI-Tronics will re-perform such services at no cost to buyer to correct said deficiency to Company's satisfaction provided any and all issues are identified prior to the demobilization of the Contractor's personnel from the work site. Re-performance of services shall be Buyer's sole and exclusive remedy, and in no event shall GAI-Tronics warranty obligations with respect to services exceed 100% of the total cost of the services provided hereunder.

Warranty Periods. Every claim by Buyer alleging a defect in the goods and/or services provided hereunder shall be deemed waived unless such claim is made in writing within the applicable warranty periods as set forth above. Provided, however, that if the defect complained of is latent and not discoverable within the above warranty periods, every claim arising on account of such latent defect shall be deemed waived unless it is made in writing within a reasonable time after such latent defect is or should have been discovered by Buyer.

Limitations / Exclusions. The warranties herein shall not apply to, and GAI-Tronics shall not be responsible for, any damage to the goods or failure of the services supplied hereunder, to the extent caused by Buyer's neglect, failure to follow operational and maintenance procedures provided with the equipment, or the use of technicians not specifically authorized by GAI-Tronics to maintain or service the equipment. **THE WARRANTIES AND REMEDIES CONTAINED HEREIN ARE IN LIEU OF AND EXCLUDE ALL OTHER WARRANTIES AND REMEDIES, WHETHER EXPRESS OR IMPLIED BY OPERATION OF LAW OR OTHERWISE, INCLUDING ANY WARRANTIES OF MERCHANTABILITY OR FITNESS FOR A PARTICULAR PURPOSE.**

Return Policy

If the equipment requires service, contact your Regional Service Center for a return authorization number (RA#). Equipment should be shipped prepaid to GAI-Tronics with a return authorization number and a purchase order number. If the equipment is under warranty, repairs or a replacement will be made in accordance with the warranty policy set forth above. Please include a written explanation of all defects to assist our technicians in their troubleshooting efforts.

Call 800-492-1212 (inside the USA) or 610-777-1374 (outside the USA) for help identifying the Regional Service Center closest to you.