



**GAI-TRONICS®**  
A HUBBELL COMPANY

# HUBBCOM™ GSC3100/GSC4100 Dual-Port Flush-Mount Smart Controller Quick Installation Guide



---

## General Information



This guide covers the installation of the HUBBCOM™ Dual-Port Flush-Mount Smart Controller, Models GSC3100 and GSC4100. The Model GSC3100 Smart Controller is equipped with a handset. The Model GSC4100 Smart Controller is designed for hands-free operation and is not equipped with handset (see Figure 1). See the GAI-Tronics website at <https://www.gai-tronics.com> for system specifications, warranty information, and the GUDA (GAI-Tronics Universal Device Application).

## Important Safety Instructions

- Read, follow, and retain instructions—All safety and operating instructions should be read and followed before operating the unit. Retain instructions for future reference.
- Heed warnings—Adhere to all warnings on the unit and in the operating instructions.
- Attachments—Attachments not recommended by the product manufacturer should not be used, as they may cause hazards.
- Servicing—Do not attempt to service this unit by yourself. Opening or removing covers may expose you to dangerous voltage or other hazards. Refer all servicing to qualified service personnel.
- Hubbcom™ Smart Controllers are designed for indoor use only.

 **ATTENTION**  —Install equipment without modification and according to all applicable local, national, and international electrical codes. North America - Consult the National Electrical Code (NFPA 70), Canadian Standards Association (CSA 22.1), and local codes for specific requirements regarding your installation. Class 2 circuit wiring must be performed in accordance with NEC 725.55.

These enclosures must be installed by trained, qualified and competent personnel. Installation must comply with state and national regulations, as well as safety practices for this type of equipment.

 **WARNING**  —Use only 24 V dc power supplies that conform to UL/CSA/CE Class II, Double Insulated supplies with over voltage and short circuit protection. Use only a dc source with a 50-watt maximum output or fuse the supply with a 2-amp fuse. EMI standards to Class B.

## Security Hardware

The HUBBCOM™ Smart Controllers described in this manual are vandal resistant. The front panel of each smart controller is attached to its enclosure with security screws. A GAI-Tronics Model 233-001 Security Screwdriver or Torx T-25 security head tip (sold separately) is required for installing the telephone.

## Installation

HUBBCOM™ Flush-Mount Smart Controllers can be flush mounted in a wall or stanchion using the included backbox or surface mounted using a GAI-Tronics Model 236 Series or Model 238-001 Stainless-Steel Surface-Mount Enclosure (sold separately).

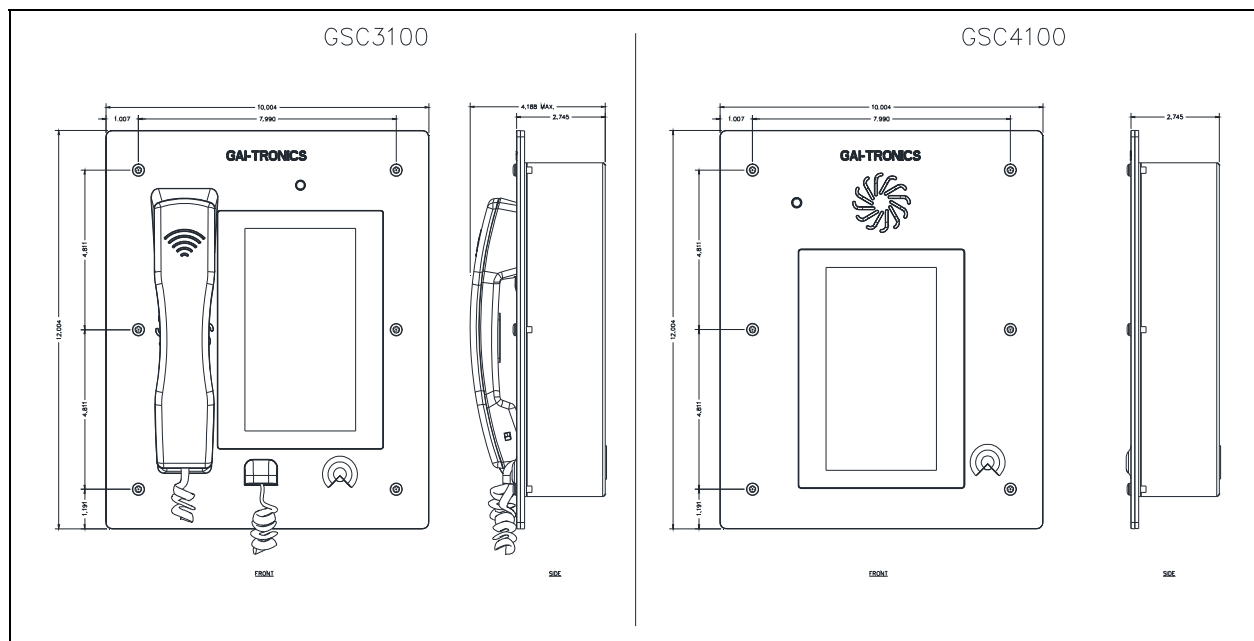

Figure 1. HUBBCOM™ Model GSC3100 and Model GSC4100 Smart Controllers

### Stanchion and Flush-Mount Installation

The supplied back box must be used when mounting the HUBBCOM™ Smart Controller in a GAI-Tronics Model 234 Series Stanchion and for flush mount installations:

1. Remove the backbox from the Smart Controller by removing the six #10-32 security screws and washers holding them together.
2. Remove a tapered plug from one of the rear cable entry holes in the backbox.
3. Install a cable strain relief cable fitting to the box.
4. Feed the Ethernet cable and all additional cables through the cable fitting.
5. Mount the back box to the structure using appropriate hardware (see Figure 3 for cutout dimensions).
6. Complete all necessary cable terminations (see the Wiring section).

**NOTE:** Two clamp on ferrite cores are supplied with the unit. Install a ferrite core around all wires terminating to terminal blocks TB1 and/or TB2. Attach the clamp on ferrite cores as close as possible to the terminal block.

7. Secure the unit to the backbox mounting flanges using the six security screws with washers removed in Step 1.
8. Tighten the screws to 10–12 in-lb.

### Surface Mount Installations with GAI-Tronics Model 236 Series or Model 238-001 Enclosure

1. Refer to Pub. 42004-285 for the Model 236 Series or Pub. 42004-434 for the Model 238-001 backboxes to install the surface-mount enclosure. GAI-Tronics publications are located on the GAI-Tronics website at <https://www/gai-tronics.com>.
2. Remove and discard the backbox installed on the Smart Controller by removing the six security screws and washers. Retain the six security screws and washers.
3. Complete all necessary cable terminations (see the Wiring section).

**NOTE:** Two clamp on ferrite cores are supplied with the unit. Install a ferrite core around all wires terminating to terminal blocks TB1 or TB2. Attach the clamp on ferrite cores as close as possible to the terminal block.

4. Secure the unit to the surface-mount enclosure using the six security screws and washers removed in Step 2.
5. Tighten the screws to 10–12 in-lb.

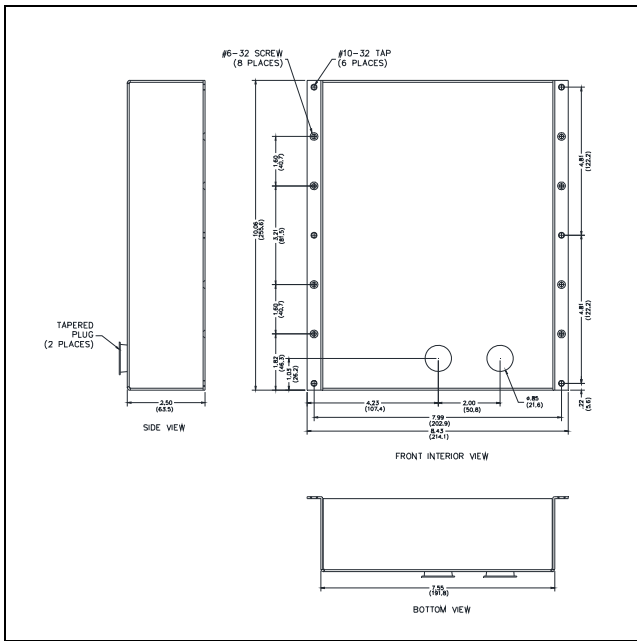

Figure 2. Flush-Mount Smart Controller Back Box Mounting Details

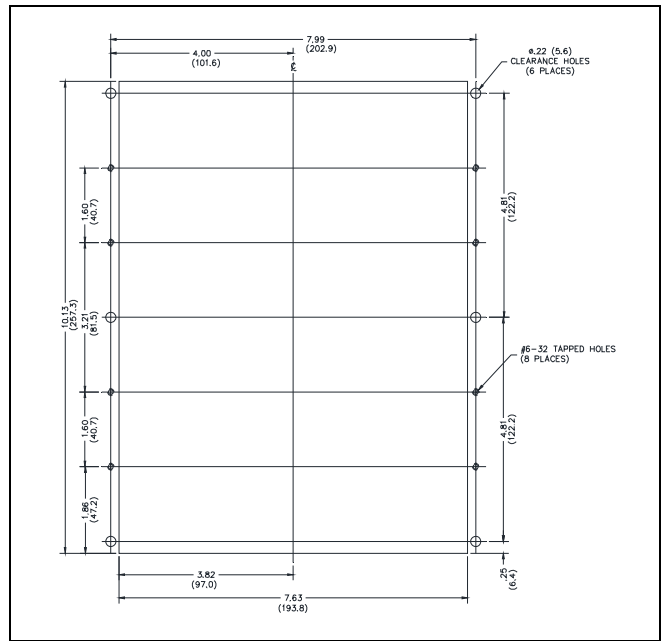

Figure 3. Flush-Mount Cutout Details

Wiring

Hubbcom™ Smart Controllers are equipped with quick release terminal blocks that accept 18–24 AWG wires. Wires can be released from the terminal block by pressing the quick release button above the terminal.

RTU Input/Output

Terminal Block TB1 is for optional RTU I/O (Remote Terminal Unit Input/Output) functionality. Complete the following steps to terminate the RTU I/O cables:

1. Install appropriately sized ferrules onto the wire ends.
2. Install a clamp on ferrite core around all wires terminating to TB1 as close as possible to the terminal block.
3. Insert each wire into the correct quick release terminal (see Table 1).

Table 1. Terminal Block TB1—RTU I/O

Purpose	Term Block-Pin	Label
RTU Input One Ground	TB1-1	GND
RTU Input One	TB1-2	IN1
RTU Input Two Ground	TB1-3	GND
RTU Input Two	TB1-4	IN2
RTU Output 1 +	TB1-5	OUT1+
RTU Output 1 –	TB1-6	OUT1(-)
RTU Output 2 –	TB1-7	OUT2(-)
RTU Output 2 +	TB1-8	OUT2+

RS-485 and External Speaker Connections

Terminal Block TB2 is for optional RS-485 and external speaker connections. Complete the following steps to terminate the RS-485 and external speaker connections

**NOTE:** External 24 V dc power is required for stations with external speaker hook-ups.

1. Install appropriately sized ferrules onto the wire ends.
2. Install a clamp on ferrite core around all wires terminating to TB2 as close as possible to the terminal block.
3. Insert each wire into the correct quick release terminal (see Table 2).

Table 2. Terminal Block TB2—RS-485 and External Speaker

Purpose	Term Block-Pin	Label
RS485 Ground	TB2-1	GND
RS485 B	TB2-2	RS485B
RS485 A	TB2-3	RS485A
External Speaker –	TB2-4	SPKR–
External Speaker +	TB2-5	SPKR+

**Ethernet**

The Hubbcom™ Smart Controllers are equipped with two Ethernet ports. The port furthest from the USB port must be used to connect to the Ethernet network. The port closest to the USB port can be used to connect a PC.

1. Plug the Ethernet cable from the network into the RJ45 port furthest from the USB port.
2. (Optional) Plug an Ethernet cable from a PC into the remaining RJ45 jack.

**24 V DC Power**

24 V dc power can be used in place of POE and must be used for units requiring an external speaker hook-up. Complete the following steps to terminate the 24 V dc power source to the access panel:

1. Install appropriately sized ferrules onto the wire ends.
2. Insert each wire into the correct quick release terminal (see Table 3).

Table 3. 24 V DC Power

Purpose	Term-Block Pin	Label
24 V dc Positive	TB3-1	+24V
Ground	TB3-2	GND

**Antenna**

An SMA (Sub-Miniature connector A) coaxial connector is provided for an antenna connection.

**NOTE:** The secondary Ethernet port is not functional when the Hubbcom station is connected via WiFi.

**NOTE:** The antenna used in flush-mount installations is customer-supplied. FCC, IC, ETSI/CE, and TELEC Certified with PCB, Dipole, Chip, and PIFA Antennae. GAI-Tronics Kit No. 12840-001 (purchased separately) meets the antenna requirements.

**Service and Spare Parts**

Contact a Regional Service Center for assistance if the equipment requires service or spare parts. A return authorization number (RA#) will be issued if service is required. Equipment must be shipped prepaid to GAI-Tronics with a return authorization number and a purchase order number. Repairs or a replacement will be made in accordance with GAI-Tronics' warranty policy if the equipment is under warranty. Please include a written explanation of all defects to assist our technicians in their troubleshooting efforts. Call 800-492-1212 inside the USA or 610-777-1374 outside the USA for help with identifying the Regional Service Center closest to you.

**Specifications**

Wi-Fi operating frequency range ..... 2.412–2.462 GHz (US)  
 Temperature Range ..... 32–122 °F (0–50 °C)

**Approvals**

Compliance to Standard ..... FCC CFR 47 Part 15 Class A  
 FCC ID: Z64-WL18DBMOD  
 IC: 4511-WL18DBMOD

**NOTE:** This equipment has been tested and found to comply with the limits for a Class A digital device, pursuant to part 15 of the FCC Rules. These limits are designed to provide reasonable protection against harmful interference when the equipment is operated in a commercial environment. This equipment generates, uses, and can radiate radio frequency energy; and, if not installed and used in accordance with the instruction manual, may cause harmful interference to radio communications. Operation of this equipment in a residential area is likely to cause harmful interference in which case the user will be required to correct the interference at their own expense.

# Warranty

---

Equipment. GAI-Tronics warrants for a period of one (1) year from the date of shipment, that any GAI-Tronics equipment supplied hereunder shall be free of defects in material and workmanship, shall comply with the then-current product specifications and product literature, and if applicable, shall be fit for the purpose specified in the agreed-upon quotation or proposal document. If (a) Seller's goods prove to be defective in workmanship and/or material under normal and proper usage, or unfit for the purpose specified and agreed upon, and (b) Buyer's claim is made within the warranty period set forth above, Buyer may return such goods to GAI-Tronics' nearest depot repair facility, freight prepaid, at which time they will be repaired or replaced, at Seller's option, without charge to Buyer. Repair or replacement shall be Buyer's sole and exclusive remedy. The warranty period on any repaired or replacement equipment shall be the greater of the ninety (90) day repair warranty or one (1) year from the date the original equipment was shipped. In no event shall GAI-Tronics warranty obligations with respect to equipment exceed 100% of the total cost of the equipment supplied hereunder. Buyer may also be entitled to the manufacturer's warranty on any third-party goods supplied by GAI-Tronics hereunder. The applicability of any such third-party warranty will be determined by GAI-Tronics.

Services. Any services GAI-Tronics provides hereunder, whether directly or through subcontractors, shall be performed in accordance with the standard of care with which such services are normally provided in the industry. If the services fail to meet the applicable industry standard, GAI-Tronics will re-perform such services at no cost to buyer to correct said deficiency to Company's satisfaction provided any and all issues are identified prior to the demobilization of the Contractor's personnel from the work site. Re-performance of services shall be Buyer's sole and exclusive remedy, and in no event shall GAI-Tronics warranty obligations with respect to services exceed 100% of the total cost of the services provided hereunder.

Warranty Periods. Every claim by Buyer alleging a defect in the goods and/or services provided hereunder shall be deemed waived unless such claim is made in writing within the applicable warranty periods as set forth above. Provided, however, that if the defect complained of is latent and not discoverable within the above warranty periods, every claim arising on account of such latent defect shall be deemed waived unless it is made in writing within a reasonable time after such latent defect is or should have been discovered by Buyer.

Limitations / Exclusions. The warranties herein shall not apply to, and GAI-Tronics shall not be responsible for, any damage to the goods or failure of the services supplied hereunder, to the extent caused by Buyer's neglect, failure to follow operational and maintenance procedures provided with the equipment, or the use of technicians not specifically authorized by GAI-Tronics to maintain or service the equipment. **THE WARRANTIES AND REMEDIES CONTAINED HEREIN ARE IN LIEU OF AND EXCLUDE ALL OTHER WARRANTIES AND REMEDIES, WHETHER EXPRESS OR IMPLIED BY OPERATION OF LAW OR OTHERWISE, INCLUDING ANY WARRANTIES OF MERCHANTABILITY OR FITNESS FOR A PARTICULAR PURPOSE.**

## Return Policy

---

If the equipment requires service, contact your Regional Service Center for a return authorization number (RA#). Equipment should be shipped prepaid to GAI-Tronics with a return authorization number and a purchase order number. If the equipment is under warranty, repairs or a replacement will be made in accordance with the warranty policy set forth above. Please include a written explanation of all defects to assist our technicians in their troubleshooting efforts.

Call 800-492-1212 (inside the USA) or 610-777-1374 (outside the USA) for help identifying the Regional Service Center closest to you.