



GAI-TRONICS®  
A HUBBELL COMPANY

# 703-002 7325-102 and 7335-002— 24 V DC Multi-Party Amplifier Enclosures

---

## Confidentiality Notice

This manual is provided solely as an installation, operation, and maintenance guide and contains sensitive business and technical information that is confidential and proprietary to GAI-Tronics. GAI-Tronics retains all intellectual property and other rights in or to the information contained herein, and such information may only be used in connection with the operation of your GAI-Tronics product or system. This manual may not be disclosed in any form, in whole or in part, directly or indirectly, to any third party.

The following are trademarks of GAI-Tronics Corporation:

SmartSeries®

Page/Party®

ADVANCE

SmartVolume™

## General Information

This manual applies to the following GAI-Tronics amplifier enclosures:



Model	Description
703-002	Indoor Amplifier Enclosure; multi-party, 24 V dc input
7325-102	Weatherproof Aluminum Enclosure; multi-party, 24 V dc input
7335-002	Weatherproof Non-metallic Amplifier Enclosure; multi-party, 24 V dc input

The amplifier enclosure is an important component of the 700 Series Page/Party system. These enclosures are configured for multi-party systems and can accommodate conversations on up to five party lines simultaneously.

The Model 703-002 Indoor Amplifier Enclosure is constructed of fabricated steel. The Model 7325-102 Outdoor Enclosure is made of cast aluminum alloy, and the Model 7335-002 Outdoor Enclosure is made of glass-reinforced polyester. Both outdoor enclosures are extremely weatherproof and corrosion resistant.

These enclosures are equipped with terminal strips for connecting inter-station cable. The 701 and 751 Series Amplifiers mate directly with these enclosures.

## Installation

 **CAUTION**  —Do not install this equipment in hazardous areas or areas other than those indicated on the approval listing in the Specifications section of this manual. Such installation may cause a safety hazard and consequent injury or property damage.



When installing an add-on station, consult the 24 V dc system layout diagrams at the end of this manual. These figures, when used in conjunction with the station installation information and cable layout guide, should provide all the information necessary to install additional Page/Party® stations.

In 24-volt systems, plan on several branch lines from the dc source with no more than six stations per branch. One branch could span up to 4,000 feet for a single station. The Maximum Cable Distance Table lists the limits. Where two or more stations are listed, the assumption is that they are evenly spaced along the cable.

Each amplifier contains two fuses on the PCBA in the 24 V dc input to protect and isolate the handset and speaker amplifier circuitry in the event of a failure. Power line wiring to each amplifier or group of amplifiers should have a fuse or circuit breaker to protect against wiring failures.

If cable with No. 14 AWG power line conductors is used, a 15-amp fuse or circuit breaker should be installed for each branch line at the point it connects to the battery. Fuse or circuit breaker rating is determined by the size cable used in the branch. Consult the National Electrical Code (NFPA70) or Canadian Standards Association (CSA 22.1) for the maximum allowable capacity of the wire used.

The GAI-Tronics 24 V dc series of Page/Party system equipment is designed to operate from a 24-volt dc rechargeable battery. A battery charger may be connected to the battery to maintain the charge.

 **CAUTION**  —Under NO condition should this equipment be operated from a battery charger without the batteries connected.

Most chargers have an unloaded output of 35 to 45 volts that can quickly damage the equipment designed for nominal 24 volts. To maintain a proper state of battery charge, the voltage across the batteries will be somewhat greater than 24 volts but should never exceed 28.8 V dc. Grounding the negative side of the battery system at only one point is recommended and will ensure hum- and noise-free operation.

## Enclosure Placement

All GAI-Tronics Page/Party units are wired in parallel. Good system layout design minimizes the cable required for each installation. GAI-Tronics multi-conductor cable, designed especially for this application, is recommended. The number, size, and color-coding of conductors are listed in the accompanying system connection diagrams.

System layout and power cable length are important considerations when installing Page/Party equipment. Consult the Maximum Cable Distance table for typical cable lengths. The cable distance between stations as well as total cable distance must be considered. Cable distance is more strictly regulated in 24 V dc systems because of the amount of resistance these cables encounter—the longer the cable distance, the greater the resistance and IR losses (voltage drop) encountered.

## Maximum Cable Distance in Feet\*

Number of Units	No. 14 AWG Total / Between	No. 12 AWG Total / Between	No. 10 AWG Total / Between	No. 8 AWG Total / Between
1	977 / 977	1,554 / 1,554	2,471 / 2,471	3,931 / 3,931
2	651 / 325	1,037 / 518	1,648 / 824	2,620 / 1,310
3	489 / 163	777 / 259	1,236 / 412	1,966 / 655
4	391 / 98	622 / 155	988 / 247	1,572 / 393
5	325 / 65	518 / 103	823 / 165	1,310 / 262
6	279 / 46	444 / 74	706 / 117	1,123 / 187
9	196 / 21	311 / 34	494 / 55	786 / 87

\*Based on the following assumptions:

- Continuous tone (alarm) signals driving each station's speaker amp to a maximum of 12 watts.

**NOTE:** If the station is used for speech (audio) signals only, the distances stated above can be multiplied by a factor of 2 because speech signals do not have the energy content that a continuous tone has; therefore, they do not require as much average current and thus less cable IR drop will result.

- GAI-Tronics-supplied cable is used.
- Wire resistance (ohms) is the nominal value for the applicable AWG at 1,000 feet of bare copper, stranded wire @ 20° C (68° F). Wire resistance values used are as follows:  
No. 14 AWG = ~2.525 ohms; No. 12 AWG = ~1.588 ohms; No. 10 AWG = ~0.999 ohm; No. 8 AWG = ~0.628 ohm
- DC V at cable run's feed point (Float charge of connected batteries) = ~26.6 V dc
- DC V at the last unit in cable run = 21 V dc minimum
- Station unit current draw (I) is the same regardless of the unit's placement along the cable run for ease of calculation. (1.1 amperes when unit is producing a 12-watt sine wave output.)
- Distances reflect a 3% reduction for margin of error.

For conditions other than above, the following formula may be helpful in calculating the approximate maximum distance for a SINGLE station.

For **CONTINUOUS** tone applications with minimum distortion:

$$\frac{V_{\text{FEEDPOINT}} - V_{\text{MINIMUM}}}{(2 \times \text{AWG WIRE RESISTANCE PER FOOT @ } \sim 20^{\circ}\text{C}) \times \text{UNIT I [IN AMPS @ } 12\text{W OUT]}} = \text{APPROXIMATE MAXIMUM DISTANCE IN FEET}$$

For **SPEECH** operation only, multiply the above result by a factor of 2.

**Example:** What is the approximate maximum distance for a **single** dc station if the voltage feed is 27.5 V dc and a No. 14 AWG wire is used @ 20° C?

Info:

- No. 14 AWG @ 20° C = ~0.002525 ohm per foot × 2 for LOOP R
- $V_{\text{FEEDPOINT}} = 27.5 \text{ V dc}$



For specific details including mounting hole dimensions, refer to Figure 1 for the Model 703-002 Indoor Enclosure, Figure 2 for Model 7335-002 Weatherproof Non-metallic Enclosure, and Figure 3 for the Model 7325-102 Weatherproof Metallic Enclosure. When mounting the enclosure, use caution to avoid damaging the terminal blocks inside. The suggested mounting height for all station enclosures is 54 inches (137 cm) up to the centerline of the enclosure.

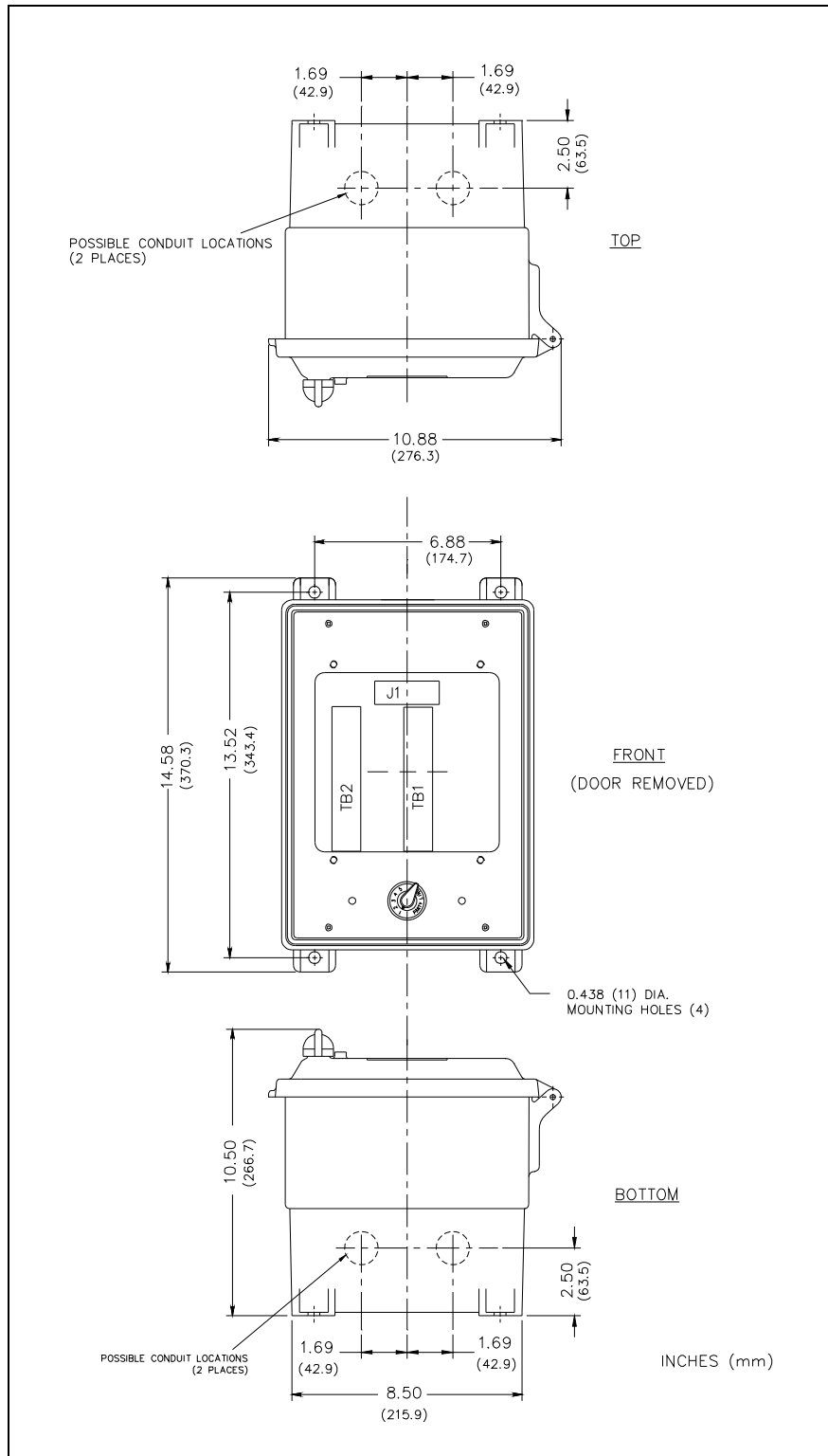

Figure 2. Model 7335-002 Outdoor Enclosure Mounting Details

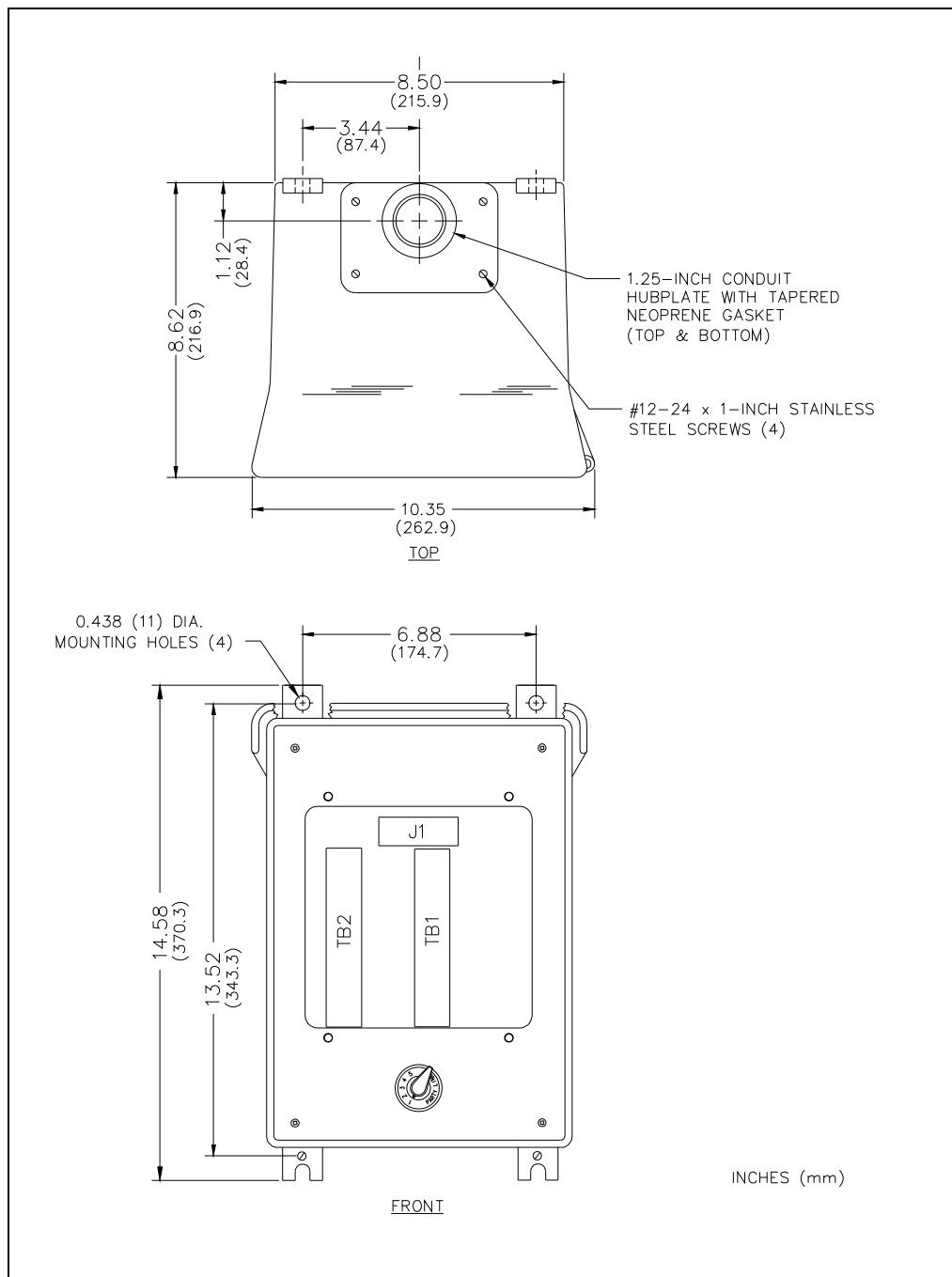

Figure 3. Model 7325-102 Weatherproof Aluminum Enclosure Mounting Details

## Wiring

Attach conduit to the enclosure. Feed the wiring through the conduit and bring it into the enclosure. See Figure 4. Follow the wire colors carefully, because the colors correspond to GAI-Tronics 60029 Series multi-party cable. The wires must be spade-lugged and connected carefully and completely to the terminal block. An improper termination may diminish station performance.

## Local Muting

Figure 4 illustrates local speaker muting when stations are completely assembled and paging operation occurs. Normally, when the station button is pressed, the paging speaker connected to that station is

silenced (muted) to prevent acoustic feedback to the handset microphone. However, while the handset is in use for party line conversations, the paging speaker is “live” to enable paging calls from other stations.

To disable the mute feature, follow these instructions:

1. Locate the lugged violet wire attached to terminal point 7 (Mute) on the terminal block within the enclosure.
2. Transfer the lugged violet wire to terminal point 8 (Page L1).

After any muting changes are made, unpack the station amplifier and install.

### Mutual Muting

If feedback occurs within an area and repositioning of the system speakers does not help, mutual muting may be used to correct this problem. The following steps mutually mute adjacent amplifiers/handsets within a zone:

1. Ensure that the purple lugged wire is connected to terminal 7 of TB1.
2. Connect terminal TB1-7 of the handset station to TB1-7 of the station within the zone that is causing feedback. This is done by using the spare system wire (orange conductor) from within the system cable that runs between the stations.

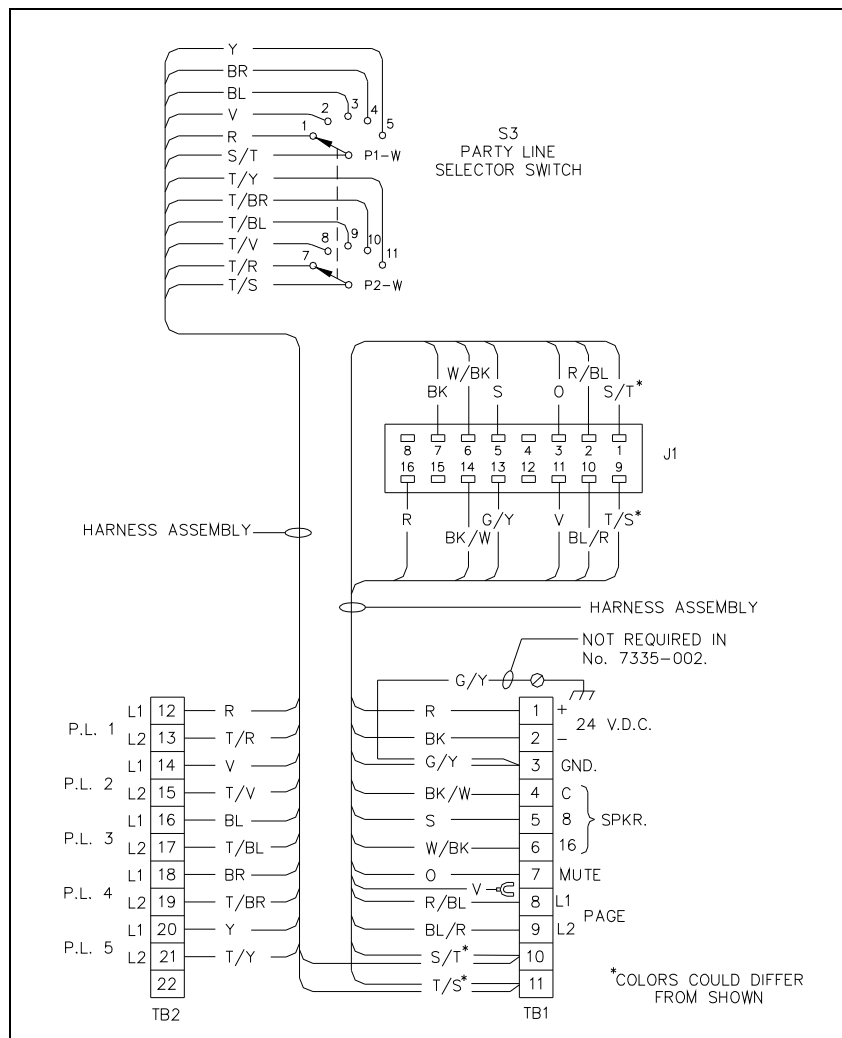



Figure 4. Wiring Diagram

## Maintenance

Regular inspection and a good preventive maintenance program will increase the reliability of your GAI-Tronics station. The GAI-Tronics Field Service Department can formulate a service contract suited to your facility's specific need for preventive maintenance.

In addition, the following procedure can be used to keep Page/Party systems operating effectively.

 **WARNING**  —Before performing any of the following preventive maintenance steps, remove all power from the station.

1. Remove the amplifier from the enclosure.
2. Visually check the interior of the enclosure for signs of contamination such as dust, condensation or process liquid.
3. Using the No. 10440-002 Maintenance Cable, plug the amplifier into the connector in the enclosure. Check, and if necessary, adjust the amplifier to maximize performance.
4. Reinstall the amplifier in the enclosure. Ensure that all gaskets and hardware are in place. Failure to install the gaskets, which also act as spacers, can result in damage to the connectors on the amplifiers and inside the enclosures and can cause system faults.

It may become necessary to re-terminate some or all of the enclosures in a system. If so, strip the wires back to clean copper and connect only one wire to each connector to allow for easier future troubleshooting.

## Troubleshooting

The following table lists some hints to aid technicians in troubleshooting.

Problem	Solution
Feedback occurs only during page.	<ol style="list-style-type: none"> <li>1. If a speaker is close to the station, try using the muting feature in the amplifier enclosure at the terminal blocks. Connect the violet wire at TB1-8 to TB1-7. Refer to the wiring diagram.</li> <li>2. Ensure that speakers attached to other stations located nearby are not pointed in your direction. If changing the orientation of the other speakers has no effect, mutual muting may be required. Mutual muting silences all the speakers within proximity to the affected stations during a page from any one of the mutually muted stations.  Connect the orange wire (spare) to the TB1-7 of all the stations to be mutually muted. <b>NOTE:</b> If too many stations are selected, paging coverage can be adversely affected.</li> <li>3. Check line terminations at the line balance assembly. Line balance assembly connections are critical.</li> </ol>
Crosstalk occurs.	One or more system cable pairs may be improperly terminated. Visually inspect the system cable connections for accidental crossing of the cable pairs or grounds.



## Replacement Parts

<b>Part No.</b>	<b>Description</b>	<b>Model 703-002</b>	<b>Model 7325-102</b>	<b>Model 7335-002</b>
10440-002	Maintenance Cable	■	■	■
46101-012	Front Panel Screw	■	■	■
12564-001	Party Line Knob and Label Kit	■	■	■
12609-002	Rotary Switch Assembly	■		
61509-009	Harness Assembly	■		
12535-001	Hardware for Harness Assembly	■		
12251-001	Spring Door Kit			■
12504-004	Door Handle			■
12505-004	Replacement Door			■
61509-010	Harness Assembly			■
12535-003	Hardware for Harness Assembly			■
61509-016	Harness Assembly		■	
25405-006	Ground Label	■	■	■
12609-001	Rotary Switch Assembly (weatherproof)		■	■
25007-004	Closure/Plug, NPT 1.25-inch		■	
12251-002	Spring Door Kit		■	
14612-003	Hub, 1.25-inch		■	
25203-002	Hub Gasket		■	

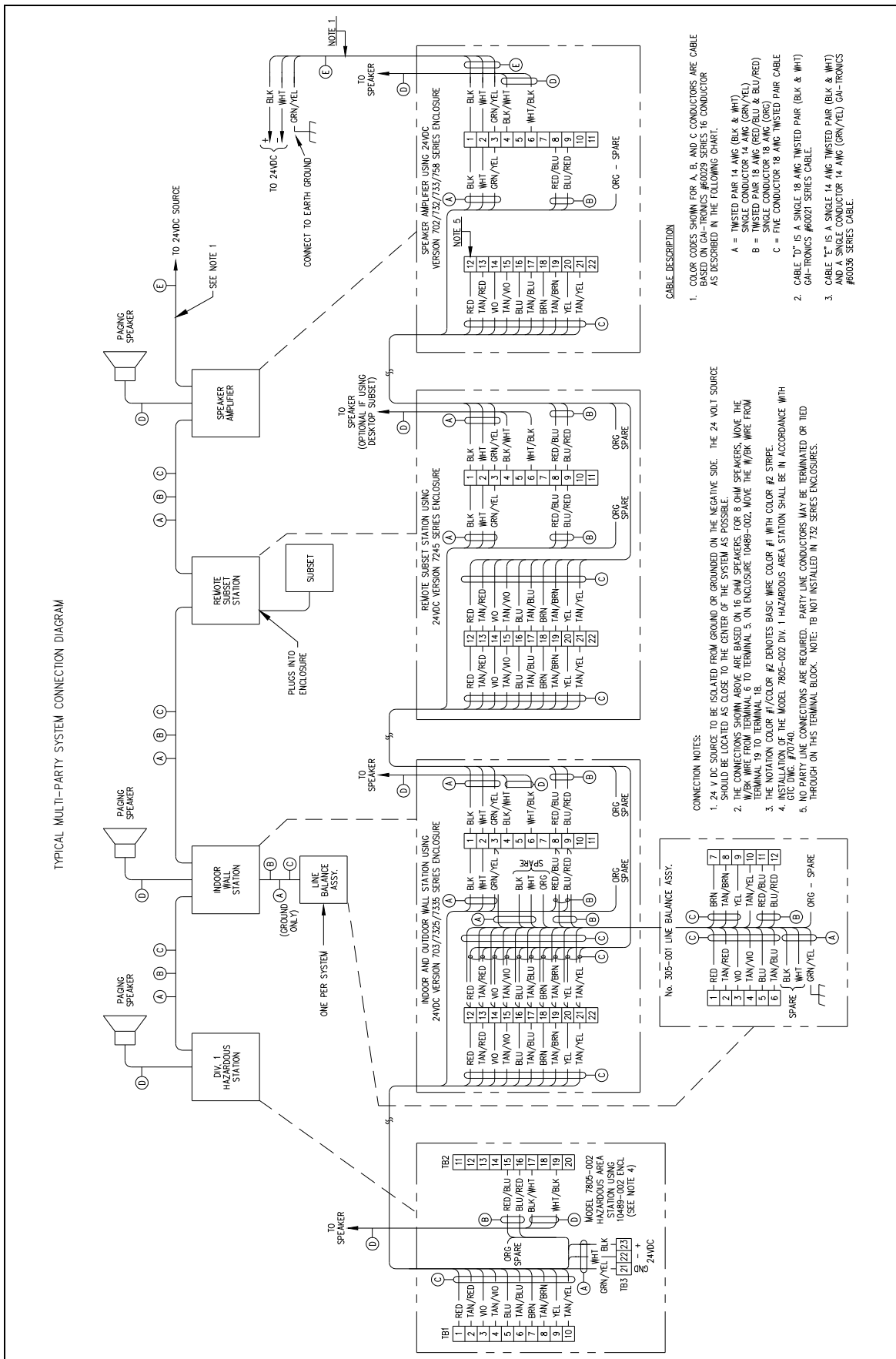

## Specifications

### Model 703-002 Indoor 24 V DC Multi-Party Amplifier Enclosure

Construction/finish.....	16-gauge cold-rolled steel; textured gray polyurethane
Mounting.....	Wall or column, four 5/16-inch mounting holes
Connections.....	Internal screw-type barrier terminal blocks
External controls .....	Rotary selector switch
Dimensions .....	12.3 H × 8.1 W × 5.1 D inches (313 × 206 × 129 mm)
Shipping weight .....	5.5 lbs. (2.5 kg)

#### Approvals

NRTL Listed for USA and Canada.....	Class 1, Div. 2, Groups A, B, C, D
Indoor environmental rating .....	Meets requirements IP21

### Model 7325-102 Aluminum 24 V DC Multi-Party Amplifier Enclosure

Construction/Finish.....	Sand-cast aluminum alloy, cam-style latch, hinged door with gasket; gray baked enamel
Mounting.....	Wall, column, or pole (mounting kit required for pole mount), four 7/16-inch mounting holes
Connections.....	Internal screw-type barrier terminal blocks
External controls .....	Rotary selector switch
Dimensions .....	14.9 H × 10.8 W × 9.6 D inches (378 × 274 × 244 mm)
Shipping weight .....	20.4 lbs. (9.3 kg)

#### Approvals

NRTL Listed for USA and Canada.....	Class I, Div. 2, Groups A, B, C, D; Class II, Div. 2, Groups F and G; Class III, Div. 2
Outdoor environmental rating.....	Type 3R

### Model 7335-002 Non-metallic Weatherproof 24 V DC Multi-Party Amplifier Enclosure

Construction/Finish.....	Glass-reinforced polyester, J-hook latch, hinged door with gasket
Mounting.....	Wall, column, or pole (mounting kit required for pole mount), four 7/16-inch mounting holes
Connections.....	Internal screw-type barrier terminal blocks
Dimensions .....	14.6 H × 10.9 W × 10.5 D inches (371 × 276 × 267 mm)
Shipping weight .....	9.6 lbs. (4.4 kg)

#### Approvals

NRTL Listed for USA and Canada.....	Class I, Div. 2, Groups A, B, C, D; Class II, Div. 2, Groups F and G; Class III, Div. 2
Outdoor environmental rating.....	Type 3R; Type 4X with door closed

# Warranty

---

Equipment. GAI-Tronics warrants for a period of one (1) year from the date of shipment, that any GAI-Tronics equipment supplied hereunder shall be free of defects in material and workmanship, shall comply with the then-current product specifications and product literature, and if applicable, shall be fit for the purpose specified in the agreed upon quotation or proposal document. If (a) Seller's goods prove to be defective in workmanship and/or material under normal and proper usage, or unfit for the purpose specified and agreed upon, and (b) Buyer's claim is made within the warranty period set forth above, Buyer may return such goods to GAI-Tronics nearest depot repair facility, freight prepaid, at which time they will be repaired or replaced, at Seller's option, without charge to Buyer. Repair or replacement shall be Buyer's sole and exclusive remedy. The warranty period on any repaired or replacement equipment shall be the greater of the ninety (90) day repair warranty or one (1) year from the date the original equipment was shipped. In no event shall GAI-Tronics warranty obligations with respect to equipment exceed 100% of the total cost of the equipment supplied hereunder. Buyer may also be entitled to the manufacturer's warranty on any third-party goods supplied by GAI-Tronics hereunder. The applicability of any such third-party warranty will be determined by GAI-Tronics.

Services. Any services GAI-Tronics provides hereunder, whether directly or through subcontractors, shall be performed in accordance with the standard of care with which such services are normally provided in the industry. If the services fail to meet the applicable industry standard, GAI-Tronics will re-perform such services at no cost to buyer to correct said deficiency to Company's satisfaction provided any and all issues are identified prior to the demobilization of the Contractor's personnel from the work site. Re-performance of services shall be Buyer's sole and exclusive remedy, and in no event shall GAI-Tronics warranty obligations with respect to services exceed 100% of the total cost of the services provided hereunder.

Warranty Periods. Every claim by Buyer alleging a defect in the goods and/or services provided hereunder shall be deemed waived unless such claim is made in writing within the applicable warranty periods as set forth above. Provided, however, that if the defect complained of is latent and not discoverable within the above warranty periods, every claim arising on account of such latent defect shall be deemed waived unless it is made in writing within a reasonable time after such latent defect is or should have been discovered by Buyer.

Limitations / Exclusions. The warranties herein shall not apply to, and GAI-Tronics shall not be responsible for, any damage to the goods or failure of the services supplied hereunder, to the extent caused by Buyer's neglect, failure to follow operational and maintenance procedures provided with the equipment, or the use of technicians not specifically authorized by GAI-Tronics to maintain or service the equipment. **THE WARRANTIES AND REMEDIES CONTAINED HEREIN ARE IN LIEU OF AND EXCLUDE ALL OTHER WARRANTIES AND REMEDIES, WHETHER EXPRESS OR IMPLIED BY OPERATION OF LAW OR OTHERWISE, INCLUDING ANY WARRANTIES OF MERCHANTABILITY OR FITNESS FOR A PARTICULAR PURPOSE.**

## Return Policy

---

If the equipment requires service, contact your Regional Service Center for a return authorization number (RA#). Equipment should be shipped prepaid to GAI-Tronics with a return authorization number and a purchase order number. If the equipment is under warranty, repairs or a replacement will be made in accordance with the warranty policy set forth above. Please include a written explanation of all defects to assist our technicians in their troubleshooting efforts.

Call 800-492-1212 (inside the USA) or 610-777-1374 (outside the USA) for help identifying the Regional Service Center closest to you.