



GAI-TRONICS® CORPORATION
A HUBBELL COMPANY

Model 1931888-3011 Page/Party® to Radio Coupler

Confidentiality Notice

This manual is provided solely as an operational, installation, and maintenance guide and contains sensitive business and technical information which is confidential and proprietary to GAI-Tronics. GAI-Tronics retains all intellectual property and other rights in or to the information contained herein, and such information may only be used in connection with the operation of your GAI-Tronics product or system. This manual may not be disclosed in any form, in whole or in part, directly or indirectly, to any third party.

General Information

The Model 1931888-3011 Coupler, when connected to a GAI-Tronics 4512 or 4514 Series 6-Channel Radio, allows a GAI-Tronics Page/Party® or Call/Talk system to communicate with other 6-Channel Radio hand-held or mobile units. Radio users traveling outside the facility at a remote location or inside a plant, can communicate with Page/Party® or Call/Talk users. Please see Figure 1 for installation layouts.

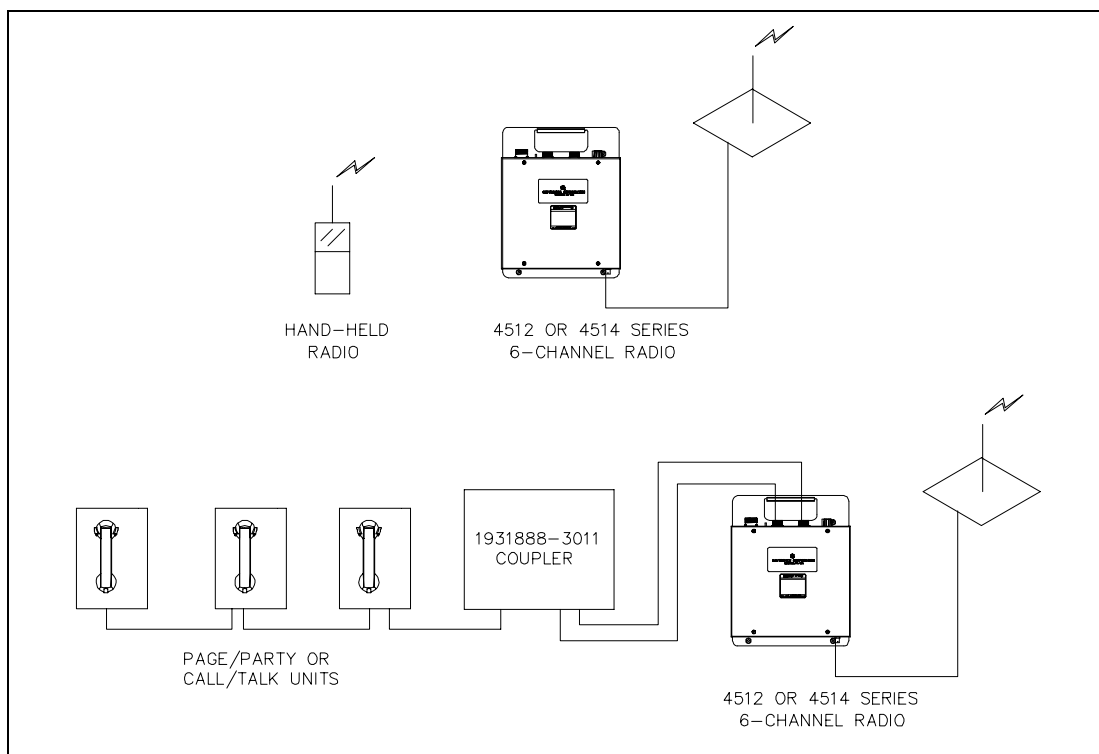

Figure 1. Installation Layout Diagram

Installation and Wiring

Punch or drill a hole in the left side or left bottom of the coupler and install a conduit fitting. This entry is for system cable from the Page/Party[®] or Call/Talk system to the coupler. Sealed threaded hubs, such as Myers Scru-Tite (1.25-inch) are recommended.

Since the Model 1931888-3011 coupler must be connected to a GAI-Tronics 6-Channel Radio, mount the coupler and radio in a place where the antenna for the radio may be appropriately positioned. Refer to the GAI-Tronics 4512 and 4514 Series 6-Channel Radio manual, Pub. 42004-387, for antenna placement information.

The coupler should be wall-mounted using the four 5/16-inch (7.938 mm) mounting holes. See Figure 2 for dimensions.

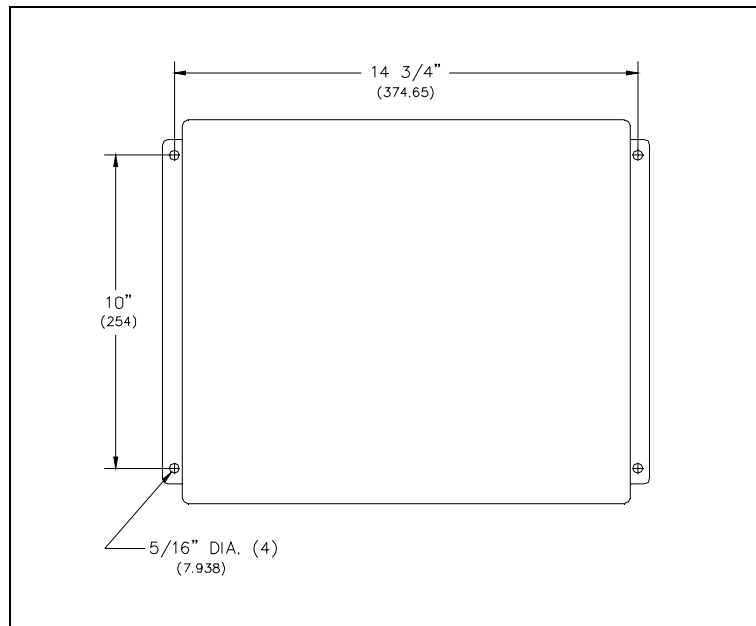

Figure 2. Mounting Details

Use GAI-Tronics 60038-101 system cable to connect the closest Page/Party[®] or Call/Talk station to the coupler:

1. Connect the 120 V ac power conductors, black, white, and green with yellow, from the Page/Party[®] or Call/Talk station to TB-1, TB-2, and TB-5 respectively in the coupler.
2. Use the red with blue and blue with red twisted pair to connect the page line L1 and L2 in the station to TB-3 and TB-4 respectively.
3. Use the red and tan with red twisted pair to connect party line 5 (or designated party line) L1 and L2 from the station to TB-7 and TB-8 respectively.
NOTE: Party line 5 is used here for explanation purposes.
4. TB-6 and TB-9 through TB-14 are factory connections.

Figure 3 and Figure 4 show the terminal blocks in the Page/Party[®] and Call/Talk stations, respectively, as well as the 14-lug terminal block in the coupler. Cables with three-prong and four-prong military style MS connectors are included with the coupler. These cables connect from the bottom of the coupler to the top of the radio.

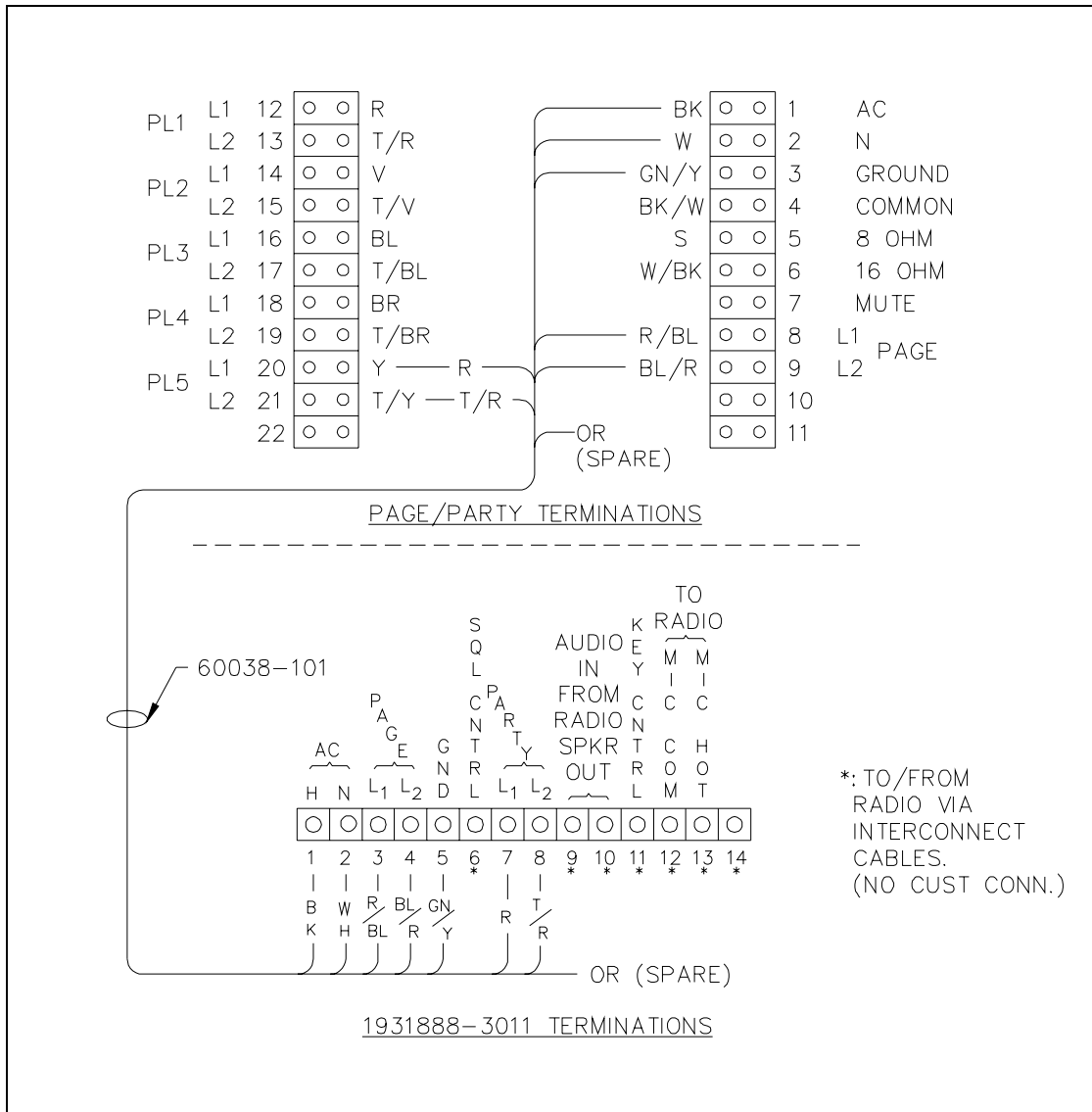

Figure 3. Wiring/Termination Details for Page/Party[®]

NOTE: Jumper P6 on the GAI-Tronics 6-Channel Radio must be installed in positions 2-3 for proper operation when used with the Model 1931888-3011 Page/Party[®] to Radio Coupler.

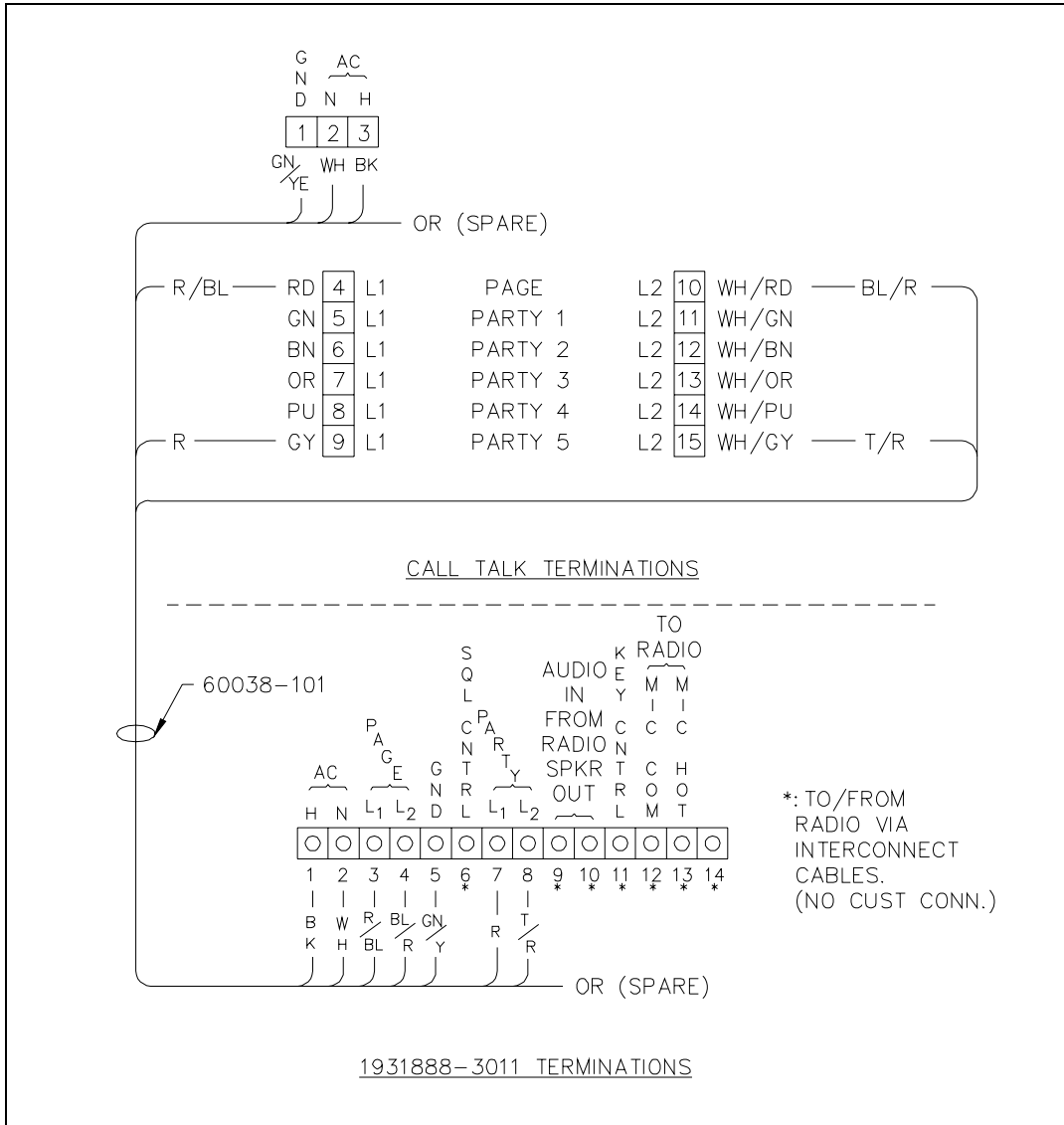

Figure 4. Wiring/Terminations for Call/Talk

Operation

The Model 1931888-3011 Coupler connects one radio frequency (channel) to one party line in the Page/Party[®] or Call/Talk system, usually party line 5. When a remote radio is not in use, the coupler monitors party line 5.

In order for a Page/Party[®] or Call/Talk user to contact a radio user, the caller must go off-hook on party line 5. The resulting communication is simplex. This means that the radio user controls the flow of the conversation with the push-to-talk, release-to-listen mechanism of the radio.

Call Originated by a Page/Party[®] or Call/Talk User to a Radio User

Audio Path from Page/Party[®] to Radio

The caller from a Page/Party[®] or Call/Talk station goes off-hook on the designated party line. This causes the station's output transformer to load the line (loop current on the line begins) at the Model 1931888-3011 coupler's TB-7 and 8 and is detected by the Model WBA2757 Sensing PCBA inside the coupler. The following relay functions occur:

1. The sensing PCBA detects the off-hook condition on the party line and activates the XFR relay and illuminates LED 3.
2. The XFR (transfer) relay is activated by the sensing PCBA. It transfers the audio path from the 'Radio-Page' line to the 'Radio-Party' line.
3. The VOX board detects audio from the system party line. When sufficient system party line audio is present, it activates VX1 relay and illuminates LED 1.
4. VX1 (VOX) relay toggle operation is activated by the Voice Operated Switch (VOX) PCBA. While the relay is activated:
 - It provides the audio connection path from the party line to the radio's microphone-in circuit (TB-12 and 13) via the coupler's RADIO VOL control (VC1).
 - It disables SQ1 (squelch) relay during party line talk mode for uninterrupted communication.
 - It provides a contact closure at TB-11 to ground to key the radio transmitter circuitry.

Audio Path from Radio to Page/Party[®]

1. After the Page/Party[®] caller has finished speaking, the radio user can simply key the microphone to answer.
2. When the coupler's radio receives the signal, the audio signal appears at the coupler's TB-9 and 10 via the 3-wire interconnect cable assembly. Squelch control is also provided from the radio to the coupler's TB-6 via the same interconnect cable.
3. With the squelch control present, the following relay functions occur:
 - SQ1 (squelch) relay is activated by SQUELCH control from the radio and illuminates LED 2. This provides the audio connection path from 'Radio-Party' line via the UA VOL control (VC2), and disables VX1 relay for uninterrupted party communications from the radio.
 - XFR (transfer) relay stays active to maintain the audio path from the radio to the Page/Party[®] system's party line.
 - VX1 (VOX) relay is disabled by SQ1 relay for uninterrupted party communications from the radio.

The signal path continues in this manner until both parties have completed their conversation.

Call Originated by Radio User to Page/Party[®] or Call/Talk System Page Line

Audio Path from Radio to Page/Party[®]

1. The radio user makes a call by simply keying the microphone and talking (push-to-talk/release-to-listen) after first ensuring that the channel is clear.
2. When the coupler's radio receives the signal, the audio signal will appear at the coupler's TB-9 and 10. Also, the SQUELCH control signal is provided from the radio at TB-6 via 3-wire interconnect cable assembly.
3. With SQUELCH control signal present, the following relay functions occur:
 - XFR (transfer) relay is inactive (no party line loop current is present [Page/Party[®] stations on-hook]) and LED 3 is off. This results in maintaining the audio path from the radio to the Page/Party[®] system's page line.
 - SQ1 (squelch) relay is activated by SQUELCH control signal from radio and illuminates LED 2. This provides the audio connection path from 'Radio-Page' line (page line TB-3 and 4) via the UA VOL control (VC2), and disables VX1 relay for uninterrupted communications from radio to the Page/Party[®] system's paging speakers.
 - VX1 (VOX) relay is disabled by SQ1 relay.

Audio Path from Page/Party[®] to Radio

The called party goes to a Page/Party[®] station, selects the dedicated party line, and goes off-hook. This causes the Page/Party[®] station's output transformer to load the line (loop current on the line begins) at the Model 1931888-3011 Coupler's TB-7 and 8 and is detected by the sensing PCBA within the coupler. For a continued explanation of the subsequent events, refer to the Call Originated by Page/Party[®] or Call/Talk User to Radio section.

Time-Out Timers

The coupler is equipped with two timer boards labeled TMR #1 and TMR #2. The function of the boards is provided to limit the transmission times of both the system and radio.

TMR #1

The TMR #1 board is controlled by the VOX board during party line communication from the Page/Party[®] system to the radio. When VOX control signal is present at TMR #1's pin 1 (system talk mode), the output at pin 2 is pulled low to activate the VX1 relay. When party line audio is no longer present on the line, the VOX output is removed and the VX1 relay drops-out to permit radio response.

However, if the station remains off-hook on the party line and noise levels occur, the VOX will detect the levels on the line, and key the radio. Under this condition, the timer board will time-out and disable the VX1 relay to remove radio keying control after approximately one minute.

TMR #2

The TMR #2 board is controlled by SQUELCH control from the radio to Page/Party[®] system's party line communications. When the SQUELCH control signal is present at TMR #2's pin 3 (radio talk mode), the output at pin 2 is pulled low to activate the SQ1 relay.

When radio SQUELCH control and audio is no longer present, the SQ1 relay drops-out to permit system response. However, if the radio remains in receive mode with SQUELCH control, party line audio cannot be transmitted back to the radio system. Under this condition, the timer board will time-out and disable the SQ1 relay to remove radio SQUELCH control after approximately one minute.

Maintenance

Control Functions

The Model 1931888-3011 Coupler contains four adjustment controls which have been pre-adjusted at the factory. Minor adjustments may be necessary for optimum system performance. Refer to Figure 5.

Control Description:

- **UA VOL:** Adjusts the audio level being coupled to the Page/Party[®] or Call/Talk system from the radio's speaker out. Clockwise rotation of the control increases the audio drive level.
- **RADIO VOL:** Adjusts the audio level being coupled to the radio's microphone-in circuitry from the Page/Party[®] or Call/Talk system. Clockwise rotation of the control increases the audio drive level.
- **VOX SENS:** Adjusts the threshold level (activation point] for the Voice Operated X switch circuitry to activate. Clockwise rotation of the control increases the sensitivity level.
- **TRANSFER SENS:** Adjusts the threshold level for the TRANSFER detection circuitry to activate. Clockwise rotation of the control increases the threshold level for XFR relay activation when an associated Page/Party[®] station is off-hook.

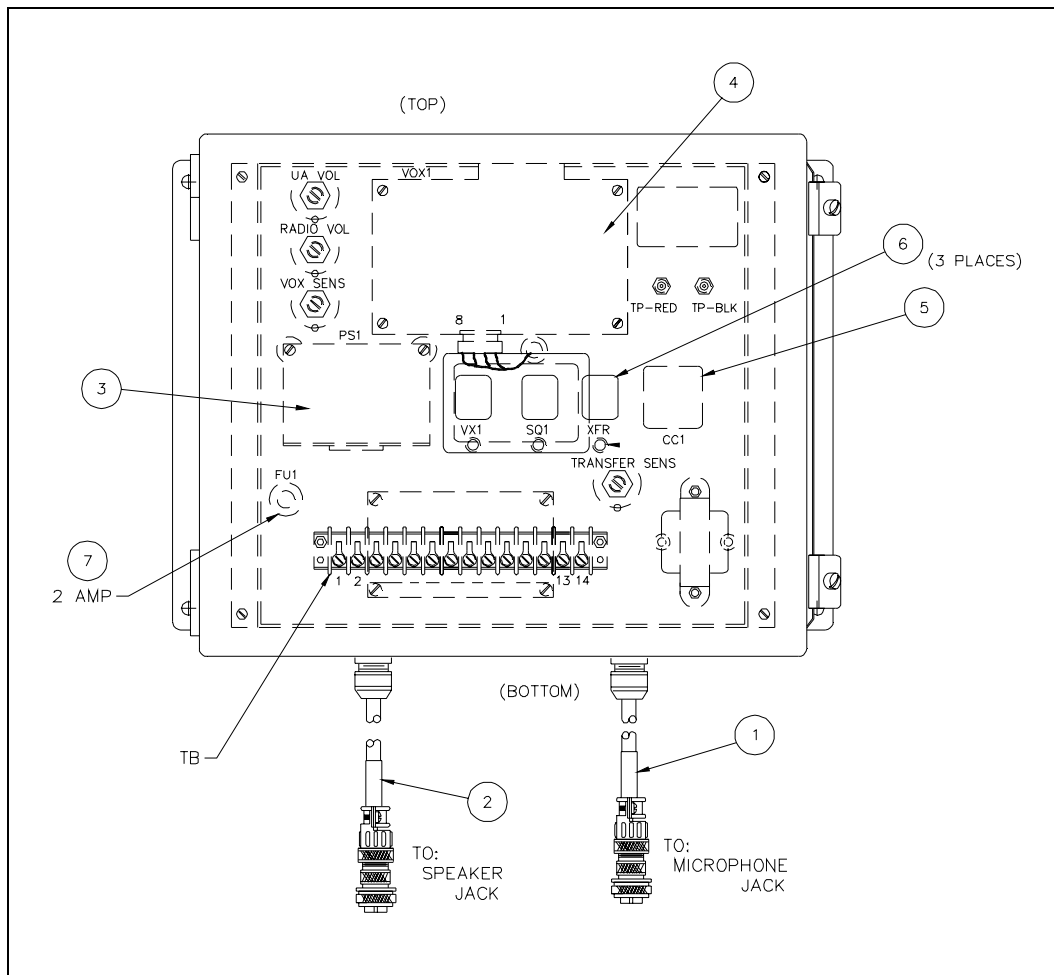

Figure 5. Part Location Diagram

Typical audio signal levels within coupler from Page/Party[®] station to coupler:

With approximately 1.5 Vrms on Page/Party[®] system party line (TB-7 and 8); with an associated Page/Party[®] station off-hook:

Audio signal at TB-12 (com) and 13; Mic In = approximately 0.45 Vrms, nominal
(Radio Vol. Min/Max range = 0 V/1.24 Vrms)

Typical audio signal levels from coupler to Page/Party[®] station:

- With approximately 10 Vrms of received speaker audio at TB-9 and 10; with XFR relay's LED 3 NOT illuminated and all associated Page/Party[®] stations on-hook:

Audio signal at TB-3 and 4 (page line) = 0.5 Vrms** nominal.
(UA Vol. Min/Max range = 0 V/3.0 Vrms**)

- With approximately 10 Vrms of received speaker audio at TB 9 and 10; with XFR relay's LED 3 illuminated and an associated Page/Party[®] station off-hook:

Audio signal at TB-7 and 8 (party line) = 0.5 Vrms** nominal.
(UA Vol. Min/Max range = 0 V/3.0 Vrms**)

**Voltages indicated are typical with indicated signal levels, actual voltages measured may vary with different audio drive levels.

Troubleshooting

Problem	Visual LED Indication	Solution
The radio operator can not make a page to the Page/Party [®] or Call/Talk system's paging speakers, but can communicate on designated party line.	XFR relay LED is illuminated.	<ol style="list-style-type: none"> 1. Check for possible off-hook Page/Party[®] stations and/or low resistance on the designated party line and correct as necessary. 2. Check adjustment of TRANSFER SENS pot. Factory setting = approx. ¼ turn CW from minimum. (Fully CCW)
Page/Party [®] system user has low modulation audio to radio operator.	N/A	<ol style="list-style-type: none"> 1. Check adjustment of RADIO VOL. pot. Re-adjust as necessary. Factory setting = approximately mid range. 2. Check for proper jumper location of J2 inside the associated radio unit. (For coupler operation, J2 must be in Pos. 2 and 3 versus Pos.1 and 2 [factory setting])
While the Page/Party [®] station is off-hook, the associated coupler's XFR relay activates, but VX1 relay does NOT activate when speaking into handset.	XFR relay LED is illuminated and VX1 relay LED is NOT illuminated.	<ol style="list-style-type: none"> 1. Check adjustment of VOX SENS pot. (Factory setting = approx. ¼ turn CW from minimum. [Fully CCW]) 2. Check for defective VOX PCB assembly. Replace WBA4417, if necessary.
No communications in either direction.	No relay LEDs are lit in any mode.	<ol style="list-style-type: none"> 1. Check for proper ac supply voltage to coupler at TB-1 and 2. 2. Check FU1. Replace, if necessary, with fuse of the same value and rating. 3. Check CO1B power supply. Replace, if necessary. 4. Check external wiring connections.
No communication from radio operator to Page/Party [®] station is possible, but communications from Page/Party [®] station to radio operator are OK.	If SQ1 relay LED is NOT illuminated:	<ol style="list-style-type: none"> 1. Check CC1 module. Replace WBA4259, if necessary. 2. Check speaker cable assembly (3-wire connector) connections.
	If SQ1 relay LED IS illuminated:	<ol style="list-style-type: none"> 1. Replace SQ1 relay. 2. Check external page connections to Page/Party[®] system.
Carrier detect does not activate on 6-Channel Radio. Does not function.	N/A	Jumper P6 on 6-Channel Radio must be installed in positions 2-3 for proper operation.

Specifications

Construction/finish:..... 16-gauge steel, oil resistant gasket, ANSI #61 gray polyester coating, NEMA-12 rated

Mounting..... Four 5/16-inch (7.9mm) mounting holes, center to center measurements of 14.75 × 10 inches L × H (374.65 × 254 mm)

Dimensions..... 14 × 12 × 6 inches L × W × D (354.0 × 304.8 × 152.4 mm)

Shipping weight..... 28 lb. (12.72 kg)

Power requirements:

Voltage..... 108–132 V ac (50/60 Hz), 120 V ac, nominal

Power Consumed..... 24 VA, 9 watts

Replacement Parts

Refer to Figure 5 for locations.

Item #	Part Number	Description
1	43276A-7011	Cable Assembly, Microphone
2	43276A-7012	Cable Assembly, Speaker
3	C01B	PCBA, Power Supply
4	WBA4417	PCBA, VOX Board Assembly
5	WBA4259	Module, Squelch Control (CC1)
6	45004-005	Relay
7	51812-001	Fuse 2 amp, 125 V

Warranty

Equipment. GAI-Tronics warrants for a period of one (1) year from the date of shipment, that any GAI-Tronics equipment supplied hereunder shall be free of defects in material and workmanship, shall comply with the then-current product specifications and product literature, and if applicable, shall be fit for the purpose specified in the agreed-upon quotation or proposal document. If (a) Seller's goods prove to be defective in workmanship and/or material under normal and proper usage, or unfit for the purpose specified and agreed upon, and (b) Buyer's claim is made within the warranty period set forth above, Buyer may return such goods to GAI-Tronics' nearest depot repair facility, freight prepaid, at which time they will be repaired or replaced, at Seller's option, without charge to Buyer. Repair or replacement shall be Buyer's sole and exclusive remedy. The warranty period on any repaired or replacement equipment shall be the greater of the ninety (90) day repair warranty or one (1) year from the date the original equipment was shipped. In no event shall GAI-Tronics warranty obligations with respect to equipment exceed 100% of the total cost of the equipment supplied hereunder. Buyer may also be entitled to the manufacturer's warranty on any third-party goods supplied by GAI-Tronics hereunder. The applicability of any such third-party warranty will be determined by GAI-Tronics.

Services. Any services GAI-Tronics provides hereunder, whether directly or through subcontractors, shall be performed in accordance with the standard of care with which such services are normally provided in the industry. If the services fail to meet the applicable industry standard, GAI-Tronics will re-perform such services at no cost to buyer to correct said deficiency to Company's satisfaction provided any and all issues are identified prior to the demobilization of the Contractor's personnel from the work site. Re-performance of services shall be Buyer's sole and exclusive remedy, and in no event shall GAI-Tronics warranty obligations with respect to services exceed 100% of the total cost of the services provided hereunder.

Warranty Periods. Every claim by Buyer alleging a defect in the goods and/or services provided hereunder shall be deemed waived unless such claim is made in writing within the applicable warranty periods as set forth above. Provided, however, that if the defect complained of is latent and not discoverable within the above warranty periods, every claim arising on account of such latent defect shall be deemed waived unless it is made in writing within a reasonable time after such latent defect is or should have been discovered by Buyer.

Limitations / Exclusions. The warranties herein shall not apply to, and GAI-Tronics shall not be responsible for, any damage to the goods or failure of the services supplied hereunder, to the extent caused by Buyer's neglect, failure to follow operational and maintenance procedures provided with the equipment, or the use of technicians not specifically authorized by GAI-Tronics to maintain or service the equipment. **THE WARRANTIES AND REMEDIES CONTAINED HEREIN ARE IN LIEU OF AND EXCLUDE ALL OTHER WARRANTIES AND REMEDIES, WHETHER EXPRESS OR IMPLIED BY OPERATION OF LAW OR OTHERWISE, INCLUDING ANY WARRANTIES OF MERCHANTABILITY OR FITNESS FOR A PARTICULAR PURPOSE.**

Return Policy

If the equipment requires service, contact your Regional Service Center for a return authorization number (RA#). Equipment should be shipped prepaid to GAI-Tronics with a return authorization number and a purchase order number. If the equipment is under warranty, repairs or a replacement will be made in accordance with the warranty policy set forth above. Please include a written explanation of all defects to assist our technicians in their troubleshooting efforts.

Call 800-492-1212 (inside the USA) or 610-777-1374 (outside the USA) for help identifying the Regional Service Center closest to you.