



GAI-TRONICS®
A HUBBELL COMPANY

Rugged Analog Auto-Dial Telephones

TABLE OF CONTENTS

<i>Confidentiality Notice</i>	<i>1</i>
<i>General Information</i>	<i>1</i>
<i>Operation</i>	<i>1</i>
<i>Installation</i>	<i>2</i>
Safety Guidelines	2
Security Hardware	2
Conduit Installation Details	2
Model 227-001	4
Model 247-001	6
Model 257-001	8
Model 277-001	10
Flush-Mount Installation.....	10
Surface-Mount Installation using a 236-00x Series or Model 238-001 Enclosure	11
Models 277-002BH and 277-002BHAC	12
Flush-Mount Installation.....	12
Surface-Mount Installation using the No. 238-003 Enclosure.....	13
Programming Auto-Dial Numbers	14
Ringdown Operation	14
<i>Maintenance</i>	<i>15</i>
Service	15
Preventive Maintenance for Models 277-001/-002BH/-002BHAC	15
Cleaning	15
Prevention	15
Volume Control Jumper Setting	16
Auxiliary Output	16
<i>Replacement Parts and Accessories</i>	<i>17</i>
<i>Specifications</i>	<i>18</i>
Electrical (Typical)	18
Environmental	18
Mechanical	19
<i>Approvals</i>	<i>20</i>



GAI-TRONICS®
A HUBBELL COMPANY

Rugged Analog Auto-Dial Telephones

Confidentiality Notice

This manual is provided solely as an installation, operation, and maintenance guide and contains sensitive business and technical information that is confidential and proprietary to GAI-Tronics. GAI-Tronics retains all intellectual property and other rights in or to the information contained herein, and such information may only be used in connection with the operation of your GAI-Tronics product or system. This manual may not be disclosed in any form, in whole or in part, directly or indirectly, to any third party.

General Information

GAI-Tronics Rugged Auto-Dial Telephones are ideally suited for conditions that are too harsh for a standard telephone. When the handset is removed from the cradle, a preprogrammed number of up to 31 digits is automatically dialed. The telephones are fully line-powered and do not require internal batteries.

This manual applies to the following telephones:



- Model 227-001 Public Access Auto-dial Telephone
- Model 247-001 Indoor Industrial Auto-dial Telephone
- Model 257-001 Weatherproof Industrial Auto-dial Telephone
- Model 277-001 Flush-Mount Auto-dial Telephone
- Models 277-002BH and 277-002BHAC Flush-Mount Behavioral Health Telephone

Operation

To auto-dial the stored telephone number:

1. Lift the handset. After approximately 1 second, the preprogrammed number is dialed automatically.
2. The handset receiver volume is adjustable using the handset pressbar or the volume control pushbutton located on the front of the telephone. The volume increases with each button press in six steps. Pressing the volume control a seventh time will reset the volume to the original level. When the handset is returned to its cradle, the receiver volume is returned to the initial volume setting. This behavior can be changed by the volume control jumper setting (see the Volume Control Jumper Setting section).
3. To redial, place the handset on hook and wait approximately 3 seconds. Lift the handset and the preprogrammed number is redialed.
4. Place the handset back on-hook after completion of the call.

Installation

 **ATTENTION**  —Installation should be performed by qualified personnel and only in accordance with the National Electrical Code or applicable local codes.

Safety Guidelines

When installing any GAI-Tronics telephone equipment, please adhere to the following guidelines to ensure the safety of all personnel:

- NEVER install telephone wiring during a lightning storm.
- **Install a UL Listed lightning arrester** on any telephone installed where the telephone or telephone cable is at risk of being exposed to lightning strikes. The lightning arrester must be installed as close as possible to maximize the protection. It must not be installed within the enclosure supplied with the telephone. Please consult our Service Center at 800-492-1212 for further information.
- Do not install telephone jacks in wet locations unless the jack is specifically designed for wet locations.
- Do not touch uninsulated telephone wires or terminals unless the telephone line has been disconnected at the network interface.

Security Hardware

Models 227-001, 277-001, 277-002BH, and 277-002BHAC are vandal resistant. The front panel of each of these models is attached to its enclosure with security screws. A GAI-Tronics Model 233-001 Security Screwdriver or Torx T-25 security head tip (sold separately) is necessary to install the security screws. Model 247-001 and 257-001 Telephones' front panels are attached with standard Phillips head screws.

Conduit Installation Details (Applicable to Models 247-001 and 257-001)

GAI-Tronics recommends installing telephone lines in conduit to protect against accidental damage and vandalism. The following measures help prevent moisture from entering the enclosure (see [Figure 1](#) and [Figure 2](#)):

- Conduit should enter the enclosure from the bottom whenever possible.
- Sealed fittings should be installed at all cable entry points.
- Silicone sealant or equivalent should be applied around and inside all conduit entries to prevent moisture ingress.

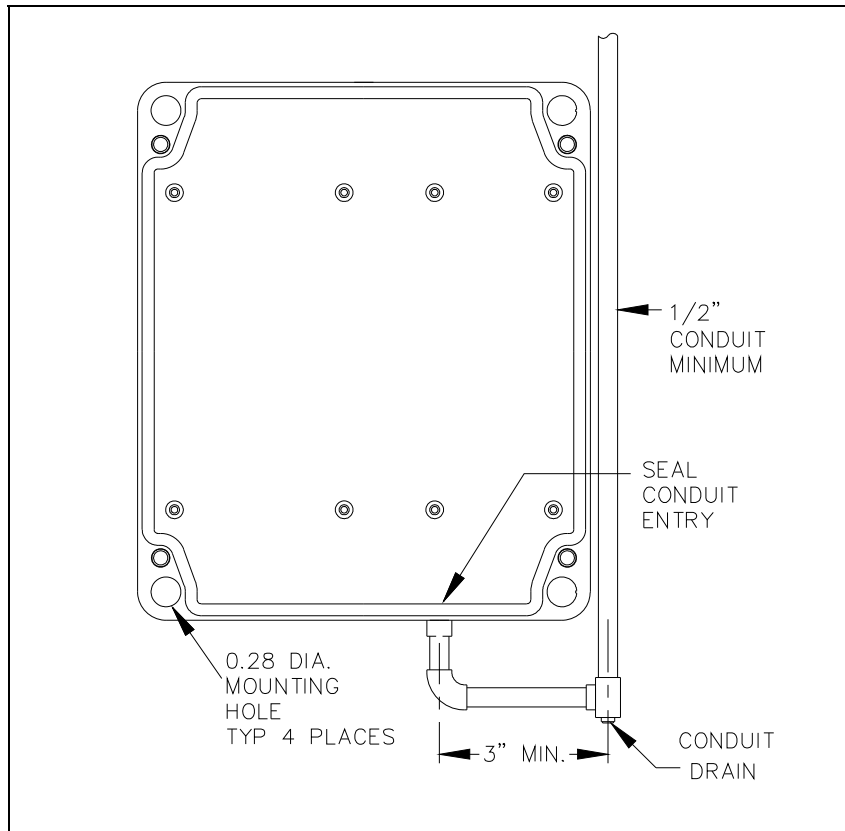

Figure 1. Bottom entry conduit installation details (RECOMMENDED for non-metallic enclosures)

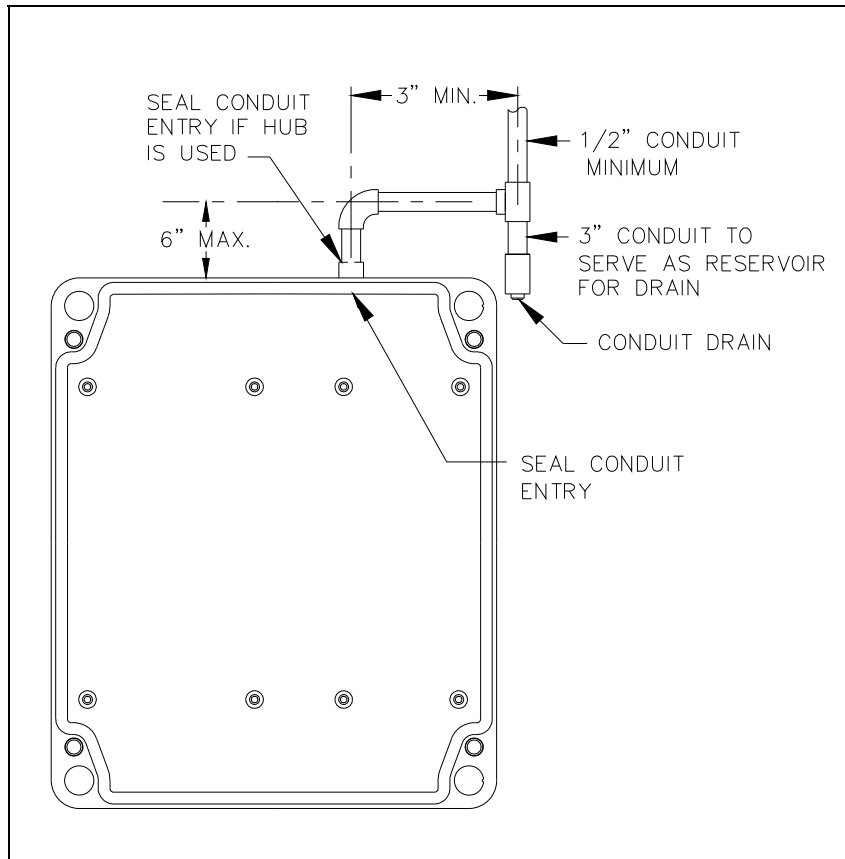

Figure 2. Top entry conduit installation details (NOT RECOMMENDED)

Model 227-001

The mounting and wiring instructions for the Model 227-001 Public Auto-Dial Telephone are as follows:

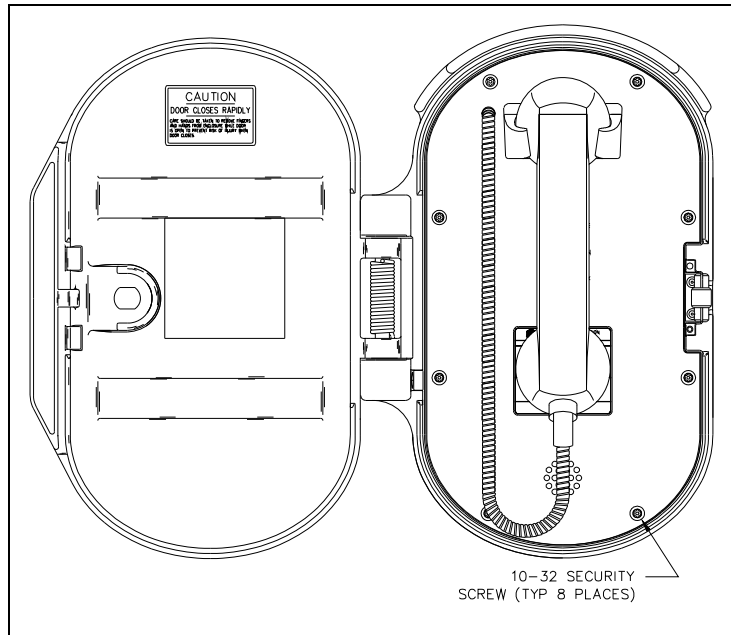

Figure 3. Model 227-001 Public Access Telephone with spring loaded door in the open position

1. Remove the eight security screws from the front panel. Remove the front panel and set aside.

NOTE: There is a 7-foot half-modular telephone cord attached to the PCBA in the rear.

2. Determine which hole pattern to use for mounting (see [Figure 5](#)).

- There are eight mounting holes in the back of the enclosure in two 4-hole patterns.
- Use the 7.875 × 4.00-inch hole pattern for mounting to a wall (outside pattern).
- Use the 5.25 × 4.00-inch hole pattern when using the Model 232-001 Pole Mounting Kit (inside pattern).

3. Insert the four (provided) hole plugs in the unused holes.

4. Position the enclosure on the mounting surface and secure it with four fasteners.

- The holes in the telephone enclosure accept 3/8-inch screws or bolts.
- The Model 232-001 Pole Mounting Kit includes four 3/8-16 × 1-inch shoulder bolts with Teflon seal washers.

NOTE: Use only the round head, hexagon head, or pan head screws that are provided. **Do not** use screws designed to be countersunk for mounting the enclosure.

5. Install a conduit fitting in one of the ½-inch NPT conduit entrances provided at both the top and bottom of the unit and insert the conduit into the fitting (see [Figure 4](#)).

The bottom entry is preferred.

6. Plug the unused access hole using the provided 3/8-inch Allen drive plug.

NOTE: Use silicone sealant or equivalent around and inside all conduit entries.

7. *Outdoor Installations:* install a (customer-supplied) telephone line suppressor on the telephone line.

8. Pull the telephone line through the conduit and into the enclosure.

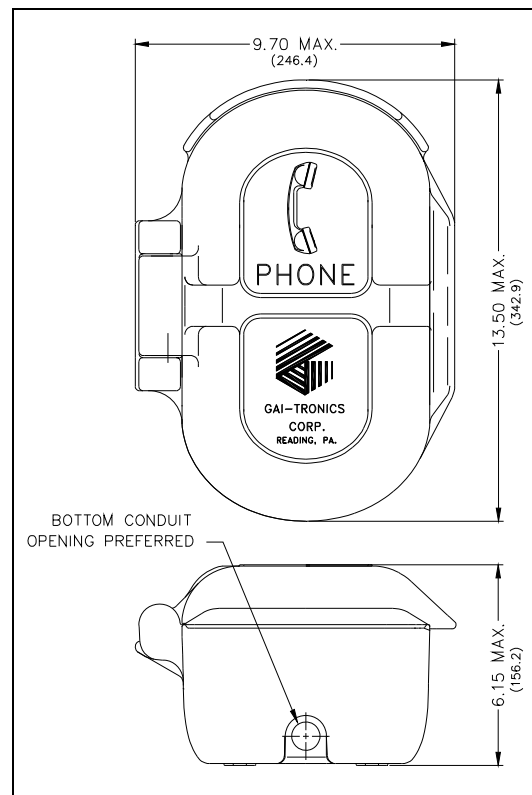

Figure 4. Model 227-001 Outline

9. Connect the telephone's modular cord to the incoming subscriber line with the appropriate connector.
10. Verify operation by calling to and from another telephone.
11. Replace the front panel assembly and tighten the eight front panel screws.

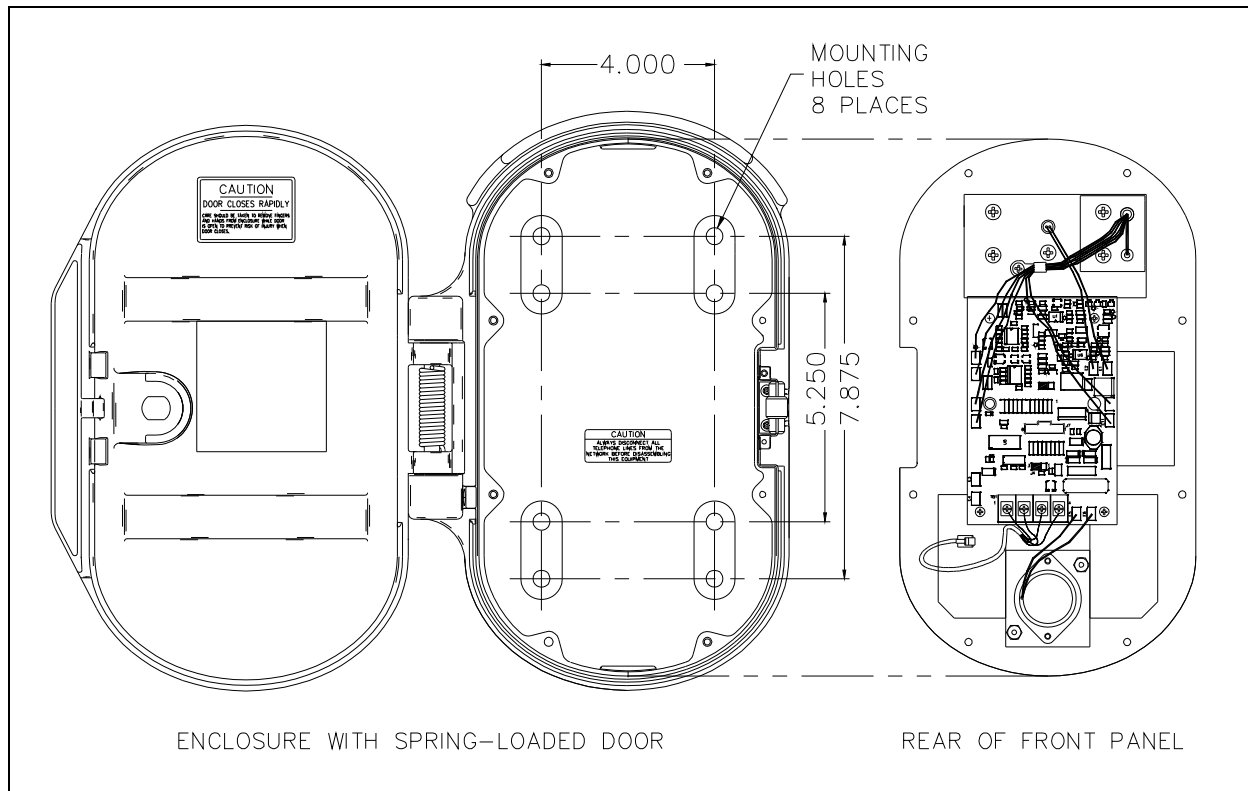

Figure 5. Model 227-001 Outline and Mounting Drawing

Model 247-001

1. Remove the four front panel screws using a standard Phillips screwdriver.
2. Remove the front panel assembly and set it aside.
3. Disconnect the 7-foot half-modular telephone cord from the PCBA terminal strip, if connected (see [Figure 7](#)).
4. *Conduit Installations:* See the [Conduit Installation Details](#) section.

If using the gland bushing provided with the unit: Drill a 0.688-inch diameter hole at either drill spot on the bottom of the rear enclosure.

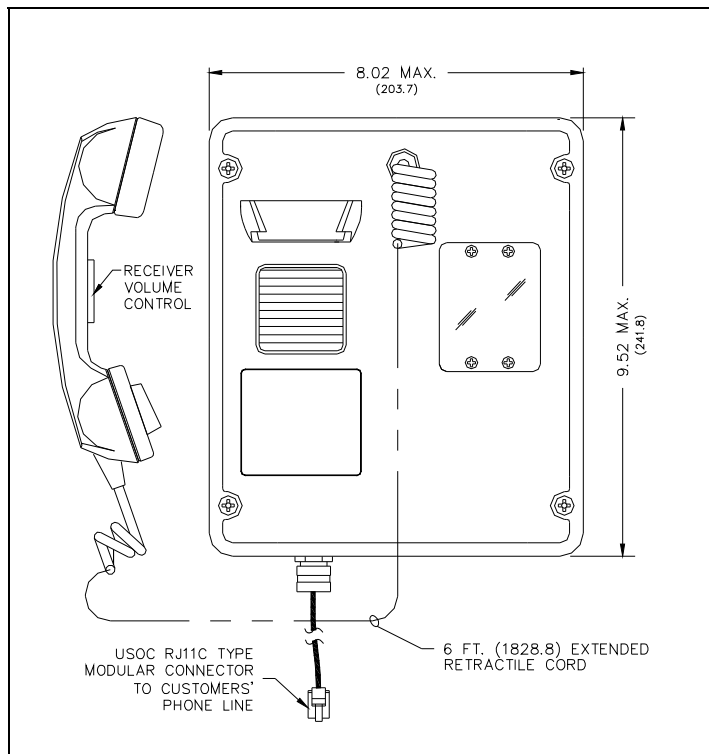

Figure 6. Model 247-001 Outline Drawing

5. Push the free end of the telephone cord through the gland bushing using needle-nose pliers. Allow 8–10 inches of telephone cord to extend past the bushing.
6. Tighten the bushing around the cord.
7. Feed the free end of the telephone cord through the hole in the enclosure.
8. Secure the bushing in the hole with the supplied locknut using a 7/8-inch wrench and channel lock pliers.
9. Mount the enclosure to the wall with four 1/4-20 machine screws with nuts and washers or with four #14 wood screws of the appropriate length for the mounting surface (see [Figure 8](#)).
10. Connect the telephone cord to the PCBA terminal strip (see [Figure 7](#)).

11. Replace the front panel assembly and secure it with the four front panel screws.
12. Connect the telephone cord's modular connector to the incoming subscriber line using the appropriate mating connector.
13. Check for proper telephone operation by calling to and from another telephone.

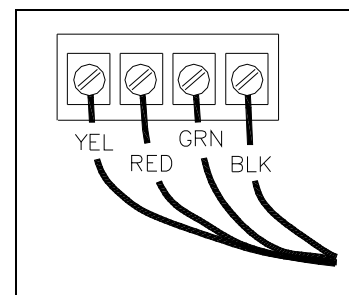

Figure 7. PCBA Connection

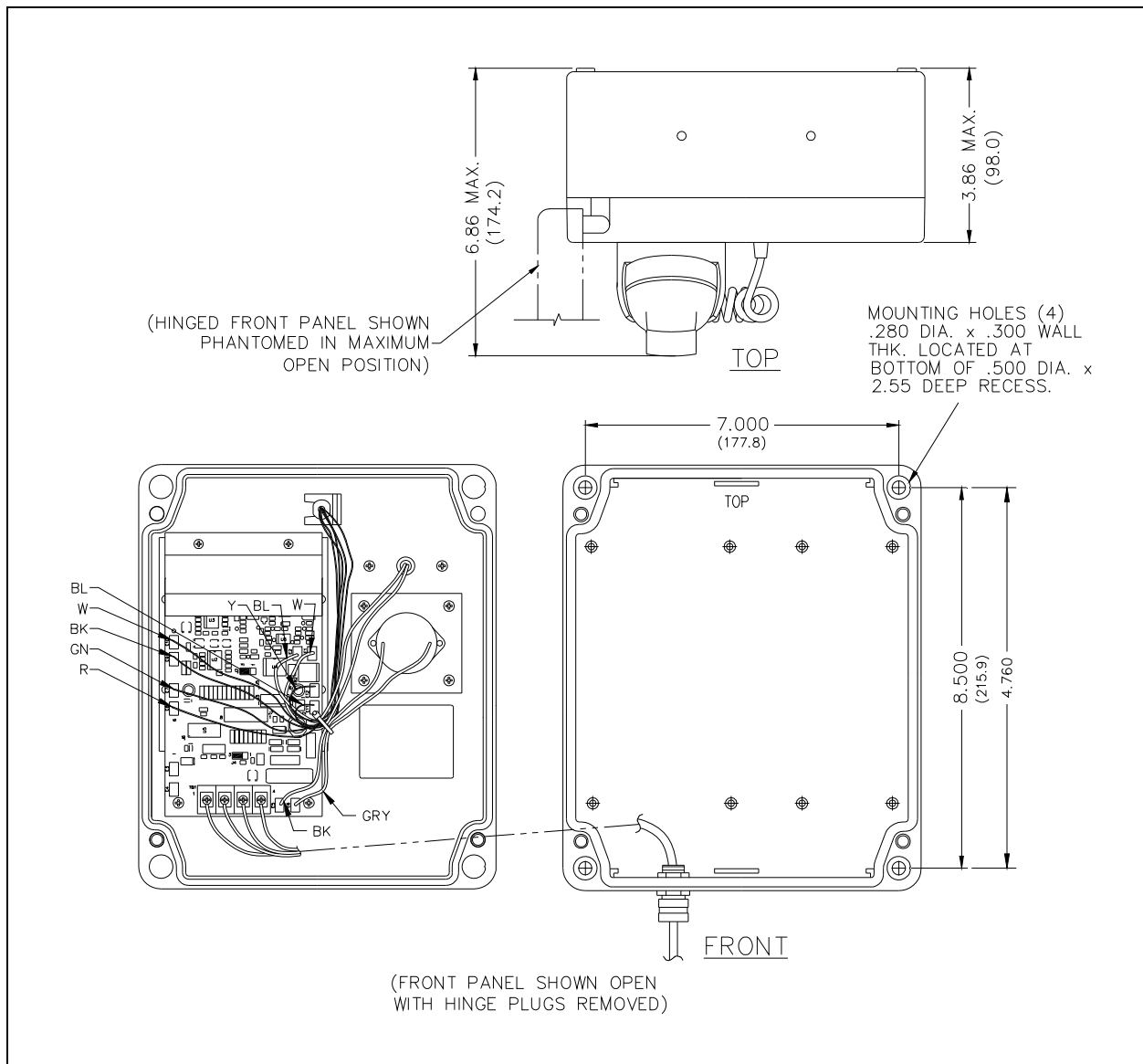

Figure 8. Model 247-001 Mounting Diagram

Model 257-001

1. Open the front door and remove the four outermost screws from the mid-section using a standard Phillips screwdriver.
2. Pull the enclosure apart until encountering a slight resistance on the left side.
3. Open the front half of the enclosure to the left until the length of the telephone cord inside the enclosure can be disconnected from the PCBA terminal strip, if connected (see Figure 10).
4. Pull on the left side of the enclosure until the hinge plugs pull loose to separate the front and rear halves.

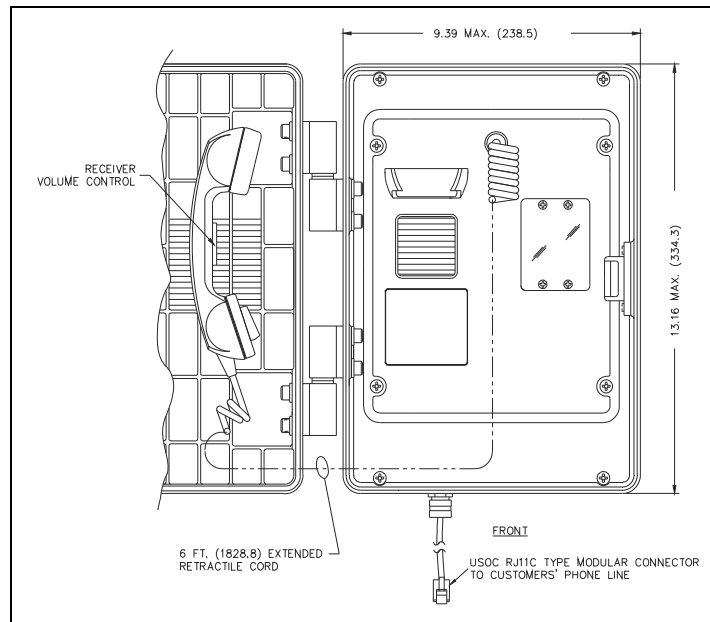

Figure 9. Model 257-001 Outline Drawing

5. Set the front half of the enclosure aside.
6. *Conduit Installations:* See the Conduit Installation Details section.

If using the gland bushing provided with the unit: Drill a 0.688-inch diameter hole at either drill spot on the bottom of the rear enclosure.

7. Push the free end of the telephone cord through the gland bushing using needle-nose pliers. Allow 8–10 inches of telephone cord to extend past the bushing.
8. Tighten the bushing around the cord.
9. Feed the free end of the telephone cord through the hole in the enclosure.
10. Secure the bushing in the hole with the supplied locknut using a 7/8-inch wrench and channel locks to tighten.
11. Mount the enclosure on the wall using four ¼-20 machine screws with nuts and washers or with four #14 wood screws of the appropriate length for the mounting surface (see Figure 10).
12. *Outdoor Installations:* Install a (customer-supplied) telephone line suppressor on the telephone line.
13. Connect the telephone cord to the PCBA terminal strip (see Figure 7).
14. Close the front half of the enclosure and secure it by replacing the four outermost screws.
15. Connect the telephone's modular cord to the incoming subscriber line with the appropriate mating connector.
16. Verify operation by calling to and from another telephone.

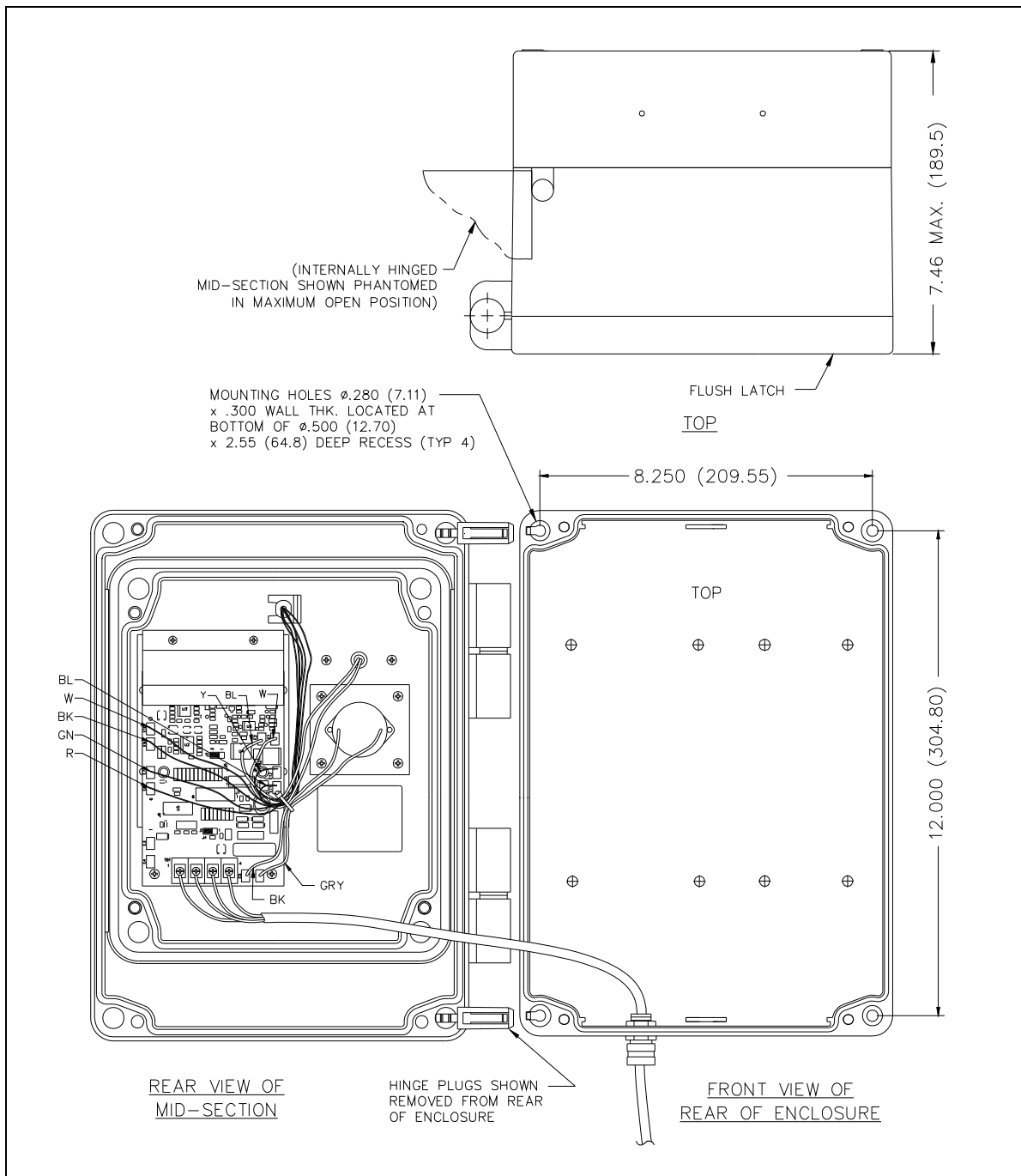

Figure 10. Model 257-001 Mounting Detail

Model 277-001

Flush-Mount Installation

Use the supplied back box to mount the Model 277-001 Telephone in a Model 234 Series Communication Station or for flush-mount installations

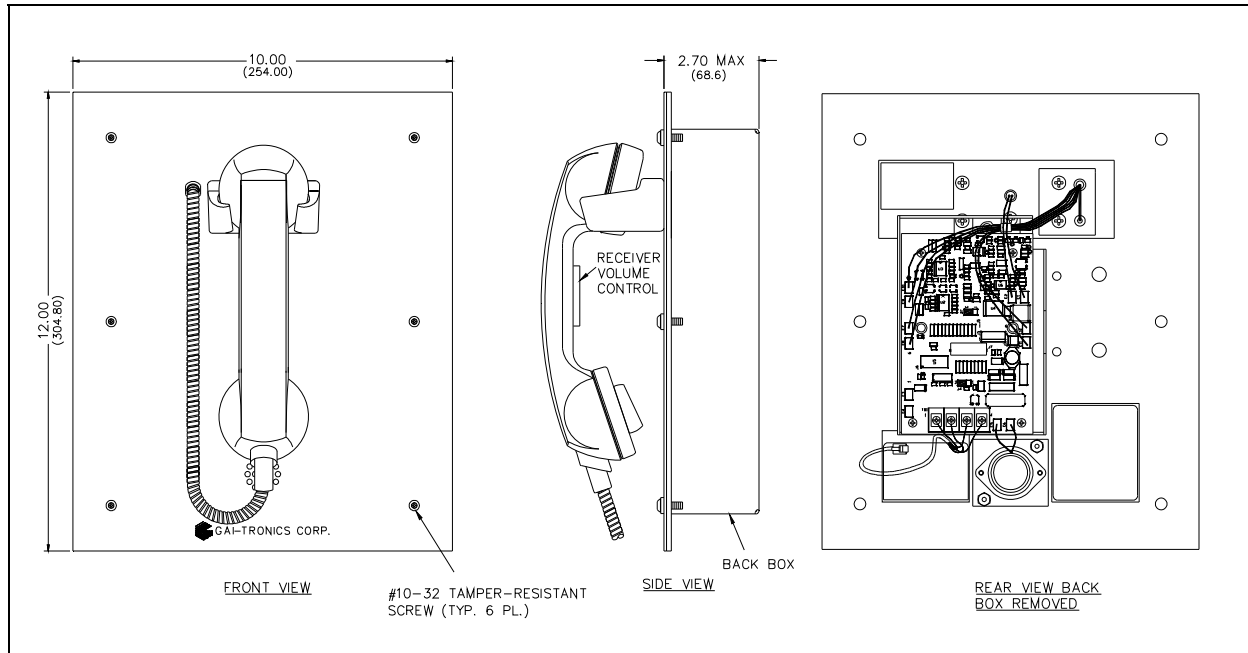

Figure 11. Model 277-001 Outline Drawing

1. Mount the back box to the structure using appropriate hardware (see [Figure 12](#)).
2. *Outdoor installations:* Install a (customer-supplied) telephone line surge suppressor on the telephone line.
3. Remove a tapered plug from a cable-entry hole in the back box and install the (customer-supplied) telephone line and cable fitting.
4. *Recommendation*—use silicone sealant or equivalent around and inside all conduit entries.
5. Connect the modular connector of the 7-foot supplied telephone cord to the incoming subscriber line or the telephone line suppressor (if applicable) using the appropriate mating connector.
6. Attach telephone's front panel to the mounting flanges of the back box using the six supplied #10 security screws and the six black flat washers.

A Model 233-001 Security Screwdriver (sold separately) is required to install the security screws.

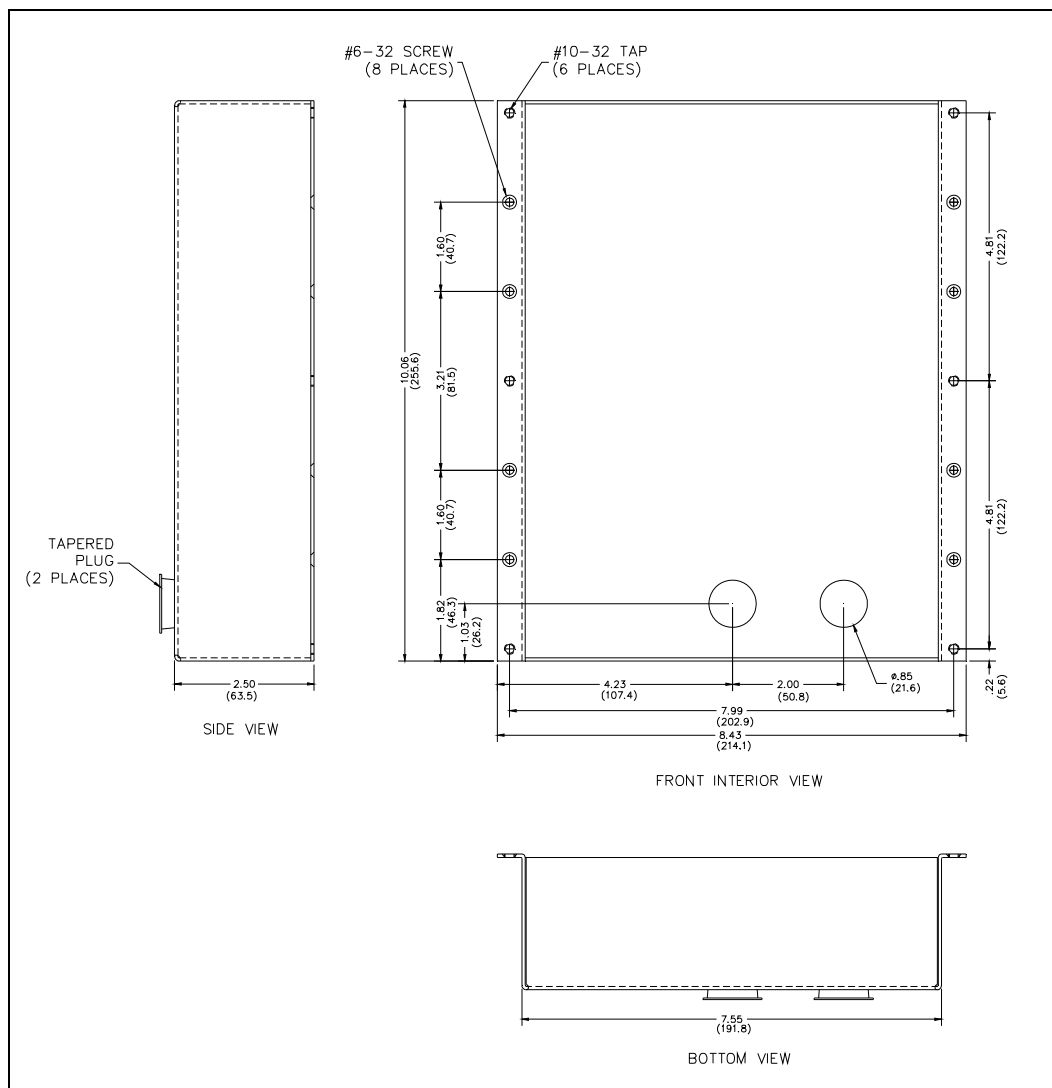

Figure 12. Model 277-001 Back Box Mounting Detail

Surface-Mount Installation using a 236-00x Series or Model 238-001 Enclosure

NOTE: The back box included with the Model 277-001 Telephone is not required for use with a Model 236 Series or Model 238-001 Surface-Mount Enclosure and must be removed.

1. Drill or punch conduit entries. (The Model 238-001 already includes a rear-access hole with gasket.)

⚠ WARNING ⚠ —To prevent accidentally damaging equipment, drill all holes before mounting the telephone.

2. *Outdoor Installations:* Install a (customer-supplied) telephone line suppressor on the telephone line.
3. Connect the telephone's modular plug to the incoming subscriber line or the telephone line suppressor (if applicable) using the appropriate mating connector.
4. Attach the telephone's front panel to the mounting flanges of the Model 236 Series or 238-001 Surface-Mount Enclosure using the six supplied #10-32 security screws and six black flat washers. A Model 233-001 Security Screwdriver (sold separately) is required to install the security screws.
5. Torque the cover screws to 10–12 in·lb.

Models 277-002BH and 277-002BHAC

Flush-Mount Installation

NOTE: See the cutout and support framing details for installation planning (see [Figure 15](#)).

1. Remove the four nuts from the back of the dust cover and remove it from the front panel (see [Figure 13](#) and [Figure 14](#)).

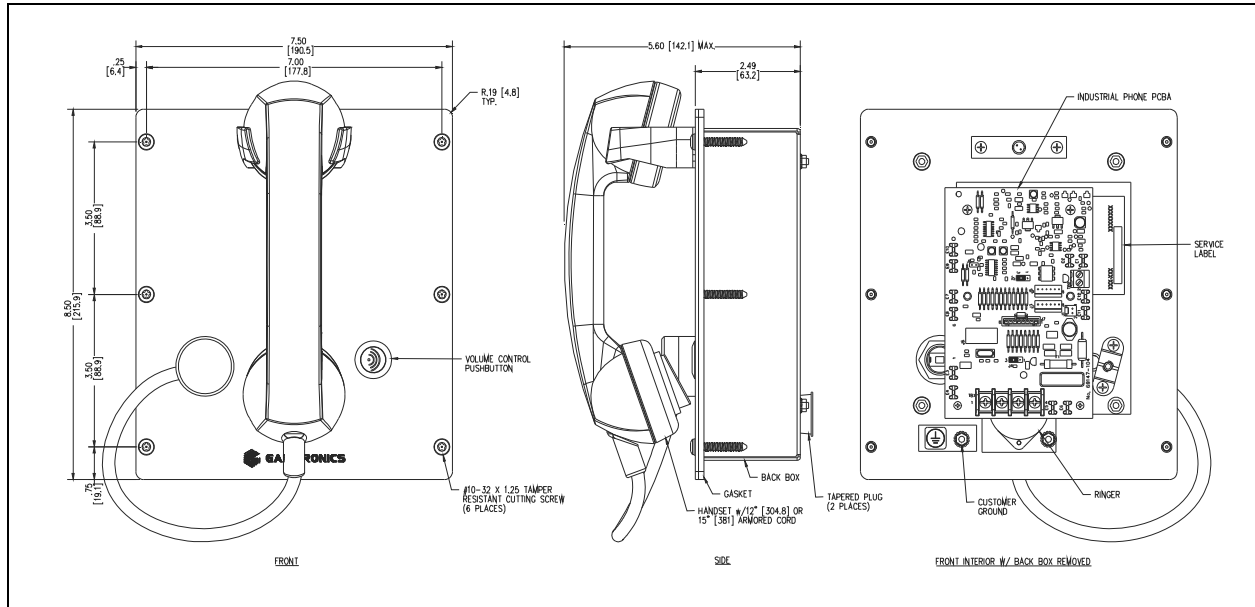

Figure 13. Models 277-002BH/-002BHAC Outline Drawing

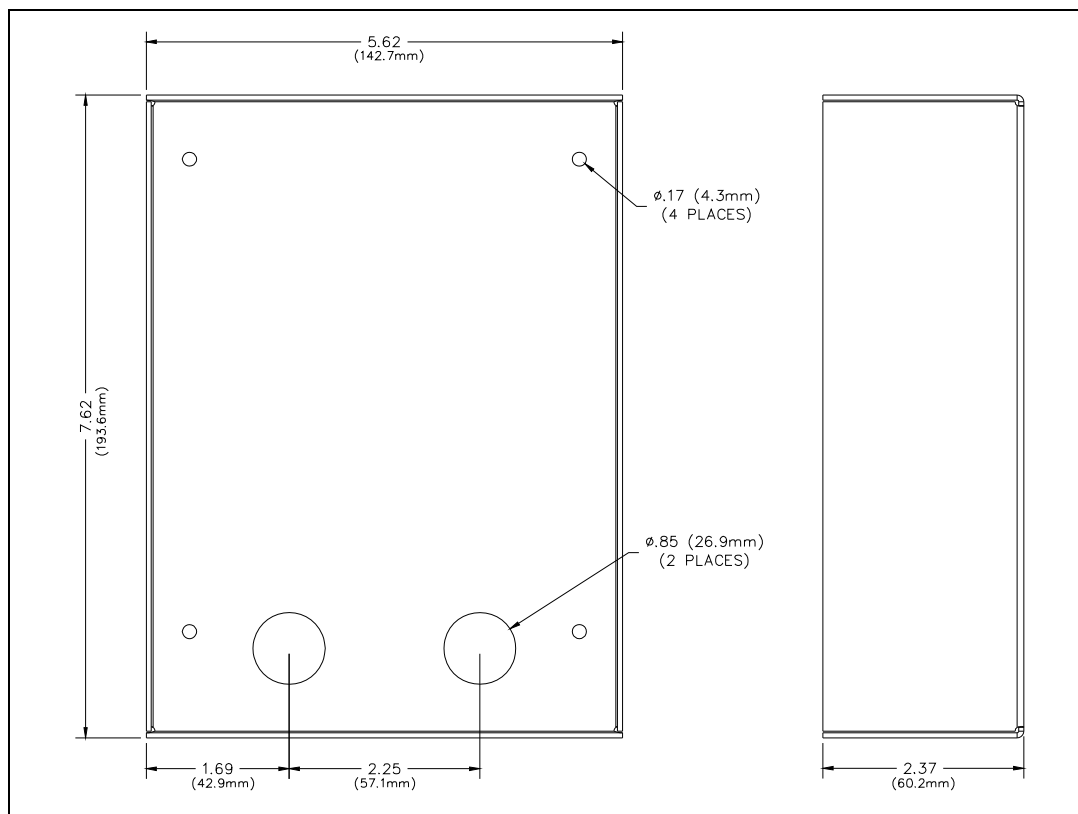

Figure 14. Models 277-002BH/-002BHAC Dust Cover Detail

2. Feed the telephone line through either of the cable entry holes in the dust cover (see [Figure 14](#)).
3. Connect the telephone's modular cord to the incoming subscriber line with the appropriate connector.
NOTE: Telephone line connections directly to TB1 are acceptable.
4. Verify operation by calling to and from another telephone.
5. Place the dust cover back onto the telephone and secure it using the four nuts removed in step one.
6. Attach the front panel assembly to the mounting surface using the six supplied #10-32 thread-cutting security screws (see [Figure 15](#)).

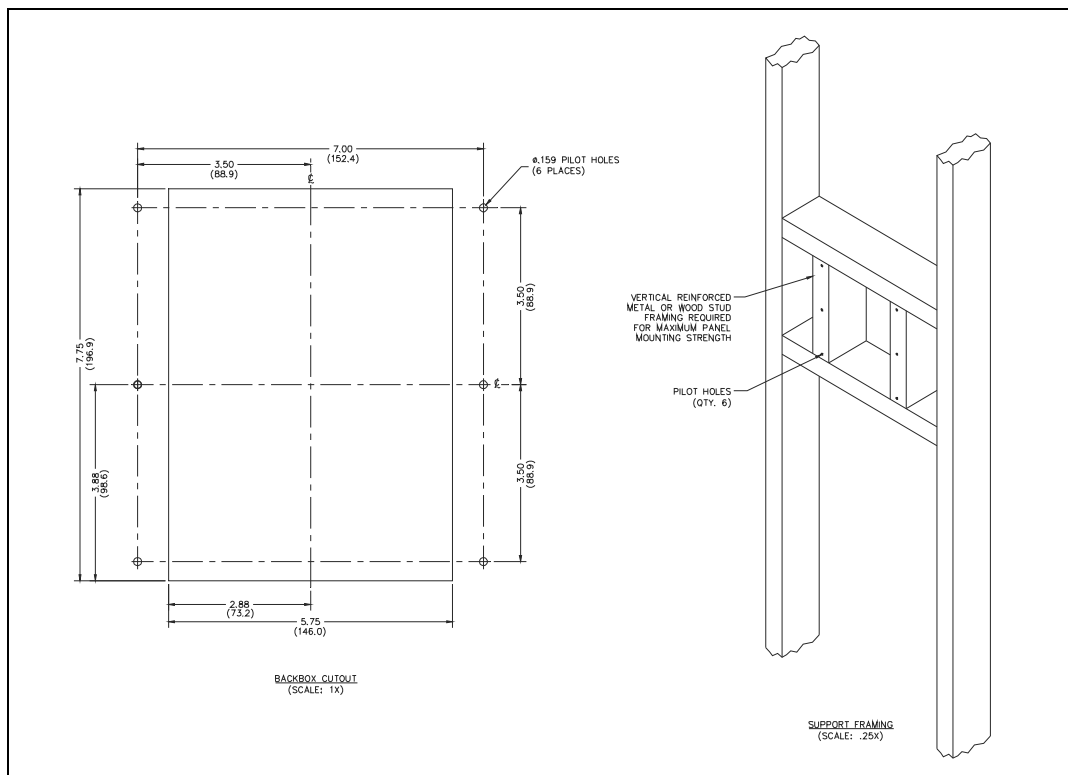

Figure 15. Cutout Detail and Framing Support for Models 277-002BH/-002BHAC

Surface-Mount Installation using the No. 238-003 Enclosure

The Model 238-003 Enclosure includes rear and bottom access holes for cable entry. Use the rear access hole(s) for a completely hidden installation or the bottom access hole(s) for conduit installation.

NOTE: The dust cover included with the Model 277-002BH and 277-002BHAC Telephones is not required for use with the Model 238-003 Surface-Mount Enclosure and must be removed.

1. Connect the telephone's modular plug to the incoming subscriber line using the appropriate mating connector.
2. Attach the telephone's front panel to the mounting flanges of the No. 238-003 Surface-Mount Enclosure using the six #10-32 security machine screws supplied with the surface mount enclosure kit and the six black flat washers included with the telephone

NOTE: Do not use the thread-cutting screws supplied with the telephone in the No 238-003 enclosure's tapped holes. A Model 233-001 Security Screwdriver (sold separately) is required for installing the security screws.

3. Torque the screws to 10–12 in·lb.

Programming Auto-Dial Numbers

1. Remove the front panel assembly by following the appropriate instructions provided in this manual for your phone.
2. Insert the supplied portable keypad and cable into J7 (see Figure 16).
3. The plug-in jumper on the connector header J2 should be installed between pins 2 and 3 (default).
4. Connect the telephone line cable from the telephone to an active telephone line.
5. Remove the handset from the cradle (off hook) and enter the desired telephone number into memory using the keypad mounted on the back of the front panel assembly.
6. Once the number is entered, replace the handset in the cradle (on hook) and move the plug-in jumper on J2 to pins one and two.
7. Test the auto-dial number by removing the handset from its cradle (off hook)—the telephone should automatically dial the preprogrammed number.
8. Once the auto-dial number is verified, remove the keypad and cable and store in a safe location.
9. Reattach the front panel to the enclosure.

NOTE: The programmed number remains in memory until it is reprogrammed. Disconnecting the telephone line does not erase the programmed number. The number is stored in nonvolatile electronic memory. Standby batteries are not required.

Ringdown Operation

The plug-in jumper on the connector header J2 is factory installed between pins two and three. This setting allows loop detection and dial tone when the handset is removed from its cradle. No programming changes are necessary for ringdown operation.

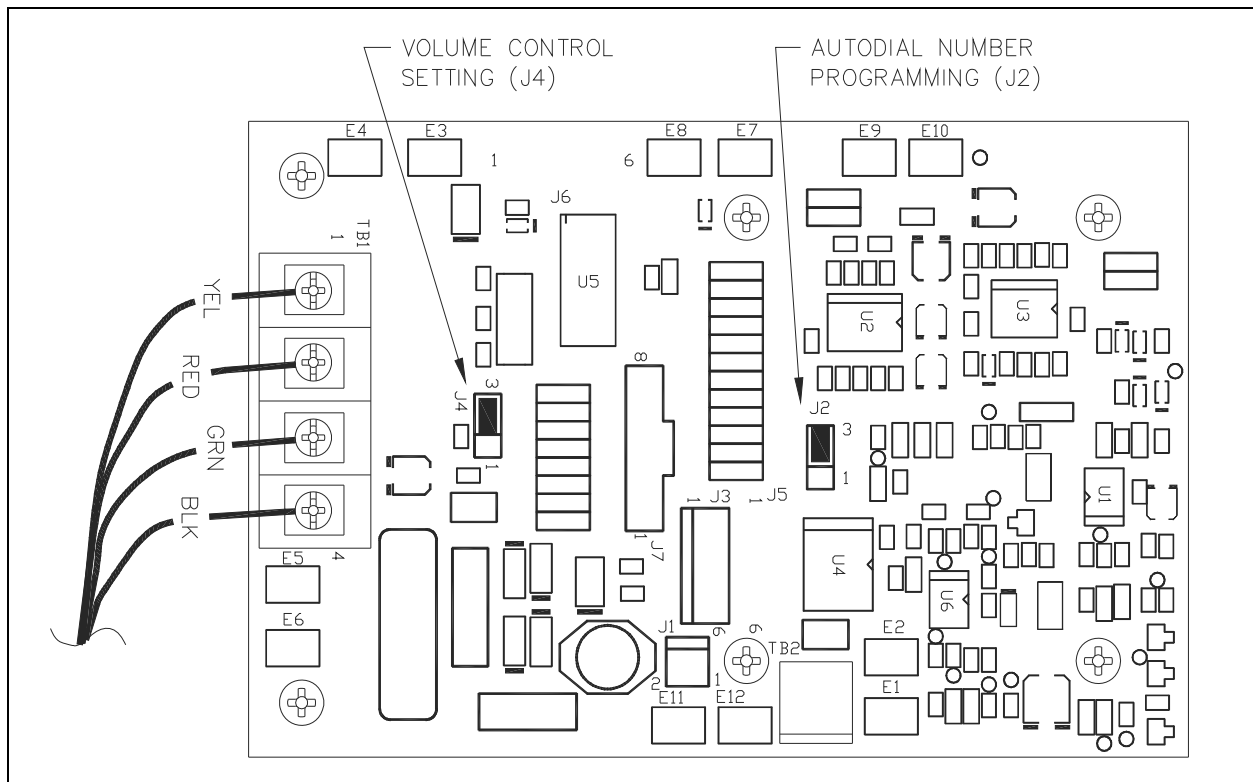

Figure 16. Main PCBA Jumper Locations for Auto-dial Telephone

Maintenance

Service

Contact a GAI-Tronics regional service center for an RA# (return authorization number) if the telephone requires service. Equipment must be shipped prepaid to GAI-Tronics with a return authorization number and a purchase order number. Repairs will be made without charge if the equipment is under warranty. Please include a written explanation of all defects to assist our technicians in their troubleshooting efforts.

Call 800-492-1212 inside the USA or 610-777-1374 outside the USA for identification of the nearest regional service center.

Preventive Maintenance for Models 277-001/-002BH/-002BHAC

Stainless steel does require maintenance to prevent corrosion from occurring. Different installation locations may require more regular maintenance than others, depending on the environment and exposure to airborne contaminants. The following maintenance steps should be performed on a regular basis or when corrosion is first noticed on the Model 277-001 telephone.

Cleaning

- For general cleaning, wipe the surface with a cleanser or a cleanser and water mixture. Any cleanser that is safe for glass is usually safe for stainless steel. Wipe dry.
- If corrosion or rusting is noticed, remove with a non-abrasive commercial cleanser and water. Rub stained areas in the same direction as the existing grain. Stubborn stains may be removed with a magnesium oxide, ammonia, and water paste. Wipe clean with water rinse and dry.

Prevention

Automotive wax provides the best results in preventing corrosion on stainless steel. Simply apply wax, let dry to a haze, and buff to a shine with a clean dry cloth. This application should protect the telephone surface for many months as it will allow natural reformation of the chromium oxide layer.

Do NOT use steel wool, sandpaper, mineral acids, bleaches, or chlorine cleansers on the stainless surface.

Volume Control Jumper Setting

The handset receiver volume control is factory set to default to its original setting (0 dB) when the telephone is hung up. Move jumper **J4** from positions 2 and 3 to positions 1 and 2 to save the current volume control setting when hanging up the telephone (see [Figure 17](#)).

Auxiliary Output

Each telephone includes one isolated solid-state volt-free closure capable of switching a maximum of 48 V dc, 125 mA; or 28 V ac R_{MS} , 80 mA R_{MS} . **TB2 (AUX OUT)** on the main PCBA provides the connections for the auxiliary output (see [Figure 17](#)).

The auxiliary output allows peripheral equipment, such as beacons, video cameras, and alarm generators, to be activated when the handset is off hook. The relay remains energized for the duration of the call.

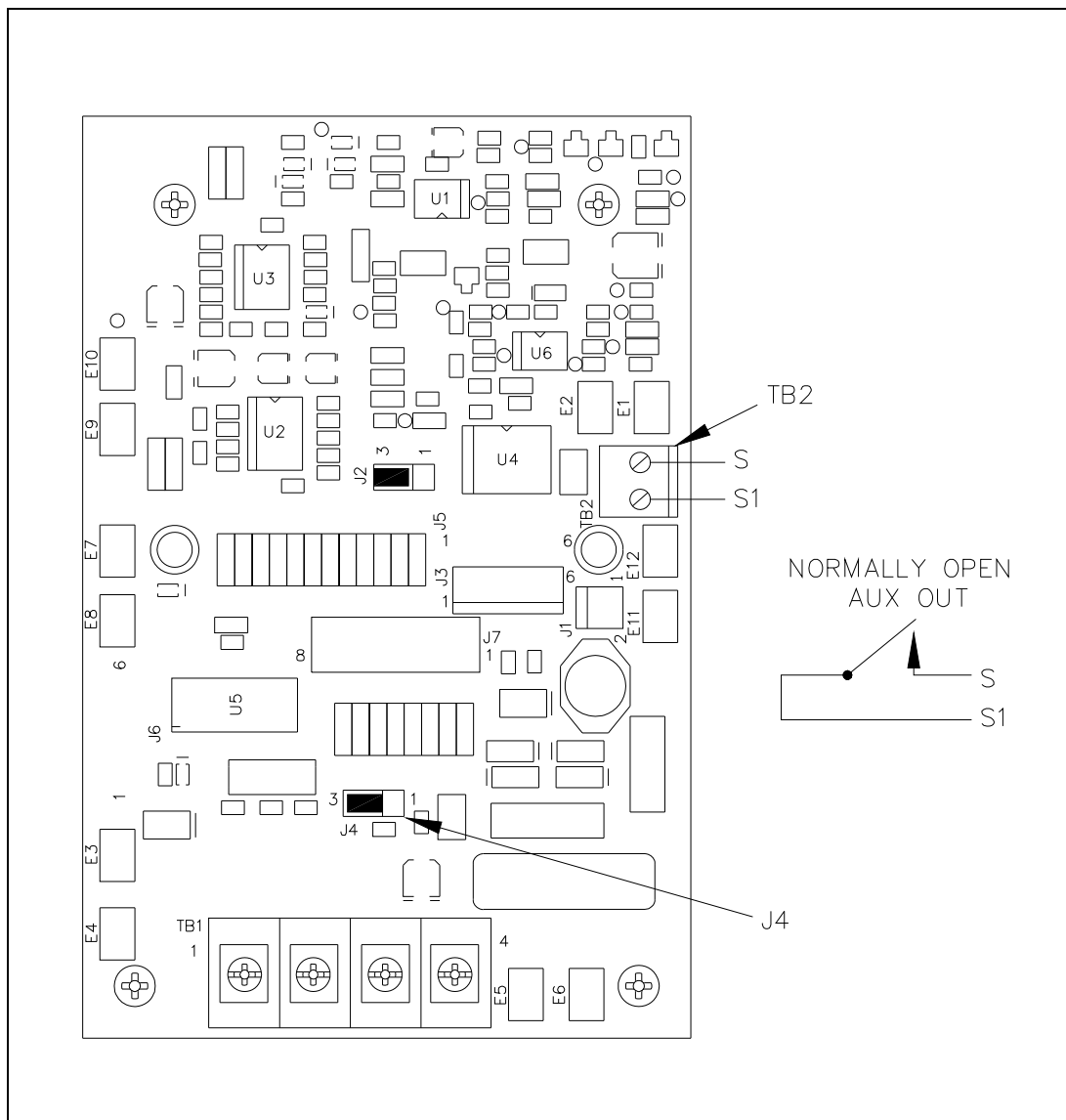

Figure 17. Location of TB2 on Main PCBA

Replacement Parts and Accessories

Table 1. Replacement Parts

Part No.	Description	227-001	247-001	257-001	277-001	277-002BH	277-002BHAC
10111-104	Handset Assembly with 6-foot Hytrel [®] Coiled Cord, Volume Control, and Noise-Canceling Mic, Black		■	■			
10117-001	Handset Assembly with 15-inch Armored Cord, Volume Control, and Noise-Canceling Mic, Black	■					
10117-003	Handset Assembly with 29-inch Armored Cord, Volume Control, and Noise-Cancelling Mic, Black				■		
10113-030	Handset Assembly with 12-inch armored cord					■	
10113-020	Handset Assembly with 15-inch armored cord						■
12512-001	Hookswitch/Cradle Kit		■	■		■	■
12512-002	Hookswitch/Cradle Kit	■			■		
12516-001	Replacement Mounting Screw Kit (Phillips, #10-32 machine screw, 10 pack)		■	■			
12542-002	Replacement Mounting Screw Kit (Security, #10-32 machine screw, 15 pack)	■			■		
12542-003	Replacement Mounting Screw Kit (Security, #10 thread cutting screw, 15 pack)					■	■
13707-004	Replacement Ringer Assembly	■	■	■	■	■	■
12513-006	Replacement Door Kit			■			
69147-104	Replacement PCB Assembly	■	■	■	■	■	■

Table 2. Available Accessories

Part No.	Accessories	227-001	247-001	257-001	277-001	277-002BH	277-002BHAC
12565-009	Ring Relay Kit				■		
12565-010	Ring Relay Kit		■	■			
12573-001	Spring Door Kit			■			
12576-117	Front Panel Replacement Kit	■					
230-001	Pole Mounting Kit, Rugged Phone/RF Callbox			■			
231-001FS	Pole Mounting Kit for BH/FS Series Telephones when installed in a No. 238-003 Enclosure					■	■
231-002	Pole Mounting Kit for Model 247-001 and for Model 277-001 when installed in a No. 238-001 Enclosure		■		■		
232-001	Pole Mounting Kit (22x Series)	■					
233-001	Security Screwdriver, Torx T-25 Tip	■			■	■	■
238-001	Surface-Mount Enclosure, Stainless Steel, Standard				■		
238-003	Surface-Mount Enclosure, Stainless Steel, BH Telephones					■	■

Specifications

Electrical (Typical)

Auto-dialer maximum 31 digits, with internal 12-button pad, field-programmable
 Frequency response..... 300 to 3,000 Hz
 Inter-digit pause 100 ms
 Minimum loop current 20 mA
 Signaling tone (DTMF)..... 100 ms tone duration
 Supervisory dc current minimum 20 mA dc; maximum 60 mA dc
 Supervisory dc voltage..... 24 V dc to 60 V dc (not polarity sensitive)
 Network interface..... loop start
 Network signaling DTMF
 Auxiliary output (isolated solid-state switch) 48 V dc @ 125 mA
 28 V ac_{RMS} @ 80 mA_{RMS}
 Handset receiver volume gain..... +18 dB in 3 dB increments

Environmental

Operating temperature -40 °F to +140 °F (-40 °C to +60 °C)
 Humidity 90% non-condensing

Mechanical**Model 227-001**

Construction

Enclosure	thick-walled cast aluminum with protective gray coating
Panel	0.125-inch brushed aluminum
Finish	gray polyurethane enamel
Handset/cord	G-style with armored cord and volume switch
Front panel	0.125-inch brushed anodized aluminum
Hookswitch	chrome-plated zinc, stationary switching mechanism

Models 247-001 and 257-001

Enclosure	high-impact, glass-reinforced polyester
Handset cord	G-style handset/Hytrel® 6-foot extended length (standard) and volume switch
Connections.....	6.5-foot (1.98 m) modular line cord

Dimensions, Outside

Model 247-001	9.5 H × 8.0 W × 6.9 D in (242 × 204 × 174 mm)
Model 257-001	13.2 H × 9.4 W × 7.4 D in (344 × 239 × 188 mm)
Mounting.....	four 0.280-inch diameter holes

Weight

Model 247-001	6.0 lb (2.70 kg)
Model 257-001	8.2 lb (3.72 kg)

Model 277-001

Enclosure construction: Front panel	14-gauge (0.075 inch) type 304 brushed stainless steel
Enclosure construction: Back box.....	16-gauge (0.060 inch) cold-rolled steel with black polyester finish

Dimensions

Front panel.....	12.00 H × 10.00 W in (305 × 254 mm)
Back box (overall)	10.06 H × 8.43 W × 2.50 D in (256 × 214 × 63.5 mm)
Cutout for mounting back box.....	10.13 H × 7.63 W in (257 × 194 mm)

Weight.....	6.5 lb (3.0 kg)
-------------	-----------------

Handset/cord	G-style with armored cord and volume switch
Hookswitch	chrome plated zinc; stationary switching mechanism

Models 277-002BH/002BHAC

Enclosure Construction

Front panel.....	14-gauge (0.075-inch) type 304 brushed stainless steel
Back box.....	16-gauge (0.060-inch) cold-rolled steel with black polyurethane finish

Dimensions

Front panel.....	8.5 H × 7.5 W in (215 × 190.5 mm)
Back box (overall)	7.62 H × 5.62 W × 2.37 D in (193.6 × 142.7 × 60.2 mm)
Cutout for flush mounting	7.75 H × 5.75 W in (196.9 × 146.1 mm)

Weight.....	5.0 lb (2.3 kg)
-------------	-----------------

Handset/cord	G-style with armored cord
--------------------	---------------------------

Approvals

Safety of Information Technology Equipment UL 60950 and CAN/CSA-C22.2 NO. 60950-00
 Enclosures for Electrical Equipment..... UL 50 TYPE 3R/NEMA 3R

FCC Information

FCC Registration Number US: ADGTE10A-46048HAC
 Ringer Equivalence Number (REN) 1.0A/1.3B
 Network Connection (USOC)..... RJ11
 Meets hearing aid compatibility magnetic field intensity and volume control technical standards per FCC Sections 68.316 and 68.317.

IC Information (Canada)

IC Certification Number 82211754
 Ringer Equivalence Number (REN) 1.0A/1.3B
 Connecting Method..... CA11A

User Instructions (USA)

This equipment has been tested and found to comply with the limits for a Class A digital device, pursuant to part 15 of the FCC Rules. These limits are designed to provide reasonable protection against harmful interference when the equipment is operated in a commercial environment. This equipment generates, uses, and can radiate radio frequency energy and, if not installed and used in accordance with the instruction manual, may cause harmful interference to radio communications. Operation of this equipment in a residential area is likely to cause harmful interference in which case the user will be required to correct the interference at his own expense.

This equipment complies with Part 68 of the FCC rules. Located on the equipment is a label that contains, among other information, the FCC registration number and REN (ringer equivalence number). If requested, this information must be provided to the telephone company. The REN is used to determine the quantity of devices which may be connected to the telephone line. Excessive REN's on the telephone line may result in the devices not ringing in response to an incoming call. In most, but not all areas, the sum of the REN's should not exceed five (5.0). To be certain of the number of devices that may be connected to the line, as determined by the total REN's contact the telephone company to determine the maximum REN for the calling area. This equipment cannot be used on the telephone company-provided coin service. Connection to Party Line Service is subject to State Tariffs. If this equipment causes harm to the telephone network, the telephone company will notify you in advance that temporary discontinuance of service may be required. If advance notice isn't practical, the telephone company will notify the customer as soon as possible. Also, you will be advised of your right to file a complaint with the FCC if you believe it is necessary. The telephone company may make changes in its facilities, equipment, operations, or procedures that could affect the operation of the equipment. If this happens, the telephone company will provide advance notice in order for you to make the necessary modifications in order to maintain uninterrupted service.



If trouble is experienced with this equipment, please contact:

GAI-Tronics Corporation
 400 E. Wyomissing Ave.
 Reading, PA 19540 USA
 800-492-1212 or 610-777-1374

If the trouble is causing harm to the telephone network, the telephone company may request you to remove the equipment from the network until the problem is resolved. This equipment uses the following USOC jacks: RJ11C. It is recommended that the customer install an ac surge arrester in the ac outlet to which this device is connected. This is to avoid damaging the equipment caused by local lightning strikes and other electrical surges. This equipment is HAC (Hearing-Aid Compatible). The telephone Consumer Protection Act of 1991 makes it unlawful for any person to use a computer or other electronic device, including fax machines, to send any message unless such message clearly contains in a margin at the top or bottom of each transmitted page or on the first page of the transmission, the date and time it is sent and an identification of the business or other entity, or other individual sending the message, and the telephone number of the sending machine or such business, other entity, or individual. (The telephone number provided may not be a 900 number or any other number for which charges exceed local or long-distance transmission charges.)

User Instructions (Canada) CP-01, Issue 8, Part I: Section 14.1

NOTICE: The Industry Canada label identifies certified equipment. This certification means that the equipment meets certain telecommunications network protective, operational, and safety requirements as prescribed in the appropriate Terminal Equipment Technical Requirements document (s). The Department does not guarantee the equipment will operate to the user's satisfaction. Before installing this equipment, users should ensure that it is permissible to be connected to the facilities of the local telecommunications company. The equipment must also be installed using an acceptable method of connection. The customer should be aware that compliance with the above conditions may not prevent degradation of service in some situations. Repairs to certified equipment should be coordinated by a representative designated by the supplier. Any repairs or alterations made by the user to this equipment, or equipment malfunctions, may give the telecommunications company cause to request the user to disconnect the equipment. Users should ensure for their own protection that the electrical ground connections of the power utility, telephone lines and internal metallic water pipe system, if present, are connected together. This precaution may be particularly important in rural areas.

 **CAUTION**  —Users should not attempt to make such connections themselves, but should contact the appropriate electric inspection authority, or electrician, as appropriate.

CP-01, Issue 8, Part I: Section 14.2

NOTICE: The **REN (Ringer Equivalence Number)** assigned to each terminal device provides an indication of the maximum number of terminals allowed to be connected to a telephone interface. The termination on an interface may consist of any combination of devices subject only to the requirement that the sum of the ringer equivalence numbers of all the devices does not exceed five.

Warranty

Equipment. GAI-Tronics warrants for a period of one (1) year from the date of shipment, that any GAI-Tronics equipment supplied hereunder shall be free of defects in material and workmanship, shall comply with the then-current product specifications and product literature, and if applicable, shall be fit for the purpose specified in the agreed-upon quotation or proposal document. If (a) Seller's goods prove to be defective in workmanship and/or material under normal and proper usage, or unfit for the purpose specified and agreed upon, and (b) Buyer's claim is made within the warranty period set forth above, Buyer may return such goods to GAI-Tronics' nearest depot repair facility, freight prepaid, at which time they will be repaired or replaced, at Seller's option, without charge to Buyer. Repair or replacement shall be Buyer's sole and exclusive remedy. The warranty period on any repaired or replacement equipment shall be the greater of the ninety (90) day repair warranty or one (1) year from the date the original equipment was shipped. In no event shall GAI-Tronics warranty obligations with respect to equipment exceed 100% of the total cost of the equipment supplied hereunder. Buyer may also be entitled to the manufacturer's warranty on any third-party goods supplied by GAI-Tronics hereunder. The applicability of any such third-party warranty will be determined by GAI-Tronics.

Services. Any services GAI-Tronics provides hereunder, whether directly or through subcontractors, shall be performed in accordance with the standard of care with which such services are normally provided in the industry. If the services fail to meet the applicable industry standard, GAI-Tronics will re-perform such services at no cost to buyer to correct said deficiency to Company's satisfaction provided any and all issues are identified prior to the demobilization of the Contractor's personnel from the work site. Re-performance of services shall be Buyer's sole and exclusive remedy, and in no event shall GAI-Tronics warranty obligations with respect to services exceed 100% of the total cost of the services provided hereunder.

Warranty Periods. Every claim by Buyer alleging a defect in the goods and/or services provided hereunder shall be deemed waived unless such claim is made in writing within the applicable warranty periods as set forth above. Provided, however, that if the defect complained of is latent and not discoverable within the above warranty periods, every claim arising on account of such latent defect shall be deemed waived unless it is made in writing within a reasonable time after such latent defect is or should have been discovered by Buyer.

Limitations / Exclusions. The warranties herein shall not apply to, and GAI-Tronics shall not be responsible for, any damage to the goods or failure of the services supplied hereunder, to the extent caused by Buyer's neglect, failure to follow operational and maintenance procedures provided with the equipment, or the use of technicians not specifically authorized by GAI-Tronics to maintain or service the equipment. **THE WARRANTIES AND REMEDIES CONTAINED HEREIN ARE IN LIEU OF AND EXCLUDE ALL OTHER WARRANTIES AND REMEDIES, WHETHER EXPRESS OR IMPLIED BY OPERATION OF LAW OR OTHERWISE, INCLUDING ANY WARRANTIES OF MERCHANTABILITY OR FITNESS FOR A PARTICULAR PURPOSE.**

Return Policy

If the equipment requires service, contact your Regional Service Center for a return authorization number (RA#). Equipment should be shipped prepaid to GAI-Tronics with a return authorization number and a purchase order number. If the equipment is under warranty, repairs or a replacement will be made in accordance with the warranty policy set forth above. Please include a written explanation of all defects to assist our technicians in their troubleshooting efforts.

Call 800-492-1212 (inside the USA) or 610-777-1374 (outside the USA) for help identifying the Regional Service Center closest to you.