



GAI-TRONICS®
A HUBBELL COMPANY

Model 226-002, 341-001, and 351-001 Div. 2 Industrial Telephones

TABLE OF CONTENTS

Confidentiality Notice 1

General Information 1

Installation Guidelines..... 1

 User Instructions (USA) 3

 User Instructions (Canada) CP-01, Issue 8, Part I: Section 14.1..... 3

 CP-01, Issue 8, Part I: Section 14.2 3

Installation 4

 Safety Guidelines..... 4

 Security Hardware..... 4

 Conduit Installation Details (applicable to Models 341-001 & 351-001)..... 4

 Model 226-002 6

 Model 341-001 8

 Model 351-001 10

Operation..... 12

 Volume Control Jumper Setting..... 12

Specifications 12

 Replacement Parts & Accessories 14



GAI-TRONICS®
A HUBBELL COMPANY

Model 226-002, 341-001, and 351-001 Div. 2 Industrial Telephones

Confidentiality Notice

This manual is provided solely as an installation, operation, and maintenance guide and contains sensitive business and technical information that is confidential and proprietary to GAI-Tronics. GAI-Tronics retains all intellectual property and other rights in or to the information contained herein, and such information may only be used in connection with the operation of your GAI-Tronics product or system. This manual may not be disclosed in any form, in whole or in part, directly or indirectly, to any third party.

General Information

GAI-Tronics Div. 2 Industrial Telephones are designed for applications where standard telephones could cause a hazardous condition. These industrial-strength telephones are ideally suited for conditions that are too harsh for a standard telephone. The telephones operate the same as a standard telephone—simply lift the handset and dial the desired telephone number. The telephones are fully line-powered and do not require internal batteries.

Installation Guidelines

When installing any GAI-Tronics telephone equipment, please adhere to the following guidelines to ensure the safety of all personnel:

- NEVER install telephone wiring during a lightning storm.
- **Install a UL Listed lightning arrester** on any telephone installed where the telephone or telephone cable is at risk of being exposed to lightning strikes. The lightning arrester must be installed as close to the telephone as possible to maximize the protection. The lightning arrester must not be installed within the enclosure supplied with the telephone.
- NEVER install telephone jacks in wet locations unless the jack is specifically designed for wet locations.
- NEVER touch uninsulated telephone wires or terminals unless the telephone line has been disconnected at the network interface.
- USE CAUTION when installing or modifying telephone lines.
- Install UL Listed telephone line suppressor (customer-supplied) on the telephone line.
- Use silicone sealant or equivalent around and inside all conduit entries

GAI-Tronics recommends the following precautionary steps to protect the unit during installation:

1. Install this unit using appropriate Div. 2 wiring methods.
2. To ensure that the unit is vandal-resistant, run the subscriber line inside conduit.
3. Use the conduit entry located on the bottom of the enclosure to prevent any condensation forming inside the conduit from dripping into the unit. Additionally, using the bottom conduit entry makes water less likely to enter the unit at the conduit connection points.
4. Use Teflon™ pipe joint tape or a thread sealing compound around the conduit threads to seal threaded connections and prevent water from entering into the unit at the conduit location.
5. Apply a small amount of silicone sealant inside and around the end of the conduit pipe that is inside the unit. The sealant helps to prevent any condensation formed inside the conduit from dripping into the unit. This is especially important when using the conduit entry located on the top of the enclosure. (Manufacturers of silicon sealant include: Dow Corning, Duron, General Electric, and DuPont.)
6. Sealed fittings should be installed at all cable entry points to prevent liquids from entering the unit.

User Instructions (USA)

This equipment has been tested and found to comply with the limits for a Class A digital device, pursuant to part 15 of the FCC Rules. These limits are designed to provide reasonable protection against harmful interference when the equipment is operated in a commercial environment. This equipment generates, uses, and can radiate radio frequency energy and, if not installed and used in accordance with the instruction manual, may cause harmful interference to radio communications. Operation of this equipment in a residential area is likely to cause harmful interference in which case the user will be required to correct the interference at his own expense.

This equipment complies with Part 68 of the FCC rules. Located on the equipment is a label that contains, among other information, the FCC registration number and ringer equivalence number (REN). If requested, this information must be provided to the telephone company. The REN is used to determine the quantity of devices which may be connected to the telephone line. Excessive REN's on the telephone line may result in the devices not ringing in response to an incoming call. In most, but not all areas, the sum of the REN's should not exceed five (5.0). To be certain of the number of devices that may be connected to the line, as determined by the total REN's contact the telephone company to determine the maximum REN for the calling area. This equipment cannot be used on the telephone company-provided coin service. Connection to Party Line Service is subject to State Tariffs. If this equipment causes harm to the telephone network, the telephone company will notify you in advance that temporary discontinuance of service may be required. If advance notice isn't practical, the telephone company will notify the customer as soon as possible. Also, you will be advised of your right to file a complaint with the FCC if you believe it is necessary. The telephone company may make changes in its facilities, equipment, operations, or procedures that could affect the operation of the equipment. If this happens, the telephone company will provide advance notice in order for you to make the necessary modifications in order to maintain uninterrupted service.

If trouble is experienced with this equipment, please contact:

GAI-Tronics Corporation
400 E. Wyomissing, Ave.
Mohnton, PA 19540 USA
800-492-1212 or 610-777-1374

If the trouble is causing harm to the telephone network, the telephone company may request you to remove the equipment from the network until the problem is resolved. This equipment uses the following USOC jacks: RJ11C It is recommended that the customer install an ac surge arrester in the ac outlet to which this device is connected. This is to avoid damaging the equipment caused by local lightning strikes and other electrical surges. This equipment is Hearing-Aid Compatible (HAC). The telephone Consumer Protection Act of 1991 makes it unlawful for any person to use a computer or other electronic device, including fax machines, to send any message unless such message clearly contains in a margin at the top or bottom of each transmitted page or on the first page of the transmission, the date and time it is sent and an identification of the business or other entity, or other individual sending the message and the telephone number of the sending machine or such business, other entity, or individual. (The telephone number provided may not be a 900 number or any other number for which charges exceed local or long-distance transmission charges.)

User Instructions (Canada) CP-01, Issue 8, Part I: Section 14.1

NOTICE: The Industry Canada label identifies certified equipment. This certification means that the equipment meets certain telecommunications network protective, operational and safety requirements as prescribed in the appropriate Terminal Equipment Technical Requirements document (s). The Department does not guarantee the equipment will operate to the user's satisfaction. Before installing this equipment, users should ensure that it is permissible to be connected to the facilities of the local telecommunications company. The equipment must also be installed using an acceptable method of connection. The customer should be aware that compliance with the above conditions may not prevent degradation of service in some situations. Repairs to certified equipment should be coordinated by a representative designated by the supplier. Any repairs or alterations made by the user to this equipment, or equipment malfunctions, may give the telecommunications company cause to request the user to disconnect the equipment. Users should ensure for their own protection that the electrical ground connections of the power utility, telephone lines and internal metallic water pipe system, if present, are connected together. This precaution may be particularly important in rural areas.





Users should not attempt to make such connections themselves, but should contact the appropriate electric inspection authority, or electrician, as appropriate.

CP-01, Issue 8, Part I: Section 14.2

NOTICE: The **Ringer Equivalence Number** (REN) assigned to each terminal device provides an indication of the maximum number of terminals allowed to be connected to a telephone interface. The termination on an interface may consist of any combination of devices subject only to the requirement that the sum of the Ringer Equivalence Numbers of all the devices does not exceed 5.

Installation

 **WARNING**  **This product can contain hazardous voltages. Always remove power to this station and any associated equipment before beginning any installation.**

 **CAUTION**  **Do not install this equipment in areas other than those indicated on the approval listing in the “Specifications” section of this manual. Such installation may cause a safety hazard and consequent injury or property damage.**

Install equipment without modification and according to all applicable local and national electrical codes. Consult the National Electrical Code (NFPA 70), Canadian Standards Association (CSA 22.1), and local codes for specific requirements regarding your installation. Class 2 circuit wiring must be performed in accordance with NEC 725.55.

Safety Guidelines

When installing any GAI-Tronics equipment, please adhere to the following guidelines to ensure the safety of all personnel:

- Do not install wiring during a lightning storm.
- A Cat5 data line lightning surge protector is recommended for telephones subject to any electrostatic discharge (e.g. lightning)
- Do not install jacks in wet locations unless the jack is specifically designed for wet locations.

Security Hardware

The Model 226-002 is vandal-resistant, with the front panel attached to its enclosure with security screws. A GAI-Tronics Model 233-001 Security Screwdriver or Torx T-25 security head tip (sold separately) is recommended for installing the security screws. Models 341-001 and 351-001 Telephones' front panels are attached with standard Phillips head screws.

Conduit Installation Details (applicable to Models 341-001 & 351-001)

GAI-Tronics recommends installing telephone lines in conduit to protect against accidental damage and vandalism and to meet applicable Div. 2 installation requirements. To prevent moisture from entering the enclosure, we strongly recommend the following:

- Conduit should enter the enclosure from the bottom.
- If entered from the top, the conduit must be internally sealed to prevent moisture ingress.
- Sealed fittings should be installed at all cable entry points.
- **Silicone sealant or equivalent must be applied around and inside all conduit entries.**

Please refer to Figure 1 and Figure 2.

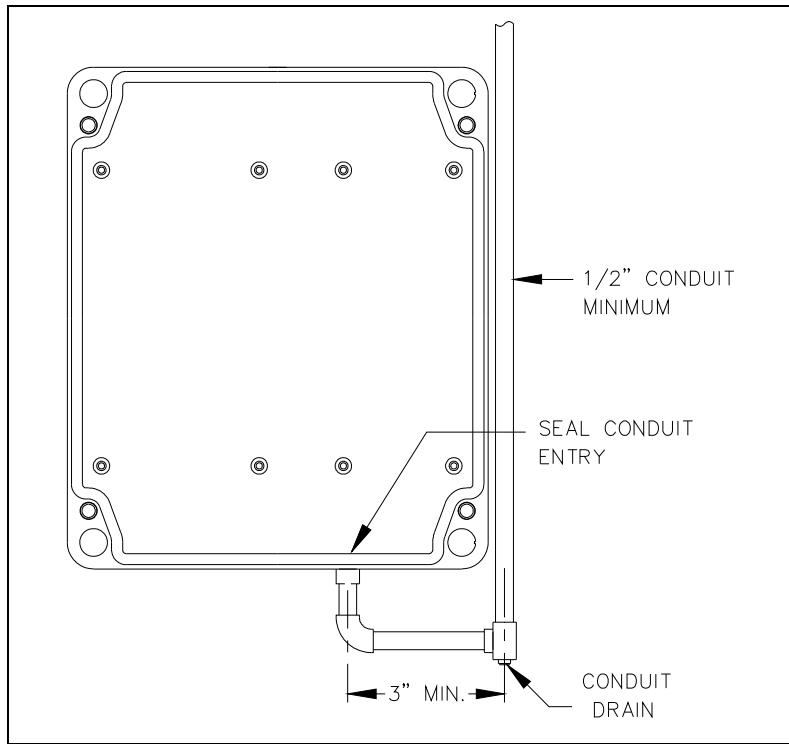

Figure 1. Bottom entry conduit installation details (RECOMMENDED for non-metallic enclosures)

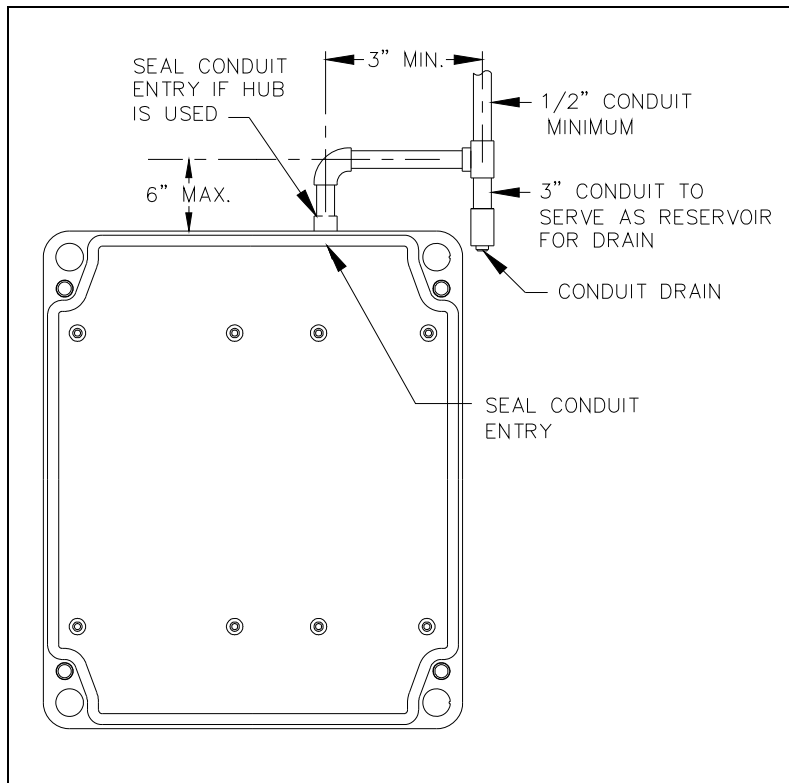

Figure 2. Top entry conduit installation details (NOT RECOMMENDED)

Model 226-002

Mounting and wiring of the Model 226-002 must be in accordance with Div. 2 installation standard practices.

1. Use a GAI-Tronics Model 233-001 Screwdriver to loosen the eight front panel security screws.
2. Remove the front panel assembly to expose the eight mounting holes. These holes accept 3/8-inch diameter bolts. The length of these bolts depends on the mounting surface.
 - *For wider and retrofit hole patterns from the Northern Telecom Model NE-2525Q Series, use the 7.875 × 4.00-inch hole pattern. Four hole plugs are supplied for the unused holes.*

When using the Model 232-001 Pole Mounting Kit, use the 5.25 × 4.00-inch hole pattern. This kit includes four 3/8-16 × 1-inch shoulder bolts with Teflon™ seal washers. For additional support in wood poles, use 3/8-inch or 1/2-inch lug bolts with washers (not included).

 - *For wall-mount applications, mount directly to the wall or use Model 232-001 Pole Mounting Kit and 3/8 inch or 1/2 inch lug bolts with washers. (NOTE: Lug bolts with washers are not included in the kit).*
3. A 1/2-NPT conduit entrance is provided at both the top and the bottom of the unit. An Allen drive plug is supplied for the unused entry.

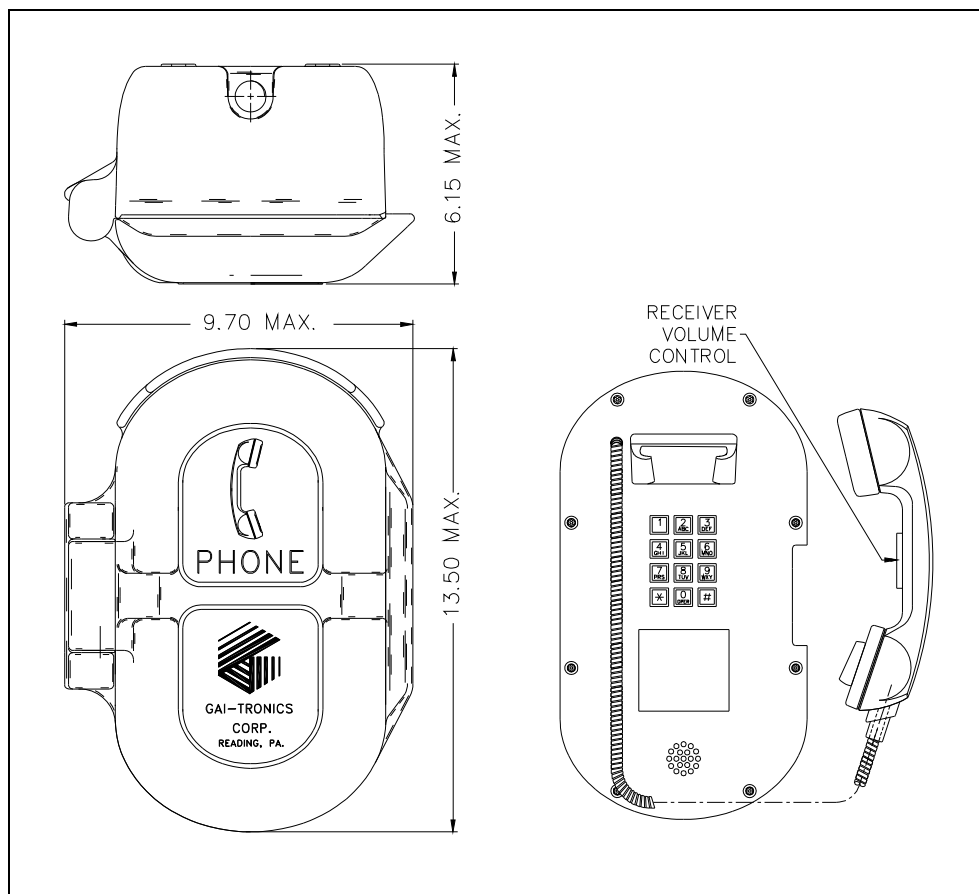
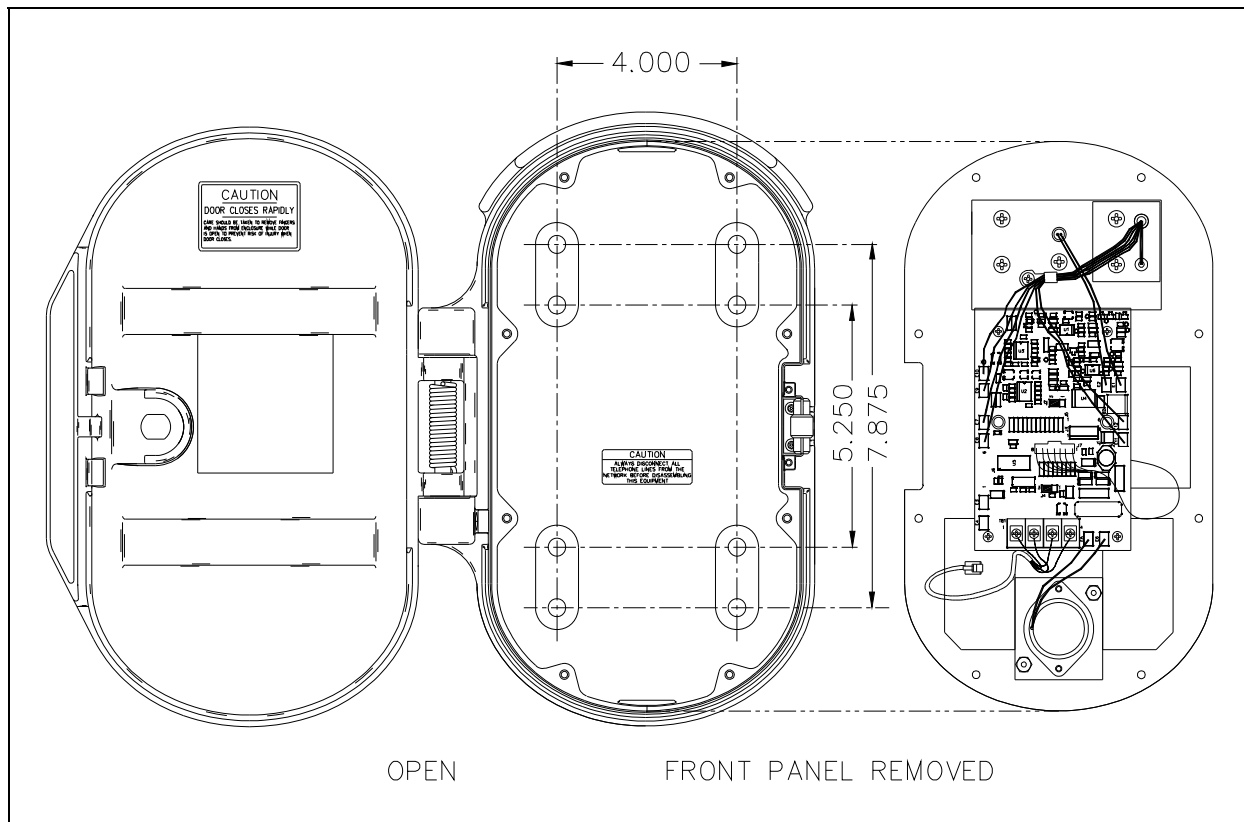

Figure 3. Model 226-002 Outline Drawing

4. Connect the free end of the modular telephone cord to the incoming subscriber line using the appropriate mating connector or connect the incoming line directly to the terminal strip.
5. Replace the front panel assembly and tighten the eight front panel screws.
6. Check the telephone operation by calling to and from another telephone.



Model 341-001

Mounting and wiring of the Model 341-001 must be in accordance with Div. 2 installation standard practices.

1. Remove the four front panel screws using a standard Phillips screwdriver, and remove the front panel assembly and set aside.

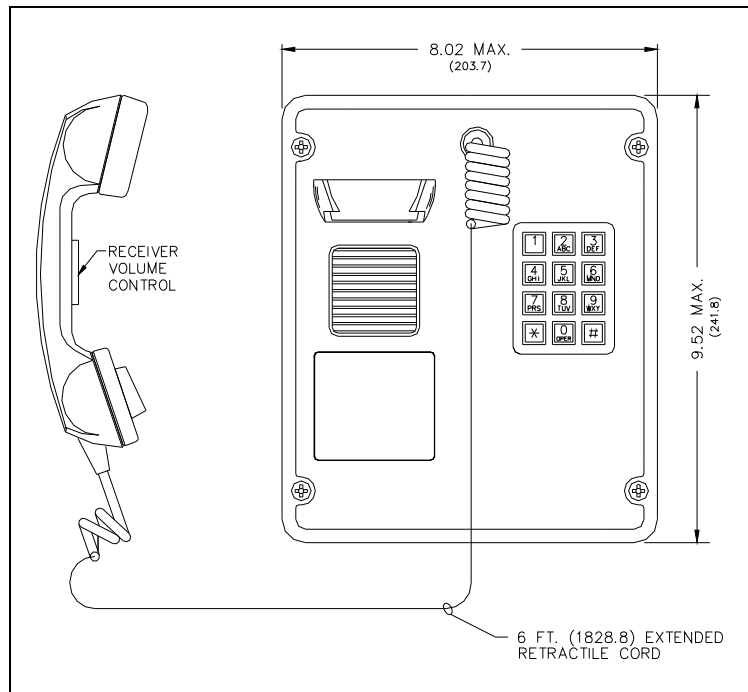

Figure 5. Model 341-001 Outline Drawing

2. There are four mounting holes in the rear enclosure. Mount the enclosure to the wall using either four 1/4-20 machine screws with nuts and washers, or #14 wood screws of appropriate length for the mounting surface. Refer to Figure 7.
3. Enter the rear enclosure with telephone wiring per accepted Div. 2 standards.

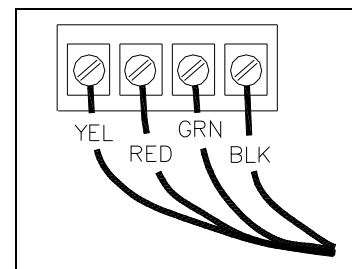

Figure 6. PCBA Connection

4. Connect the telephone cord's modular connector to the incoming subscriber line using the appropriate mating connector or connect the incoming line directly to the terminal strip. See Figure 6.
5. Replace the front panel assembly, and secure with the four front panel screws.
6. Check for proper telephone operation by calling to and from another telephone.

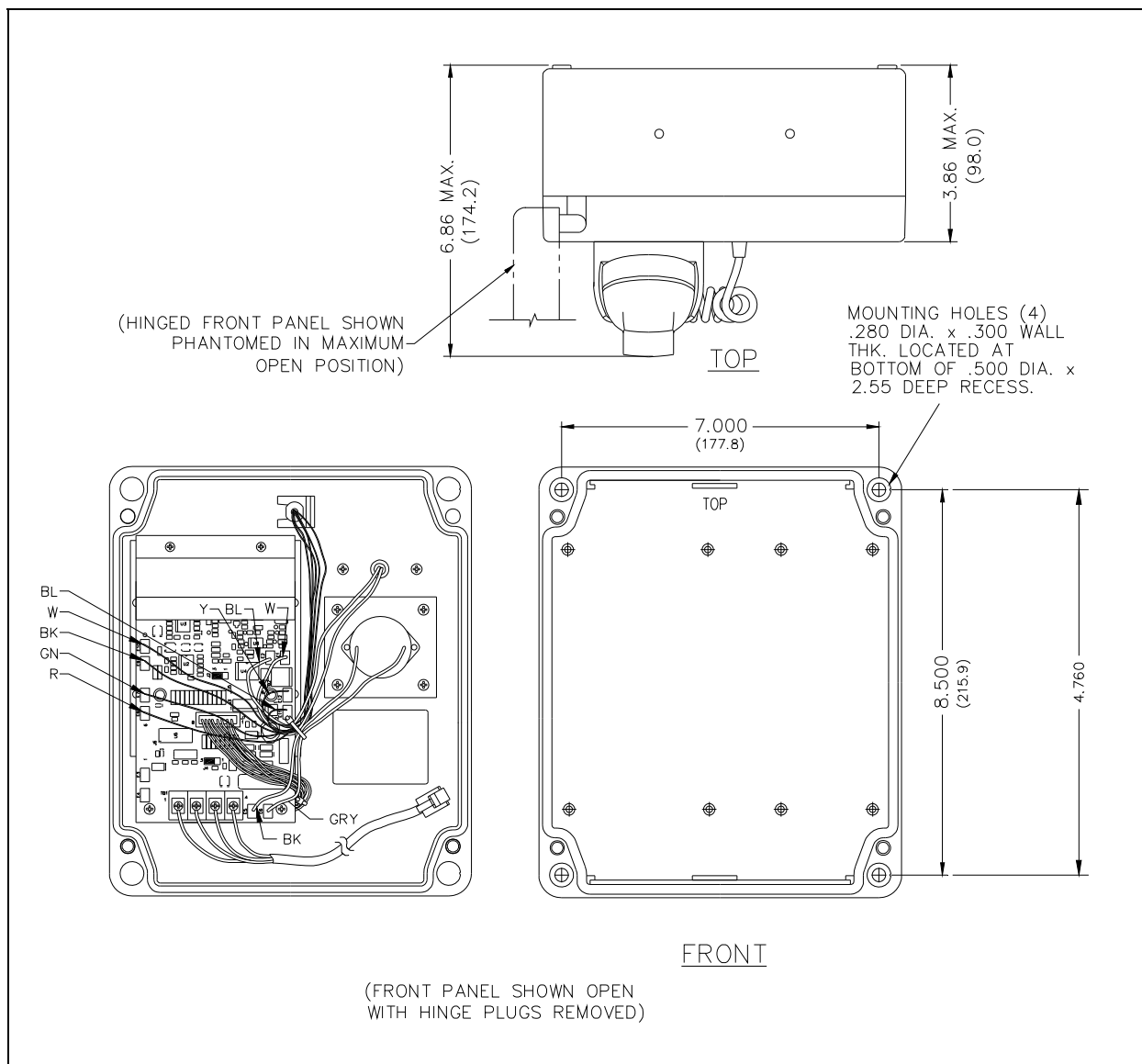

Figure 7. Model 341-001 Mounting Diagram

Model 351-001

Mounting and wiring of the Model 351-001 must be in accordance with Div. 2 installation standard practices.

1. Open the front door of the enclosure. Locate the four outermost screws.
2. Remove the four outermost screws, and carefully pull the enclosure apart until encountering a slight resistance on the left side.

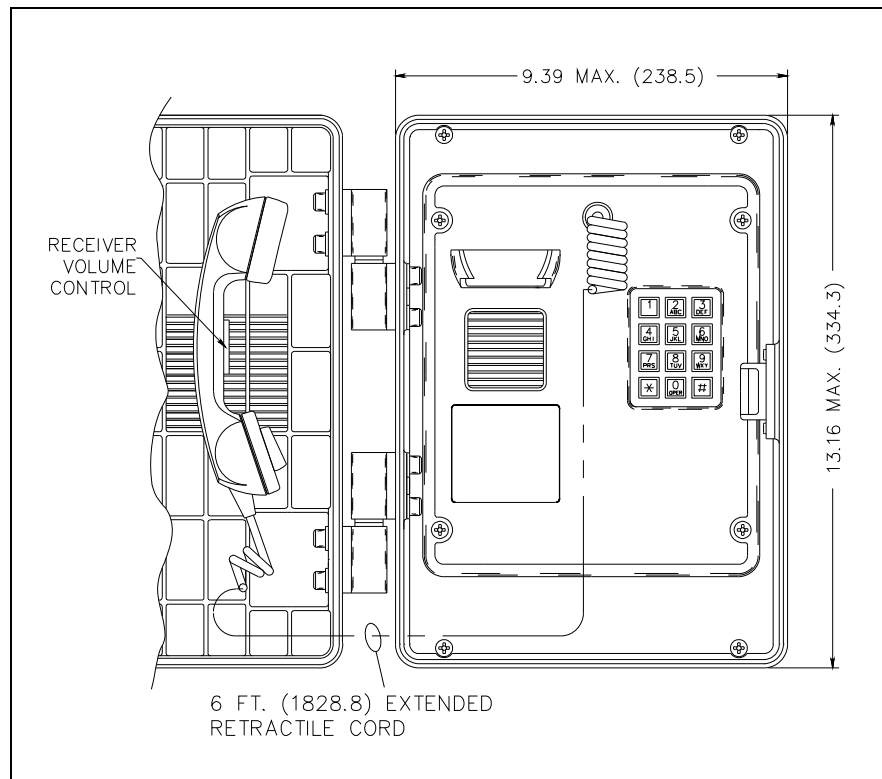

Figure 8. Model 351-001 Outline Drawing

3. Open the front half of the enclosure to the left.
4. Pull on the left side of the enclosure until the hinge plugs pull loose to separate the front half from the rear half. Set the front half of the enclosure aside.
5. Mount the enclosure on the wall using four 1/4-20 machine screws with nuts and washers or #14 wood screws of appropriate length, depending on the mounting surface.
6. Enter the rear enclosure with telephone wiring per accepted Div. 2 standards.
7. Insert the front half of the telephone hinges into the rear enclosure, remaining open to the left.
8. Connect the telephone cord's modular connector to the incoming subscriber line using the appropriate mating connector or connect the incoming line directly to the terminal strip per Figure 6

- 9. Close the front half of the enclosure, and secure it by replacing the four outermost screws.
- 10. Check for proper telephone operation by calling to and from another telephone.

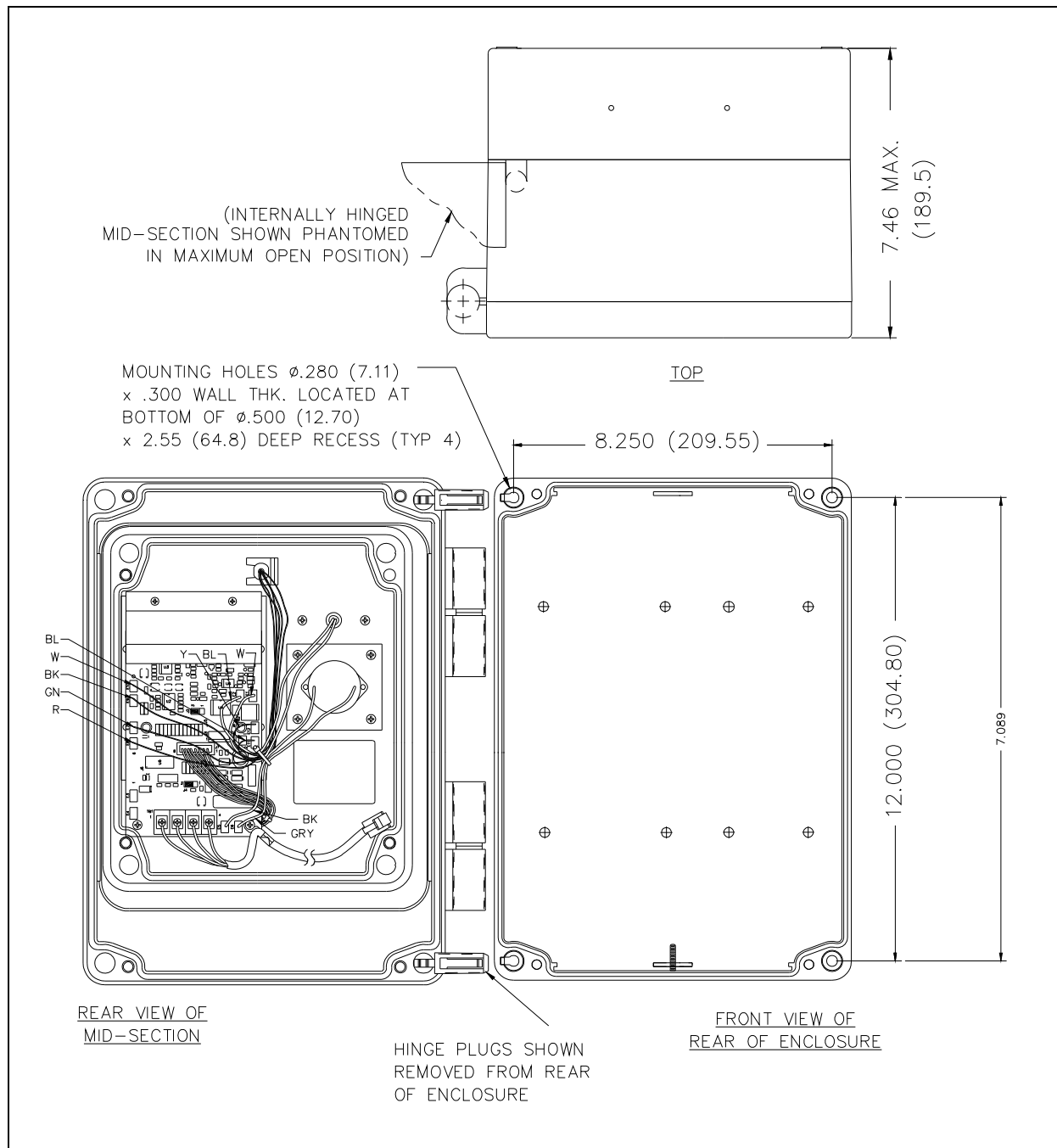

Figure 9. Model 351-001 Mounting Detail

Operation

1. Lift the handset to place a call.
2. The handset receiver volume control, which is located on the handset, can be adjusted to the desired level by pressing the handset pressbar.
NOTE: Pressing the handset pressbar increases the volume in 3 dB increments. The volume starts at 0 dB and increases to a maximum of 18 dB. Pressing the pressbar a seventh time returns the volume to 0 dB.
3. Dial the desired number. After completion of the call, place the handset on-hook.

Volume Control Jumper Setting

The handset receiver volume control is factory-set to default to its original setting (0 dB) when the telephone is hung up. To save the volume control setting, jumper **J4**, which is factory-set at positions **2** and **3**, must be moved to positions **1** and **2**.

Specifications

Electrical (Typical)

| | |
|------------------------------|---|
| Frequency response..... | 300 to 3,000 Hz |
| Inter-digit pause | 100 ms |
| Minimum loop current | 20 mA |
| Operation | Loop start |
| Signaling tone (DTMF)..... | 100 ms tone duration |
| Supervisory dc current | Minimum 20 mA dc; maximum .60 mA dc |
| Supervisory dc voltage..... | 24 V dc to 60 V dc (not polarity sensitive) |
| Network interface..... | Loop start |
| Minimum loop center..... | 20 mA |
| Network signaling..... | DTMF |

Environmental

| | |
|-----------------------------|--------------------------------------|
| Operating temperature | -40° F to +140° F (-40° C to +60° C) |
| Humidity | 90% non-condensing |

FCC Information

| | |
|---|-----------------------|
| FCC Registration Number | US: ADGTE10A-46048HAC |
| Ringer Equivalence Number (REN) | 1.0A/1.3B |
| Network connection (USOC)..... | RJ11 |
| Meets hearing aid compatibility magnetic field intensity and volume control technical standards per FCC Sections 68.316 and 68.317. | |

IC Information (Canada)

| | |
|---------------------------------------|-----------|
| IC Certification Number | 82211754 |
| Ringer Equivalence Number (REN) | 1.0A/1.3B |
| Connecting Method..... | CA11A |

Model 226-002 - Mechanical

Enclosure Thick-walled cast aluminum
 Finish Gray polyurethane enamel
 Handset/cord "G" style with armored cord and volume switch
 Dial Pad, Braille Chrome-plated zinc
 Front panel 0.125-inch brushed anodized aluminum
 Hookswitch Chrome-plated zinc, stationary switching mechanism

Model 341-001 - Mechanical

Enclosure High-impact, glass-reinforced polyester
 Handset cord "G" style handset/Hytrel[®] 6-foot extended length (standard) and volume switch
 Connections 6.5-foot (1.98 m) modular line cord
 Dimensions, outside 8.0 W × 9.5 H × 6.9 D inches (204 × 242 × 174 mm)
 Mounting Four 0.280-inch diameter holes
 Weight 6.0 lbs. (2.7 kg)

Model 351-001 - Mechanical

Enclosure High-impact, glass-reinforced polyester
 Handset cord "G" style handset/Hytrel[®] 6-foot extended length (standard) and volume switch
 Connections 6.5-foot (1.98 m) modular line cord
 Dimensions, outside 9.4 W × 13.2 H × 7.4 D inches (239 × 334 × 189 mm)
 Mounting Four 0.280-inch diameter holes
 Weight 8.2 lbs. (3.72 kg)

Hazardous Area Approvals

Class I, Division 2, Groups A, B, C, D ANSI/ISA 12.12.01/ CSA - C22.2 No. 157
 Class II, Division 2, Groups F and G; Class III ANSI/ISA 12.12.01/ CSA - C22.2 No. 157
 Safety of Information Technology Equipment UL 508 & CAN/CSA-C22.2 No. 60950-00
 Enclosures for Electrical Equipment UL 50 TYPE 3R/NEMA 3R

Replacement Parts & Accessories

| Part No. | Description | 226-002 | 341-001 | 351-001 |
|------------|--|---------|---------|---------|
| | Replacement Parts | | | |
| 10111-101 | Handset Assembly with 6-foot Hytel [®] Coiled Cord, Volume Control, and Noise-Canceling | | ■ | |
| 10111-104 | Handset Assembly | | | ■ |
| 10117-001 | Handset Assembly with 15-inch Armored Cord, Volume Control, and Noise-Canceling | ■ | | |
| 12512-001 | Proximity-Detecting Hookswitch/Cradle Kit | | ■ | ■ |
| 12512-002 | Hookswitch/Cradle Kit | ■ | | |
| 12516-001 | Replacement Mounting Screw Kit (Phillips, 10 pack) | | ■ | ■ |
| 12542-002 | Replacement Mounting Screw Kit (Security, 15 pack) | ■ | | |
| 13707-004 | Replacement Ringer Assembly | ■ | ■ | ■ |
| 12513-003 | Interior Hinge Pins | | | ■ |
| 51035-005A | Replacement Keypad Assembly, Braille | ■ | ■ | ■ |
| 61504-048 | Keypad Cable Assembly | ■ | ■ | ■ |
| 69147-104 | PCBA Replacement Kit | ■ | ■ | ■ |
| | Accessories | | | |
| 230-001 | Pole Mounting Kit | | | ■ |
| 231-001 | Pole Mounting Kit | | ■ | |
| 232-001 | Pole Mounting Kit | ■ | | |
| 233-001 | Security Screwdriver, Torx T-25 Tip | ■ | | |

Warranty

Equipment. GAI-Tronics warrants for a period of one (1) year from the date of shipment, that any GAI-Tronics equipment supplied hereunder shall be free of defects in material and workmanship, shall comply with the then-current product specifications and product literature, and if applicable, shall be fit for the purpose specified in the agreed-upon quotation or proposal document. If (a) Seller's goods prove to be defective in workmanship and/or material under normal and proper usage, or unfit for the purpose specified and agreed upon, and (b) Buyer's claim is made within the warranty period set forth above, Buyer may return such goods to GAI-Tronics' nearest depot repair facility, freight prepaid, at which time they will be repaired or replaced, at Seller's option, without charge to Buyer. Repair or replacement shall be Buyer's sole and exclusive remedy. The warranty period on any repaired or replacement equipment shall be the greater of the ninety (90) day repair warranty or one (1) year from the date the original equipment was shipped. In no event shall GAI-Tronics warranty obligations with respect to equipment exceed 100% of the total cost of the equipment supplied hereunder. Buyer may also be entitled to the manufacturer's warranty on any third-party goods supplied by GAI-Tronics hereunder. The applicability of any such third-party warranty will be determined by GAI-Tronics.

Services. Any services GAI-Tronics provides hereunder, whether directly or through subcontractors, shall be performed in accordance with the standard of care with which such services are normally provided in the industry. If the services fail to meet the applicable industry standard, GAI-Tronics will re-perform such services at no cost to buyer to correct said deficiency to Company's satisfaction provided any and all issues are identified prior to the demobilization of the Contractor's personnel from the work site. Re-performance of services shall be Buyer's sole and exclusive remedy, and in no event shall GAI-Tronics warranty obligations with respect to services exceed 100% of the total cost of the services provided hereunder.

Warranty Periods. Every claim by Buyer alleging a defect in the goods and/or services provided hereunder shall be deemed waived unless such claim is made in writing within the applicable warranty periods as set forth above. Provided, however, that if the defect complained of is latent and not discoverable within the above warranty periods, every claim arising on account of such latent defect shall be deemed waived unless it is made in writing within a reasonable time after such latent defect is or should have been discovered by Buyer.

Limitations / Exclusions. The warranties herein shall not apply to, and GAI-Tronics shall not be responsible for, any damage to the goods or failure of the services supplied hereunder, to the extent caused by Buyer's neglect, failure to follow operational and maintenance procedures provided with the equipment, or the use of technicians not specifically authorized by GAI-Tronics to maintain or service the equipment. **THE WARRANTIES AND REMEDIES CONTAINED HEREIN ARE IN LIEU OF AND EXCLUDE ALL OTHER WARRANTIES AND REMEDIES, WHETHER EXPRESS OR IMPLIED BY OPERATION OF LAW OR OTHERWISE, INCLUDING ANY WARRANTIES OF MERCHANTABILITY OR FITNESS FOR A PARTICULAR PURPOSE.**

Return Policy

If the equipment requires service, contact your Regional Service Center for a return authorization number (RA#). Equipment should be shipped prepaid to GAI-Tronics with a return authorization number and a purchase order number. If the equipment is under warranty, repairs or a replacement will be made in accordance with the warranty policy set forth above. Please include a written explanation of all defects to assist our technicians in their troubleshooting efforts.

Call 800-492-1212 (inside the USA) or 610-777-1374 (outside the USA) for help identifying the Regional Service Center closest to you.