



GAI-TRONICS®  
A HUBBELL COMPANY

# Model ACC2500 Audio Control Center User and Installation Manual

---



## CONFIDENTIALITY NOTICE

This manual is provided solely as an operational, installation, and maintenance guide and contains sensitive business and technical information that is confidential and proprietary to GAI-Tronics. GAI-Tronics retains all intellectual property and other rights in or to the information contained herein, and such information may only be used in connection with the operation of your GAI-Tronics product or system. This manual may not be disclosed in any form, in whole or in part, directly or indirectly, to any third party.

## COMPUTER SOFTWARE COPYRIGHTS

This product contains copyrighted computer programs stored in semiconductor memory. These programs are copyrighted by GAI-Tronics Corporation and may not be reproduced in any form without express written permission from GAI-Tronics.

## WARRANTY

GAI-Tronics warrants for a period of one (1) year from the date of shipment, that any GAI-Tronics equipment supplied hereunder shall be free of defects in material and workmanship, shall comply with the then-current product specifications and product literature, and if applicable, shall be fit for the purpose specified in the agreed-upon quotation or proposal document. If (a) Seller's goods prove to be defective in workmanship and/or material under normal and proper usage, or unfit for the purpose specified and agreed upon, and (b) Buyer's claim is made within the warranty period set forth above, Buyer may return such goods to GAI-Tronics' nearest depot repair facility, freight prepaid, at which time they will be repaired or replaced, at Seller's option, without charge to Buyer. Repair or replacement shall be Buyer's sole and exclusive remedy, and the warranty period on any repaired or replacement equipment shall be one (1) year from the date the original equipment was shipped. In no event shall GAI-Tronics' warranty obligations with respect to equipment exceed 100% of the total cost of the equipment supplied hereunder. The applicability of any such third-party warranty will be determined solely by GAI-Tronics.

**Services.** Any services GAI-Tronics provides hereunder, whether directly or through subcontractors, shall be performed in accordance with the standard of care with which such services are normally provided in the industry. If the services fail to meet the applicable industry standard, GAI-Tronics will, for a period of one (1) year from the date of completion, re-perform such services at no cost to the Buyer. Re-performance of services shall be Buyer's sole and exclusive remedy, and in no event shall GAI-Tronics' warranty obligations with respect to services exceed 100% of the total cost of services provided hereunder.

**Limitations/Exclusions.** The warranty on any equipment supplied hereunder is subject to Customer's use in compliance with applicable FCC regulations and manufacturer specifications. The warranties herein shall not apply to, and GAI-Tronics shall not be responsible for, any damage to the goods or failure of the services supplied hereunder, to the extent caused by accident, misuse, abuse, neglect, system design, product modification, failure to follow instructions contained in the product manual, repair, or attempted repair by anyone not authorized by GAI-Tronics, improper installation, installation of parts that do not conform to the quality or specifications of the original parts or accessories, damage or loss occurred during shipment, or any unit which is not new when sold or upon which the serial number has been defaced, modified or removed. The warranty does not extend to damage incurred by natural causes including Force Majeure. The warranty does not cover microprocessors if failure is due to static damage or application of improper voltage. **THE WARRANTIES AND REMEDIES CONTAINED HEREIN ARE IN LIEU OF AND EXCLUDE ALL OTHER WARRANTIES AND REMEDIES, WHETHER EXPRESS OR IMPLIED BY OPERATION OF LAW OR OTHERWISE, INCLUDING ANY WARRANTIES OF MERCHANTABILITY OR FITNESS FOR A PARTICULAR PURPOSE.**

**Operational and Maintenance Procedures.** Buyer acknowledges that any improper use, maintenance, or modification of the equipment provided hereunder, or use of unqualified maintenance or service technicians will severely impair the operational effectiveness of the entire communication system. Buyer hereby agrees to indemnify, defend and hold GAI-Tronics harmless from and against any and all third party claims arising, in any manner, out of: (a) Buyer's neglect of the equipment; (b) Buyer's use of technicians not authorized by GAI-Tronics to service the equipment; or (c) Buyer's improper use or modification of the equipment or failure to follow the operational and maintenance procedures provided with the equipment.

**Limitation of Liability/Damages.** In no event (even should circumstances cause the exclusive warranties and remedies set forth in the Warranty section to fail of their essential purpose) shall either party be liable for any indirect, incidental, special or consequential damages (including, but not limited to, loss of use, loss of anticipated profits, or damages arising from delay) whether such claims are alleged to have arisen out of breach of warranty, breach of contract, strict or absolute liability in tort, or other act, error or omission, or from any other cause whatsoever, or any combination of the foregoing.

# Table of Contents

---

<b>FOREWORD .....</b>	<b>1</b>
SCOPE OF MANUAL.....	1
NOMENCLATURE.....	1
ORDERING REPLACEMENT PARTS.....	1
SERVICE AND REPAIR .....	1
FCC INTERFERENCE WARNING .....	1
SAFE HANDLING OF CMOS INTEGRATED CIRCUIT DEVICES .....	2
<b>DESCRIPTION.....</b>	<b>3</b>
FEATURES AND BENEFITS .....	3
INTRODUCTION TO THE ACC2500 AUDIO CONTROL CENTER .....	4
SYSTEM COMPONENT REFERENCES .....	4
DESK SET BUTTON PANEL .....	5
INTERNAL MICROPHONE AND SPEAKER .....	6
HANDSET.....	6
CONNECTORS.....	7
<i>Power Connector</i> .....	7
<i>AMI Connections</i> .....	7
ACCESSORIES, AND OPTIONS AND KITS .....	9
PERFORMANCE SPECIFICATIONS.....	10
<b>OPERATION .....</b>	<b>11</b>
DISPLAY .....	11
IDLE MODE.....	12
ZONE SELECTION .....	12
INITIATING LIVE VOICE BROADCASTS WITHOUT AN ALARM .....	13
<i>Handset Transmit</i> .....	14
<i>Transmit from Internal (Local) Microphone</i> .....	14
<i>Transmit from Desk Microphone or Footswitch</i> .....	14
ALARM SELECTION .....	15
INITIATING ALARM BROADCASTS WITHOUT VOICE .....	16
STOPPING THE BROADCAST OF AN ALARM.....	17
STOP/CLR vs. DEACT.....	17
INITIATING LIVE VOICE BROADCAST DURING AN ALARM BROADCAST .....	18
OVERDIALING DTMF.....	18
PROGRAMMABLE BUTTONS.....	19
VOLUME UP AND VOLUME DOWN BUTTONS .....	19
COMBINATION BUTTON OPERATION.....	20
TIME BUTTON .....	20
<b>INSTALLATION .....</b>	<b>21</b>
PLANNING THE INSTALLATION .....	21
<i>Mounting</i> .....	22
<i>FCC Interference Warnings</i> .....	22
<i>Electrostatic Discharge (ESD) Protection</i> .....	22
<i>Cable Installation Safety Considerations</i> .....	23
POWER CONNECTION .....	23
AUDIO AND DATA CONNECTION .....	23
MICROPHONE SENSITIVITY ADJUSTMENTS .....	24
<i>Internal Microphone Sensitivity</i> .....	24
<i>Handset Microphone Sensitivity</i> .....	24
LEVEL ADJUSTMENTS AND DIAGNOSTICS .....	25
<i>Programming Menu</i> .....	25

<i>Reloading Factory Defaults</i> .....	25
<i>Main Diagnostics Selection</i> .....	26
<i>PB1 – Line Output Adjust</i> .....	26
<i>PB2 - Line-In Sensitivity</i> .....	27
<i>PB3 – Internal Diagnostics</i> .....	28
PB1 – Relay Module Diagnostics .....	28
PB2 – Toggle Backup Mode.....	28
PB3 – RS-232 Diagnostic.....	28
PB4 – Keyboard Diagnostic .....	29
<i>PB4 – Tone/Alarm Diagnostics</i> .....	29
PB1 – Sidetone Level Adjust Mode.....	29
PB2 – DTMF Level Adjust Mode .....	30
PB3 –AMI Message Diagnostics .....	30
<i>Time Setting</i> .....	30
<b>THEORY OF OPERATION</b> .....	<b>31</b>
GENERAL DESK SET OVERVIEW .....	31
RECEIVE AUDIO .....	31
SPEAKER AUDIO.....	31
TRANSMIT AUDIO .....	32
MICROPHONE AUDIO.....	32
RELAY CONTROL MODULE .....	32
RESET CIRCUIT .....	32
<b>CARD SUITE PROGRAMMING SOFTWARE</b> .....	<b>33</b>
GENERAL DESCRIPTION .....	33
CONNECTION .....	33
INSTALLATION .....	33
READING THE UNIT .....	33
CARD SUITE PROGRAMMING .....	34
<i>Editing Screen</i> .....	34
PROGRAMMING THE ACC2500 .....	34
<i>Zone Field Name</i> .....	34
<i>Alarm Field Name</i> .....	34
<i>DTMF Setup</i> .....	34
Page PTT Pretime.....	34
Zone Address Length.....	35
Preamble Digits .....	35
Zone Activation Duration.....	35
DTMF Digit Time .....	35
Restrict Entry of Manual Zones.....	35
Restrict DTMF Over Dial .....	35
<i>Preprogrammed Zone/Alarm Aliases</i> .....	35
Preprogrammed Zone / No Alarm.....	35
Preprogrammed Zone with Alarm .....	36
<i>Programmable Buttons</i> .....	36
<i>Other Necessary Programming Settings</i> .....	36
<b>TROUBLESHOOTING</b> .....	<b>37</b>
TROUBLESHOOTING THE ACC2500 DESK SET .....	37
FUSE REPLACEMENT.....	38
<b>CIRCUIT BOARDS</b> .....	<b>39</b>
<b>SCHEMATICS</b> .....	<b>43</b>
<b>NOTES</b> .....	<b>52</b>

## Scope of Manual

This manual offers descriptive data and service information for the Model ACC2500 Audio Control Center. Service diagrams and printed circuit board details are a part of this service manual.

## Nomenclature

The model number, located on the nameplate on the bottom, specifically identifies GAI-Tronics equipment. If additional options are ordered, the option is identified on the circuit board.

## Ordering Replacement Parts

When ordering replacement parts or requesting equipment information, please include the complete identification number. This applies to all components, kits, and chassis. If the component part number is not known, the order should include the number of the chassis or kit of which it is a part and sufficient description of the desired component to identify it. Order parts from:

### **Customer Service**

GAI-Tronics Corporation

400 E. Wyomissing Ave.

Mohnton, PA 19540

US: 800-492-1212

Outside US: 610-777-1374

## Service and Repair

Inoperative or malfunctioning equipment should be returned to the factory for repair. Please call **1-800-492-1212** to obtain a Return Authorization number, published repair prices, and shipping instructions. A Return Authorization number can also be obtained by visiting our website at [www.gai-tronics.com](http://www.gai-tronics.com).

**NOTE:** A purchase order or credit card number is required prior to processing non-warranty repairs.

## FCC Interference Warning

The FCC requires that manuals pertaining to Class A and Class B computing devices must contain warnings about possible interference with local residential radio and TV reception. This warning reads as follows:

**NOTE:** This equipment has been tested and found to comply with the limits for a Class A digital device, pursuant to Part 15 of the FCC Rules. These limits are designed to provide reasonable protection against harmful interference when the equipment is operated in a commercial environment. This equipment generates, uses, and can radiate radio frequency energy and, if not installed and used in accordance with the instruction manual, may cause harmful interference to radio communications. Operation of this equipment in a residential area is likely to cause harmful interference in which case the user will be required to correct the interference at his own expense.

## Safe Handling of CMOS Integrated Circuit Devices

Many of the integrated circuit devices used in communications equipment are of the Complementary Metal Oxide Semiconductor (CMOS) type. Because of their high open circuit impedance, CMOS integrated circuits are vulnerable to damage from static charges. Care must be taken handling, shipping, and servicing them and the assemblies in which they are used.

Even though protection devices are provided in CMOS integrated circuit inputs, the protection is effective only against over-voltage in the hundreds of volts range such as is encountered in an operating system. In a system, circuit elements distribute static charges and load the CMOS circuits, decreasing the chance of damage. However, CMOS circuits can be damaged by improper handling of the modules, even in a system.

To avoid damage to circuits, observe the following handling, shipping, and servicing precautions:

1. Prior to and while servicing a circuit module, particularly after moving within the service area, momentarily touch both hands to a bare metal, earth-grounded surface. This will discharge any static charge that may have accumulated on the person doing the servicing.

**NOTE:** Wearing a conductive wrist strap will minimize static build-up during servicing.

2. Whenever possible, avoid touching any electrically conductive parts of the circuit module with your hands.
3. Power down the unit before installing or removing the circuit module.
4. When servicing a circuit module, avoid carpeted areas, dry environments, and certain types of clothing (silk, nylon, etc.) because they contribute to static build-up. Similarly, disconnect the test probe prior to removing the ground lead.
5. All electrically powered test equipment should be grounded. Apply the ground lead from the test equipment to the circuit module before connecting the test probe.
6. If a circuit module is removed from the system, it is desirable to lay it on a conductive surface (such as a sheet of aluminum foil) that is connected to ground through 100k of resistance.
7. When soldering, be sure the soldering iron is grounded and has a grounded tip.
8. Prior to connecting jumpers, replacing circuit components, or touching CMOS pins (if this becomes necessary in the replacement of an integrated circuit device), be sure to discharge any static build-up as described in procedure 1. Since voltage differences can exist across the human body, it is recommended that only one hand be used if it is necessary to touch pins on the CMOS device and associated board wiring.
9. When replacing a CMOS integrated circuit device, leave the device in its conductive rail container or conductive foam until it is to be inserted into the printed circuit module.
10. All low impedance test equipment (such as pulse generators, etc.) should be connected to CMOS device inputs after power is applied to the CMOS circuitry. Similarly, such low impedance equipment should be disconnected before power is turned off.
11. Replacement modules shipped separately from the factory will be packaged in a conductive material. Any modules being transported from one area to another should be wrapped in a similar material (aluminum foil may be used). **Never use non-conductive material** for packaging these modules.

---

Features and Benefits

Feature	Benefit
LCD display	Allows user-friendly interface; displays zone and alarm, status and diagnostic information.
Programmable buttons	Four buttons provide up to eight user-defined actions, i.e., preprogrammed zone and alarm selection, button remapping, output control, etc.
DTMF Control for Model 133x2 Series Amplified Addressable Speakers and GAI-Tronics SBA and SBM Stanchion assemblies.	Generates the necessary control tones to address the GAI-Tronics Amplified Addressable Speaker series and Stanchion Broadcast products.
Hot-Standby Control	Additional units can be connected for hot standby control in case of primary failure. (Requires relay control option to be installed.)
External Event Notification	LCD indicates external Audio Messenger Interface (AMI) event activity such as contact closure or phone call.
Direct AMI Audio Monitoring	User can hear all audio being generated by the AMI whether originated from the ACC2500 or external event such as a timed event or telephone broadcast.
Live Broadcast	Supports live broadcast with zone selection
Front-mounted controls and adjustments	Includes mute/unmute and local speaker on/off.
Preannounce tone	When programmed in the Audio Messenger Interface (AMI), a preannounce tone will be generated prior to live broadcast from the unit speaker and all addressed speakers/stanchions.
Built-in internal mic and speaker	Allows for single push-button communication.
Programmable inputs and outputs	Inputs and outputs can be configured for a variety of selections. (Requires relay control option to be installed.)

## Introduction to the ACC2500 Audio Control Center

The ACC2500 Audio Control Center works in conjunction with the GAI-Tronics Audio Messenger Interface (AMI), Model 133x2 Addressable Amplified Speakers, and the GAI-Tronics Stanchion Broadcast products to provide a complete wide-area broadcast and alert system. The unit allows addressing of individual, zone or all addressable units in the system. Using the Audio Messenger Interface, live voice, preprogrammed voice/tone messages as well as telephone dial-up live broadcasts can be made over the system.

Each of the four programmable buttons can be configured for up to eight preset zone selection or preset zone/alarm selection. In addition, the four **optional** inputs and three outputs can be programmed for various uses. With optional relays, outputs can be configured for On-Air Light, General Purpose Control, and On/Off. Inputs can be configured for Button Remap, Output Link, and Link to a preprogrammed zone and alarm configuration.

The ACC2500 uses DTMF control for zone selection of the Addressable Amplified Speakers or Stanchion Broadcast products. The unit allows direct entry of zones via the numeric keypad or selection of zones using a preprogrammed alias (programmed using the CARD Suite software application.)

In addition, the unit allows direct entry of preprogrammed alarm messages/tones using the numeric keypad or selection using the names of each message/alarm as programmed using the AMI ACT tool provided with the Audio Messenger Interface. Upon power-up, the ACC2500 will verify the contents of the AMI messages and retrieve them for use as necessary.

## System Component References

The following represents a few common system component references.

ACC2500 Audio Control Center – The ACC2500 is a desktop unit complete with push-to-talk handset, integral speaker and microphone, LCD display, DTMF keypad, and various control buttons. This unit communicates directly with the AMI via RS-232.

Audio Messenger Interface (AMI) – The AMI provides programmed speech message and alarm tone outputs via activation from the ACC2500. Additionally, the AMI provides dial-up telephone access to the system.

Stanchion Broadcast Products – The 234SBA Stanchion Broadcast Assembly and 234SBM Stanchion Broadcast Module receive the audio signal generated by the AMI and/or ACC2500. The units' integral speakers broadcast the received signal.

Addressable Amplified Speaker – The Addressable Amplified Speaker series provides discrete speaker broadcasts of the AMI or ACC2500 audio signal.



## Desk Set Button Panel

**TRANSMIT Button and LED** The red TRANSMIT button is used to place the unit in the broadcast mode and to initiate voice and alarm transmissions. The TRANSMIT LED, located to the left of the button, illuminates steadily when transmitting voice and flashes when the AMI is actively generating a message/alarm or in a telephone voice call.

**DEACT Button and LED** The DEACT button is used to immediately deactivate all active speakers or broadcast assemblies and cease any activity currently on the AMI.

**VOLUME Buttons** The units contain two buttons labeled VOLUME imprinted with up and down arrows. They are used to increase and decrease the local speaker volume and microphone levels. They are also used for special applications.

**CTL** CTL is used in conjunction with other buttons to provide secondary key functions.

**TIME** The TIME button briefly displays the current time. This time is retrieved from the AMI and can be useful to monitor for timed events automatically generated by the AMI.

**Keypad Buttons** The numeric keypad is used for the selection of a desired zone and alarms. See the Operations section of this manual for further information.

**STOP/CLR Button** The STOP/CLR button serves two purposes. While an alarm is being generated pressing the STOP/CLR button will stop the generation of the alarm and keep the addressed speakers/broadcast assemblies active for their time-out duration. When selecting a zone or alarm, pressing the STOP/CLR button will, if allowed via CARD Suite, permit manual entry of the zone or alarm.

**ZONE UP and DOWN Buttons:** The ZONE UP and DOWN buttons allow selection of a particular address or zone using preprogrammed aliases. If no aliases have been programmed using the CARD Suite application, these buttons are not used.

**ALARM ON/OFF Button** The ALARM ON/OFF button is used to turn alarm generation on or off. When off, pressing the TRANSMIT button will activate the selected zone and allow live voice broadcast while holding the TRANSMIT button. When on, the alarm will be displayed in the second line of the LCD display. Pressing the TRANSMIT button will initiate the alarm. While the alarm is active, pressing the TRANSMIT button will allow voice-over live broadcast while keeping the alarm playing at a reduced or muted level.

**ALARM UP and DOWN Buttons** The ALARM UP/DOWN buttons allow selection of the messages as programmed in the AMI via the ACT tool program.

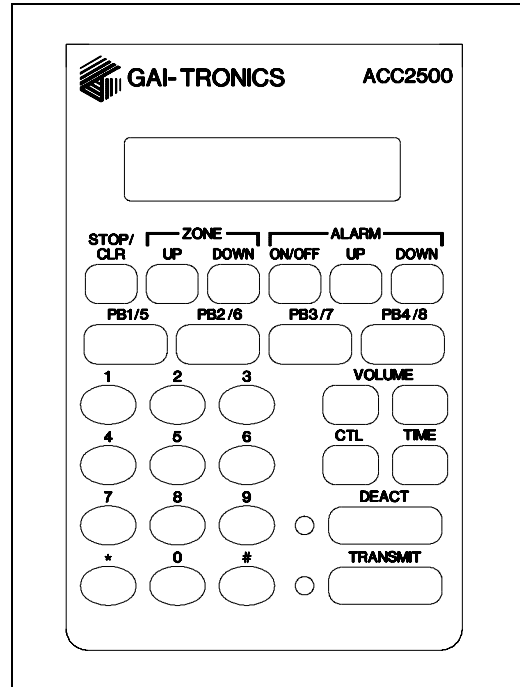

ACC2500 Front Panel

**LCD Display:** Each of the desk sets includes a backlit 2×16 character LCD display for operator information.

**Programmable Buttons:** The PB1, PB2, PB3, and PB4 programmable buttons can each be configured to perform two separate functions: one directly and the other in conjunction with the CTL button. Depending on its configuration, the selected button illuminates when it is pressed.

## Internal Microphone and Speaker

This microphone is intended for use in low noise environments. The handset must be on-hook in order to use the microphone. The internal microphone and speaker are provided to allow one-button communication.

## Handset

Each ACC2500 is equipped with a handset with a coil cord used for receiving and transmitting calls. The handset includes a push-to-talk (PTT) pressbar.

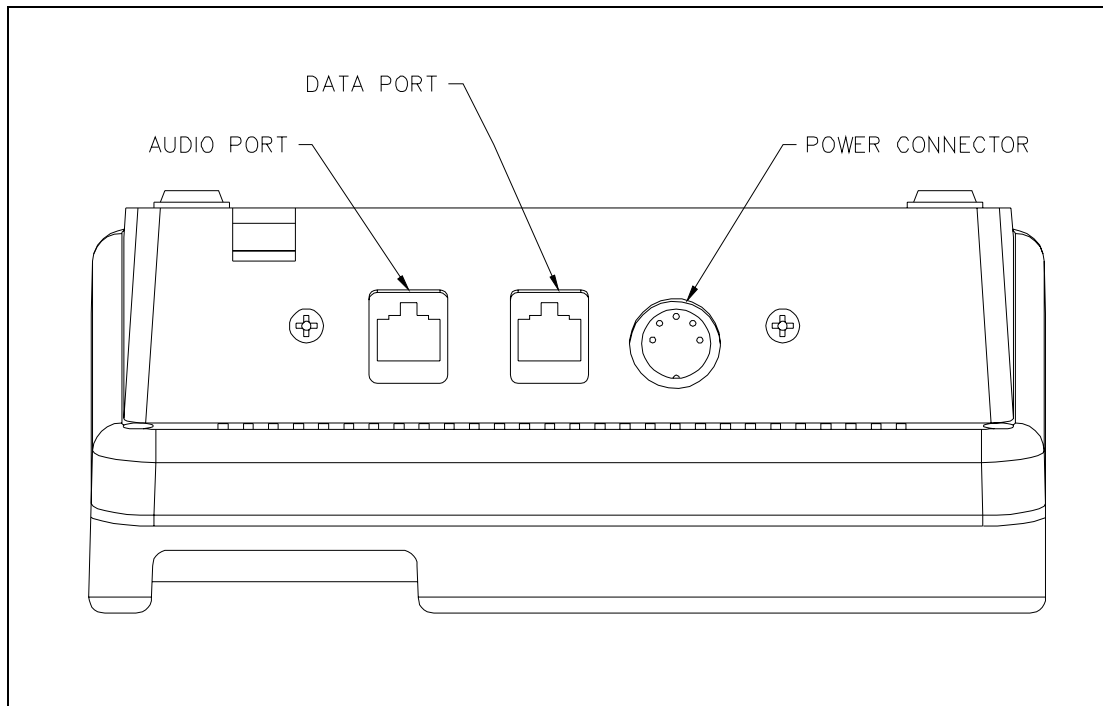

Rear View of ACC2500

## Connectors

### Power Connector

The ACC2500 is powered by a listed ac wall transformer supplying nominal 12 V dc. The operating range is 10.5 to 15 V dc. The 5-pin power connector diagram and pinout are shown below:

Pin	Function
1	-IN
2	Battery backup +IN
3	+IN
4	-IN
5	+IN

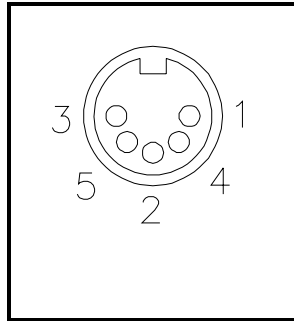

### AMI Connections

The rear of the ACC2500 contains two modular ports used to connect to the front control port of the AMI.

The 6-pin line connector is the transmit and receive audio connection to the AMI.

Pin	Function
1	No connection
2	RX +IN
3	TX +OUT
4	TX -OUT
5	RX -IN
6	No connection

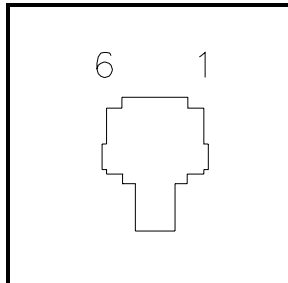

The 8-pin modular connector is the RS-232 data control port.

Pin	Function
1	No connection
2	RS-232 TX OUT
3	No connection
4	GND
5	No connection
6	No connection
7	RS-232 RX IN
8	No connection

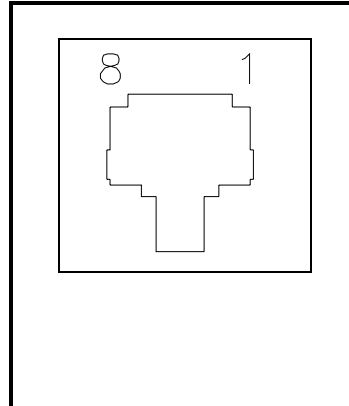

**NOTE: It is important that those pins labeled "No connection" be left un-terminated. Connection of these pins may damage the ACC2500 or AMI and may not be covered under warranty.**

To facilitate the connection of these two ports to the AMI, the 69612-xxx (purchased separately) contains three modular connectors and two cables. The two cables included combine the 8-pin and 6-pin ports as necessary to allow connection to the front AMI control port using a standard category-5 networking cable. This CAT-5 cable must be provided by the installer and must not exceed 45 feet in length.

## Accessories, and Options and Kits

Description	Part No.
CARD Suite Software on CD	XAC1000A
Programming Cable	XAC0004A
Relay Control Field Install Kit	XRC0001A*
Mounting Kit for Option Boards	XAC0100A
Power Supply, 120 V ac 60 Hz	3308-00750-00
Power Supply, 110/220 V ac 50/60 Hz	3308-00750-10
Desk Microphone**	XDM002A
Gooseneck Microphone**	XGM002A
Amplified Headset**	XHS003B
Coiled Cord (required for XHS003B)	XCC004B
Footswitch**	XFS002A
Audio Accessory Box	XAAB002A

\*Requires XAC0100A (1 per unit)

\*\*Requires XAAB002A Audio Accessory Box (1 per unit)

## Performance Specifications

Color .....	Black
Physical size .....	7.6 W × 8.9 L × 4.7 H inches
Weight .....	2.4 lbs.
Temperature range .....	-35° C to +70° C
Humidity .....	95% at 50° C (non-condensing)
Tx/Rx impedance .....	600 ohms nominal
Power input .....	10.5 to 16 V dc; 500 mA maximum from supplied ac adapter
Safety .....	Class III SELV powered equipment. Powered by UL-listed (E104603) and CSA-certified (LR67888) Class 2 ac adapter.
Emissions: .....	USA: FCC Part 15, Sub. B- Verification. Canada: ICES – 003
Line interface .....	FCC Part 68 Exempt (Category II Tariff #260 service for private/leased line applications) Canada: IC CS03-8 Range -14 to +12 dB into 560 ohms
Frequency response .....	±3 dB, 300 to 3000 Hz (except notch filter)
Hum and noise .....	Less than -45 dB below rated outputs
Audio output to speakers .....	1 watt minimum with level in compression range
Audio distortion .....	Less than 3% THD

The ACC2500 provides system control of a GAI-Tronics wide-area broadcast system consisting of an Audio Messenger Interface (AMI), amplified addressable speakers and/or stanchion broadcast products. It allows selection of individual units or zones and selection of preprogrammed speech/tone alarms.

Audio that is output from the AMI is directly routed to the integral speaker or handset to allow direct monitoring of the AMI audio by the ACC2500 operator.

## Display

The ACC2500 has a backlit 2×16-character super-twist LCD display to provide valuable operator information. This information allows the operator to determine the status of the unit. The following describes the display at various states:

### **At power up:**

- Initially, line 1 shows: CHECKING PARAMS, and line 2 shows: PLEASE WAIT.
- After 3 to 5 seconds, line 1 shows ACC2500, and line 2 shows the firmware version.

### **During normal operation,**

Line 1 shows the currently selected zone, i.e. Zone 12

Line 2 shows:

- Speaker/handset audio level during a change of level
- Alarm selection when turned on or active
- AMI activity during internal and external events
- The current time when the TIME button is pressed
- Operator instructions during broadcast of live voice

**During installation,** the display shows various diagnostic information.

## Idle Mode

When power is applied, the ACC2500 is in the receive or idle mode, allowing any AMI audio to be heard through the speaker or handset. It is always in this mode unless the unit is transmitting.

The ACC2500 contains an internal or local speaker and a handset that operate as follows:

- When the handset is in the cradle, or on-hook, audio is heard on the internal speaker. In some operational modes, this can be changed, i.e., muting the speaker by pressing CTL + VOL Down.
- When the handset is off-hook, audio is routed to the handset receiver. By using the front panel buttons, you may optionally select to hear audio through the local speaker in addition to the handset.

## Zone Selection

The system can have many zones available to the operator each including one to many speakers or broadcast assemblies. In order to select the proper zone for a broadcast of any type, the operator must first select the desired zone. This zone is displayed on the first line of the LCD display.

Note that during installation and programming, the zone label can be changed to a desired display using the CARD Suite application. By default, if nothing is programmed, the word "Zone" will be displayed on the first line of the display. This could be changed to "Group," "Area," "Z" or any alphanumeric description of up to eight characters.

After initial power-up, the display will be as shown below where the address of all units and zones is programmed to be 3 digits in length.

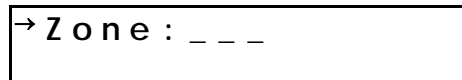

→ Zone : \_ \_ \_

The "→" in the first location of the first line indicates that the zone selection is active. To manually select a zone using the numeric key, enter the desired address or zone. To select zone 123, press "1," "2," followed by "3." As the digits are entered, the first digit will be display in the third blank and moved to the left as subsequent digits are entered. If more than the allowed number of digits is entered, the zone entry will be cleared and the last digit will become the first digit of the new address. After entry of the zone, the display will appear as shown below:

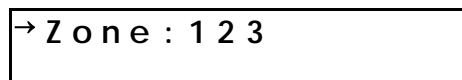

→ Zone : 1 2 3



If zone aliases have been programmed using the CARD Suite application, the operator may choose a zone using a name instead of a direct number. For example, zone 123 can be programmed as “Zone 1,” zone 234 can be “Zone 2,” zone 345 can be “Zone 3,” zone 456 can be “Zone 4” and all zones can be “Zone All.” To select a particular zone, the operator can use the ZONE Up/Down buttons to scroll to the desired zone such as “Zone 3” as shown below:

→ Zone : Zone 3

If the alias has a pre-configured alarm associated with it, the alarm will be displayed on the second line of the display. The operator may not override or turn off this pre-configured alarm and attempting to do so will display an error message along with an error tone.

If the operator wishes to revert to manual entry, pressing the STOP/CLR button will switch back to manual entry and will display the last manually entered zone. If the unit is programmed to restrict manual entry of the zone addressed, pressing the STOP/CLR button will result in an error message and tone. While in manual entry mode, pressing STOP/CLR a second time clears the zone entry.

### Initiating Live Voice Broadcasts without an Alarm

After selecting the desired zone, the operator may initiate a live broadcast immediately by pressing and holding any PTT source such as the main TRANSMIT button, handset PTT or PTT of a connected accessory.

Upon pressing and holding PTT, if the selected zone is not active (more on this below) the unit will generate the necessary DTMF digits to activate the desired zone. During the DTMF generation, the second line of the display will be:

Zone : Zone 3  
\* \* \* WAIT \* \* \*

After generation of the DTMF sequence, the AMI, if programmed to do so, will generate a preannouncement tone that is broadcast over the unit speaker and the selected zone. The operator will hear the preannouncement tone and will be instructed to wait during the generation of the tone. Upon completion of the preannouncement tone, the display will change to:

ACTIVE : Zone 3  
\* \* \* TALK NOW \* \* \*

“ACTIVE” will be flashing indicating that the selected zone has been activated and is within its time-out duration. As long as the PTT source is held, the display will remain in this state. The operator may speak whenever the display indicates \*\*\*TALK NOW\*\*\*.

To cease voice broadcast the operator must release the PTT source. Upon doing so, the display will change to:

ACTIVE : Zone 3

Where “ACTIVE” will continue to flash for a programmed duration. This duration is determined by and should be set to what the time-out time of the units in the particular zone are programmed to. For example, if the units of a zone are set to deactivate after 5 seconds of inactivity, this time should be set for 5 seconds.

While “ACTIVE” is displayed and flashing, the operator may initiate another broadcast and the unit will not regenerate the DTMF sequence needed to activate the units in the zone. When the word “ACTIVE” is not displayed and flashing, the unit will generate the necessary DTMF sequence to activate the selected zone each time a broadcast is initiated.

#### Handset Transmit

Use of the handset is recommended when the desk set is located in noisy surroundings. Press the handset PTT bar or TRANSMIT button and speak into the handset microphone to transmit when the handset is off-hook.

#### Transmit from Internal (Local) Microphone

Use the internal microphone only in low noise environments. The handset must be on-hook for the local microphone to operate. Press the TRANSMIT button and speak in the direction of the integral microphone. For the best transmit audio quality, maintain a distance of about 18 inches from the microphone.

#### Transmit from Desk Microphone or Footswitch

All models can be keyed to transmit with an external desk microphone when used with the optional Model XAAB002A Audio Accessory Box. Use of the GAI-Tronics Model XHS002A Desk Mic, or compatible microphone, is recommended. Refer to the XAAB002A documentation for connection and installation of this option.

## Alarm Selection

In addition to live voice broadcasts, the ACC2500 allows selection of programmed alarm/speech messages to be broadcast to particular zone. If the displayed alias has a preconfigured alarm associated with it, the operator may not change it or turn it off. To select an alarm, press the ALARM ON/OFF, ALARM UP or DOWN buttons until the second line of the display is as shown below:

```
Zone : Zone 3
→Alarm : _ _ _
```

The “→” in the first location of the second line indicates that the alarm selection is active. To manually select an alarm using the numeric key, enter the desired alarm number as stored in the AMI. To select alarm 12, press “1” followed by “2.” As the digits are entered, the first digit will be display in the third blank and moved to the left as subsequent digits are entered. If more than the allowed number of digits is entered, the alarm entry will be cleared and the last digit will become the first digit of the new alarm. After entry of the alarm, the display will be as shown below:

```
Zone : Zone 3
→Alarm : _ 1 2
```

The alarm aliases differ from the zone aliases in that they are retrieved from the AMI as necessary and programming of these aliases is done with the ACT Tool. To select a particular alarm using the AMI aliases, press the ALARM Up/Down buttons to scroll to the desired alarm name.

```
Zone : Zone 3
→Alarm : Lock Down
```

Note that, like zone selection, the name of the alarm field can be changed via CARD Suite to any desired alphanumeric name of up to eight characters. By default, the field will be named “Alm:” A consideration here is that the AMI message names are up to 32 characters in length and using the field name of “Alarm” uses valuable display space allowing only the first 9 characters of the AMI name to be displayed. If more characters are desired, the field name can be changed to “A,” which will allow up to 14 characters of the AMI name to be displayed.

If the operator wishes to revert to manual entry, pressing the STOP/CLR button will clear the alarm entry.

## Initiating Alarm Broadcasts without Voice

After the desired zone and alarm have been selected, the operator may begin broadcasting the alarm by pressing and releasing any PTT source such as the main TRANSMIT button, handset PTT or PTT of a connected accessory.

Upon pressing PTT, if the selected zone is not active, the unit will generate the necessary DTMF digits to activate the desired zone. During the DTMF generation, the second line of the display will be:

```
Zone : Zone 3
*** WAIT ***
```

After generation of the DTMF sequence, the AMI will begin generation of the selected alarm that will be broadcast over the unit's speaker and the selected zone. The display will be as shown below:

```
ACTIVE : Zone 3
Alarm : Lock Down
```

“ACTIVE,” “Alarm” and the alarm name will be flashing indicating that the selected zone has been activated, is within its time-out duration, and the selected alarm is being broadcast. In addition, the TRANSMIT LED will flash. As long as the alarm is being broadcast the display will remain in this state. Depending on the programming of the particular alarm selected in the AMI, the alarm may broadcast one or more times or repeat indefinitely.

If the alarm is programmed to broadcast for a predetermined number of times, upon completion of the last broadcast, the alarm will cease playback and the flashing of “Alarm,” and the alarm name and the TRANSMIT LED will cease. After the selected units time out due to inactivity, the display will return to the alarm edit mode as shown below:

```
Zone : Zone 3
→ Alarm : Lock Down
```

## Stopping the Broadcast of an Alarm

Once an alarm broadcast has been initiated, it may be desirable to stop playback or select another alarm instead. This can be done in many ways.

To stop the alarm being broadcast, press any of the following buttons: STOP/CLR, ZONE UP or DOWN, ALARM ON/OFF, ALARM UP or DOWN or DEACT. Any of these buttons will end broadcast of the current alarm and return to either zone select or alarm select mode depending on which button is pressed. Pressing ZONE UP or DOWN will end the broadcast and return to zone selection. Pressing the ALARM ON/OFF or ALARM UP or DOWN will end the broadcast and return to alarm selection. Pressing STOP/CLR or DEACT will end the broadcast and return to the previously selected mode.

### STOP/CLR vs. DEACT

While the STOP/CLR button and DEACT button both will end an alarm broadcast, their purpose and behavior are different.

Using the STOP/CLR button to cease an alarm broadcast simply does that. It leaves the selected field units active for the duration of the inactivity time. This is similar to the behavior of pressing the ZONE or ALARM buttons during alarm broadcast. Leaving the selected field units active will allow the selection of a new alarm without requiring the regeneration of the DTMF sequence to activate the currently active units. Selecting a different zone will keep the currently active zone and add the newly selected zone to the active field units. Note that the DTMF sequence of the newly activated zone will be broadcast over the currently active field units.

Using the DEACT ends an alarm broadcast and generates a DTMF stop sequence to all speakers causing any active speaker to immediately go inactive. This is useful if the field units are configured to stay active during the presence of audio: no hard contact closure. In this case, if the operator wishes to generate an alarm to a different zone and deactivate the current zone without waiting the inactivity time, pressing the DEACT button will stop all field units from broadcasting. Upon pressing the DEACT button, "DEACTIVATING ALL" will be displayed on the second line and a DTMF stop sequence will be generated.

In addition to the above-mentioned differences, the DEACT button can be used at any time to deactivate any field units. If the operator must override any current activity, pressing the DEACT button first will ensure that all speakers are immediately deactivated.

## Initiating Live Voice Broadcast during an Alarm Broadcast

When the unit is broadcasting an alarm, it may be necessary for the operator to speak over the alarm to provide additional details related to the current situation. To do this, it is advised that the internal microphone not be used since during the voice broadcast, the operator will continue to hear the alarm audio while speaking. If using the internal microphone during an alarm broadcast, the possibility of interference or echo can occur.

To initiate a live broadcast during an alarm, the operator simply presses and holds a PTT source and speaks into the appropriate microphone. Upon pressing the PTT source the display will show:

```
Zone : Zone 3
*** WAIT ***
```

The preannounce tone will be broadcast and heard by the operator. When the preannounce tone is complete, the display will change as shown below:

```
ACTIVE : Zone 3
*** TALK NOW ***
```

The operator may now speak. Depending on the programming of the AMI, the alarm broadcast will be reduced in level or muted completely.

## Overdialing DTMF

The ACC2500 allows the operator to generate DTMF sequences while field units are active. This can be used to remotely control the field units' volume or to add in additional field units by specifically dialing the address of the desired field units. The feature is only available while "ACTIVE" is flashing on the first line of the display and the unit has not been restricted from DTMF overdial.

To remotely control the volume of an individual field unit, it is recommended that the address of the unit be selected as the zone, and no alarm selected. After activating the specific unit as described earlier, the operator can initiate the remote volume control by pressing the "\*" button on the numeric keypad. Upon pressing the button, the field unit will enter volume control mode. Since the field unit may not be audible from the operator, a second person near the field unit may be necessary to relay whether the unit's volume should be increased or decreased using additional presses of the "\*" and "#" buttons respectively.

To add in additional zones or field units to the currently active zones or field units, the specific address of the desired unit or zone must be known. While "ACTIVE" is still flashing on the display, the operator simply enters the manual address of the zone or field unit directly followed by a single press of the "#" key. Upon pressing the "#" key, the newly added zone or units will now be active.

To manually disable all field units, the operator can, while "ACTIVE" is flashing, press the "#" twice to provide the proper stop sequence.

## Programmable Buttons

The four programmable buttons with LED indicators are used to custom configure up to eight user functions. The PB1 through PB4 buttons are accessed directly, while the PB5 to PB8 buttons are accessed using the CTL key while depressing one of the PB1 through PB4 buttons. When shipped from the factory, the programmable buttons are disabled. Refer to the CARD Suite Help file for programming information.

When a programmable button is configured with a preprogrammed alias, upon pressing the button, the zone will be activated and the displayed alarm, if turned on, will be broadcast. If the alias associated with the programmable button has a pre-configured alarm, the displayed alarm will be overridden and the associated pre-configured alarm will be played instead.

## VOLUME Up and VOLUME Down Buttons

Press the VOLUME Up or Down buttons to adjust the local speaker volume if the handset is on-hook. The handset speaker volume is adjusted if the handset is off-hook.

The display shows the new setting for two seconds after a volume change. The internal speaker and handset each have individual settings. When the handset is off-hook, the following message is displayed:

HANDSET VOL: X (handset off-hook)                      SPEAKER VOL: X (handset on-hook)

The VOLUME Up and VOLUME Down buttons also adjust the sensitivity of the microphone that is currently in use. Refer to the Microphone Sensitivity Adjustments section on page 24 of this manual for more information.

Pressing the CTL + VOLUME Up buttons activates the internal speaker when the handset is off-hook. This can be used if others must hear the audio when off hook. When the handset is returned to the cradle, this setting is reset so that if the handset is again removed from the cradle, the internal speaker is not active.

Pressing the CTL + VOLUME Down buttons mutes the internal speaker indefinitely. Pressing VOLUME Up, VOLUME Down, CTL + VOLUME Up, or removing the handset from the cradle and returning it resets the setting.

## Combination Button Operation

Some button combinations are available to the operator to offer access to less frequently used functions of the unit. In order for these combinations to be initiated, the first button is pressed followed by the press of the second button while maintaining the first button press operating in a similar manner to the CTRL key on a computer keyboard. See the table below for available button combinations.

First + Second button	Description
CTL +VOL Down	Mutes the external speaker until an additional volume press or the handset is cycled off and on-hook.
CTL + VOL Up	Activates the speaker even when the handset is off-hook until the handset is placed back on-hook.
CTL + STOP/CLR	Prompts the user to force a reset of the attached AMI.
CTL + PB1-4	Provides access to the programmable button settings for PB5 through PB8.
TIME + VOL Up	Activates the microphone sensitivity feature.
TIME + VOL Down	Deactivates the microphone sensitivity feature.
TRANSMIT + VOL Up	If the microphone sensitivity feature is enabled, allows the operator to increase the sensitivity of the internal microphone when on-hook or the handset microphone when off-hook.
TRANSMIT + VOL Down	If the microphone sensitivity feature is enabled, allows the operator to decrease the sensitivity of the internal microphone when on-hook or the handset microphone when off-hook.
HS PTT* + VOL Up	If the microphone sensitivity feature is enabled, allows the operator to increase the sensitivity of the handset microphone when the handset PTT or optional audio accessory box PTT is active.
HS PTT* + VOL Down	If the microphone sensitivity feature is enabled, allows the operator to decrease the sensitivity of the handset microphone when the handset PTT or optional audio accessory box PTT is active.

\*When the optional Model XAAB002A Audio Accessory Box is used with the ACC2500, the handset port is used as a connection point for the audio accessory box. Therefore, any attached accessories will use the handset microphone sensitivity when the microphone's PTT is asserted.

## TIME Button

Use the TIME button to display the current time. This time is stored in the attached AMI. Upon pressing this button, the current time will be displayed for approximately 2 seconds on the second line of the display. This button is also used during boot to access the time set feature.



Planning the Installation

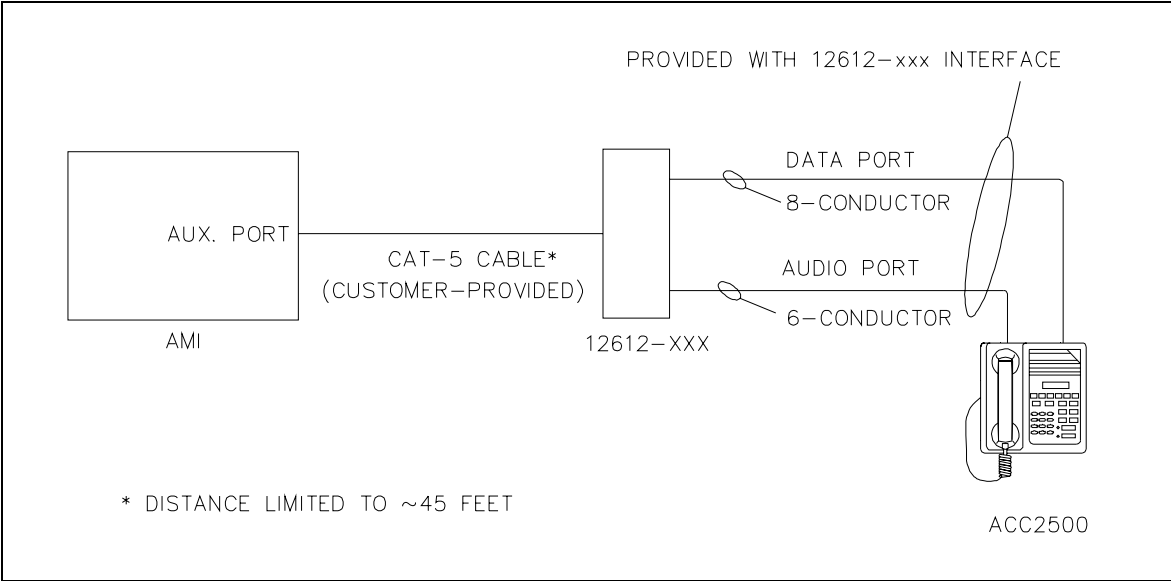

Typical ACC2500 Connection Diagram

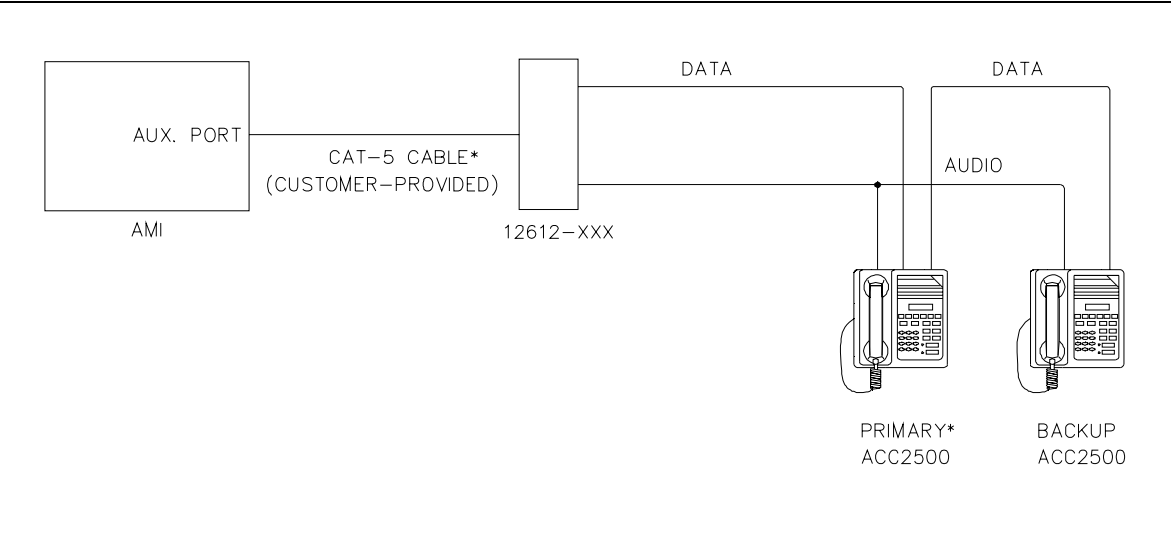

Hot Backup ACC2500 Connection Diagram

\*Requires the optional XRC0001A relay board and connection per Table 1 below.

Table 1. Backup Data Terminations using XRC0001A

Signal	Relay Board J701
Primary RXD	23
Primary TXD	20
Backup RXD	21
Backup TXD	18
Primary GND	24
Backup GND	24
12612 pin 2	19
12612 pin 7	22
12612 pin 8	24

### Mechanical Receipt Inspection

The desk sets are shipped in a cardboard container with inserts. Thoroughly inspect it as soon as possible after delivery. In-transit damage should be immediately reported to the transportation company.

### Mounting

The desk sets can be placed on a desk or mounted vertically on a wall. To wall mount the desk set, remove the four bottom screws from the base and then rotate the base 180°. Reinstall the four screws to the base and rotate the handset hook located on the front of the unit.

**NOTE:** Certain configurations restrict wall mounting.

### FCC Interference Warnings

The FCC requires that manuals pertaining to Class A and Class B computing devices contain warnings about possible interference with local and residential radio and TV reception. Please read these warnings and all safety information in the Foreword section of this manual.

### Electrostatic Discharge (ESD) Protection

The ACC2500 have ESD protection circuitry that provides a high degree of protection against ESD, and power and telephone line surges. The circuitry shunts the transient currents to earth ground through the ground terminal. One of the two screws located on the back of the desk set can be used as an earth ground terminal. See the rear view of the desk set for the ground screw terminal locations.

The ground terminal must be connected to a high quality earth ground point to obtain maximum protection. Ideally, the ground point should originate at a 1/2-inch copper rod driven at least six feet into the soil with a No. 16 AWG (or larger) copper wire run to the ground terminal taking the shortest path possible. Where this is not possible, ground to a nearby water pipe or best available ground.

### Cable Installation Safety Considerations

Wiring should conform to the Article 800 of the National Electrical Code. Use *listed* communication wiring and cabling for interconnection to other equipment that is suitable for the purpose. Cables should be *marked* as CM, CMP, CMR, or CMX as appropriate for the use.

Interconnecting data cables should be separated from electrical light or other Class I power cables by at least 2 inches. The exception is where Class I wiring or power circuits are run in a raceway or in metal-sheathed, metal-clad, or permanently separately from the conductors of the other circuitry by a continuous and firmly fixed nonconductor, such as porcelain tubes or flexible tubing in addition to the insulation on the wire. Interconnecting cables longer than 2 meters should be rated VW-1 or FT-1 or greater.

### Power Connection

Connect the ACC2500A to the listed ac wall transformer, provided with the unit, which supplies nominal 12 V dc. Optionally, the desk set can be powered by other dc sources. The operating range is 10.5 to 16 V dc. Refer to the power connection pinout on page 7 of the Connectors section of this manual.

### Audio and Data Connection

Connection to the AMI requires the use of the 69612-xxx unit and two cables, a 6-position and 8-position modular style cable assembly (provided with the 69612-xxx). An additional 8-conductor category 5 cable up to 45 feet in length must be supplied and connected from the 62612-xxx unit to the front data port on the AMI.

## Microphone Sensitivity Adjustments

After connections have been made, the ACC2500 must be configured for transmit and receive audio levels. These adjustments are made using the front panel buttons. The microphone sensitivity adjustment is used to compensate for different user voice levels and varied acoustical conditions. Refer to the following instructions to adjust the different microphones.

### Internal Microphone Sensitivity

1. Place the handset in the cradle.
2. While holding down TIME button, momentarily press VOLUME Up button ( $\Delta$ ) to enable microphone sensitivity adjustment. By default, this adjustment is disabled and must be enabled after each reset. The display will indicate the current microphone level on the display for approximately 2 seconds.
3. Press and hold TRANSMIT, speak into the internal microphone, and press VOLUME Up or VOLUME Down to increase sensitivity or decrease microphone sensitivity. **NOTE:** The display shows the relative TX level as a number between 1 and 5. To confirm the absolute level, measure the transmit level across the TX line pair using an ac millivolt meter or dBm meter.
4. After the adjustment has been made, press and hold the IC button, and momentarily press the VOLUME Down button. A single beep is heard to indicate the microphone sensitivity adjustment function has been disabled.

### Handset Microphone Sensitivity

1. With the handset off-hook, while holding down TIME button, momentarily press VOLUME Up button ( $\Delta$ ) to enable microphone sensitivity adjustment. By default, this adjustment is disabled and must be enabled after each reset. The display will indicate the current microphone level on the display for approximately 2 seconds.
2. To adjust the sensitivity level, press the handset PTT button, speak into the handset microphone, and press VOLUME Up or VOLUME Down to increase or decrease the sensitivity level.
3. After the adjustment has been made, press and hold the TIME button, and momentarily press the VOLUME Down button. A single beep is heard to indicate the microphone sensitivity adjustment function has been disabled.

**NOTE:** When an XAAB001A is used to connect other accessories, the handset microphone sensitivity adjustment is used for those devices.

## Level Adjustments and Diagnostics

### Programming Menu

The programming buttons, PB1 through PB4, are used to navigate the menu for specific installations and to perform diagnostics.

The diagram below illustrates which buttons to press to access the diagnostic menu features.

Press:      To select:

PB1	Line Output Adjust	Default: -10 dB
PB2	Line Input Sensitivity	Default: -9 dB
PB3	Internal Diagnostics:	
	Press:	To select:
	PB1	Relay Module Diag
	PB2	Toggle Back-up Mode
	PB3	RS-232 Diagnostic
	PB4	Keyboard Diagnostic
PB4	Tone/Alarm Diagnostics	
	Press:	To select:
	PB1	Sidetone Level Adjust (Default: 0 dBm)
	PB2	DTMF Level Adjust (Default: 0 dBm)
	PB3	AMI Message Diagnostic
TIME	Set Current Time and Date	

### Reloading Factory Defaults

Desk sets are shipped from the factory with default settings that meet most installation requirements. However, it is important to verify that these parameters are adjusted to meet your specific installation needs.

To reload factory defaults, enter the Main Diagnostic Selection as described below. After entering this mode, press CTL + VOLUME Up. The unit will automatically reset and show that the parameters are corrupt. Follow the instructions on the display. For some models, this may happen twice.

**NOTE:** If your unit has been programmed with CARD Suite software, reloading the factory defaults will reset all parameters that have been programmed.

### Main Diagnostics Selection

To enter the main programming mode:

1. Remove power from the desk set.
2. Reapply power and wait for the PB1 through PB4 LEDs to illuminate. (The display will indicate “checking parameters - please wait.”) Press either PB1, PB2, PB3, or PB4 to enter diagnostics.
3. The display will then indicate that the Main Diagnostics mode has been entered, and buttons PB1-PB4 can now be pressed. PB1 through PB4 are used to select different parameter changes from the default settings.

### PB1 – Line Output Adjust

An ac voltmeter or Sinadder meter should be connected across the line to achieve the proper level setting. Ensure that the line is terminated with a 600-ohm load.

After entering the Main Diagnostic selection mode, press the PB1 button. The display will indicate the current setting, which is set at the factory at -10 dBm. The range for this setting is variable from off to +12 dBm. See the Line Output Adjustment table for approximate settings. The desk set buttons are used as follows in the Line Output Adjust mode:

Button	Line Output Level Adjustment Mode Function:
VOLUME Up	Increases the output level, verifying the proper level with the meter connected to the line.
CTL + VOLUME Up	Increases the output level by 10.
VOLUME Down	Decreases the output level, verifying the proper level with the meter connected to the line.
CTL + VOLUME Down	Decreases the output level by 10.
TRANSMIT	Saves the current setting and exits back to the main selection mode.
DEACT	Restores the previously programmed setting.
TIME	Exits the line output adjustment mode without saving the selection, but maintains the current setting until the power to the unit is cycled. This is useful for experimenting with different settings.

Program the desk set's line level to achieve adequate deflection of the VU meter of the AMI. Refer to the following table for these settings:

Line Output Adjustment Table

Setting	Line Level (600-ohm)
03	-10 dBm
07	-5 dBm
0C	0 dBm
18	+5 dBm
2D	+10 dBm

### PB2 - Line-In Sensitivity

After entering the main programming selection mode, press the PB2 button to allow adjustment of the line-in sensitivity. This adjustment allows the desk set to compensate for a range of 0 to 15 dB of line loss in 3 dB increments. The compensation is considered a pre-gain to the line-in circuitry of the desk set.

For example, if the audio from the AMI is 0 dBm, and the audio line has 10 dB of line loss, the line input sensitivity should be set to level 4 (-9 dBm) to accommodate the 10 dB of incurred line loss.

After pressing the PB2, the display indicates the current line-in setting. The buttons function as follows:

Button	Line-in Sensitivity Mode Function:
VOLUME Up	Decreases the line-in sensitivity or reduces the pre-gain for the line input.
VOLUME Down	Increases the line-in sensitivity or increases the pre-gain for the line input line.
TRANSMIT	Saves the current setting and exits back to the main selection mode.
DEACT	Restores the previously programmed setting.
TIME	Exits the line-in sensitivity mode without saving the selection, but maintains the current setting until the power to the unit is cycled. This is useful for experimenting with different settings.

### PB3 – Internal Diagnostics

There are four internal diagnostic modes available; dc or MLS module, depending on the board installed (PB1), relay module (PB2), RS-232 (PB3), and keyboard (PB4). After the internal diagnostic mode has been entered, they are accessed using the programming buttons as follows:

#### **PB1 – Relay Module Diagnostics**

This function is accessible via Main Diagnostics, then Internal Diagnostics (PB3). The Model XRC0001A Relay Option Kit must be installed in the unit under test. This function allows the relay I/O module to be exercised. The display indicates the status of:

- Inputs – IN
- Relay – OUT

By pressing any key (except TRANSMIT) starting at relay1 and progressing up to relay 4, the relays close and then open. The numeral 1 in the OUT position indicates the relay should be closed. LEDs on the relay I/O module also indicate the status of each relay.

To exercise the inputs, each input can be grounded. This is indicated by a numeral 1 in the IN position associated with the input. As each input is shorted to ground, the corresponding 1 in the IN position indicates a 0. To exit the relay module diagnostics, press TRANSMIT.

#### **PB2 – Toggle Backup Mode**

The ACC2500 supports hot-standby mode. In order to utilize this feature, the primary unit must include XRC0001A Relay Option and be connected properly.

When operating in primary mode, the unit engages relay 1 of the relay option board. This connects the RS-232 data from the AMI directly to the primary unit. When power to the primary unit is lost, the RS-232 connection will be made to the backup unit which will then assume full command of the AMI. Additional backup units can be cascaded in the same manner. When the primary ACC2500 recovers, it will take over command of the AMI and the backup units will enter backup mode.

Upon entry to this diagnostic, the unit will toggle primary/backup operation. The display will indicate the backup mode setting. Repeated selection of PB2 during internal diagnostics will, in-turn, enable and disable backup operation.

Pressing any key while the display is indicating the backup mode setting will return to internal diagnostics.

#### **PB3 – RS-232 Diagnostic**

This function is accessible via Main Diagnostics, then Internal Diagnostics (PB3), and exercises the RS-232 port TX and RX data. To run this test, disconnect anything connected to the programming connector on the back of the unit, and short pins 2 and 7 of the connector.

Once the short is completed, this unit sends data on the TX wire for receipt on the RX wire. If the same data is received on the RX wire, the unit continues to send data. If no data, or incorrect data is received, the unit stops sending data and displays failure.

Note that this diagnostic does not guarantee standard RS-232 levels. If the diagnostic functions, but the unit does not operate with a PC or printer, verify with an oscilloscope that the proper RS-232 levels are present. Press the TRANSMIT button to exit the RS-232 diagnostic.



**PB4 – Keyboard Diagnostic**

This function is accessible via Main Diagnostics, then Internal Diagnostic (PB3) and verifies that the keyboard is operating correctly. After entering the keyboard diagnostic mode, the display shows:

KEYBOARD TEST  
KEYCODE: xx

When any key is pressed (except TRANSMIT), the corresponding keycode is displayed. Refer to the keycode table that follows:

Button	Keycode (Hex)	Button	Keycode (Hex)
0–9	00 - 09	PB1 – PB4	30 - 33
*	0e	ALERT	45
#	0f	PAGE	44
TRANSMIT	No code (Will exit test.)	CLEAR	47
MONITOR	11	SELECT	46
TIME	13	DOWN	40
VOLUME Down	20	UP	41
VOLUME Up	21		

Press TRANSMIT to exit the keyboard diagnostic.

**PB4 – Tone/Alarm Diagnostics**

This function is accessible via Main Diagnostics mode select (PB4), and allows adjustment of the levels of sidetone (PB1) and the DTMF tones (PB2). The tone level adjust will display, then select PB1, PB2, or PB3.

- The sidetone level used for speaker tones can be adjusted to suit the user.
- The alert and page tone line levels can be adjusted relative to HLGT.

**PB1 – Sidetone Level Adjust Mode**

This mode allows the adjustment of the sidetone level to -15 dB in 3 dB steps:

Button(s)	Sidetone Level Adjust Mode Function:
VOLUME Up or VOLUME Down	Increases/decreases the sidetone line level. Each time the VOLUME Up or VOLUME Down button is pressed, a beep is generated and the LCD display shows the new setting.
TRANSMIT	Exits the sidetone level adjust mode and returns the unit to the tone level adjustment screen.

**PB2 – DTMF Level Adjust Mode**

This mode allows the DTMF line level to be adjusted to -15 dBm to 0dBm in 3 dB steps:

Button(s)	Alert Tone Level Adjust Mode Function:
VOLUME Up or VOLUME Down	Increases/decreases the DTMF line level. Each time the VOLUME Up or VOLUME Down button is pressed, a beep is generated and the LCD display shows the new setting.
TRANSMIT	Exits the DTMF level adjust mode and returns the unit to the tone level adjustment screen.

**PB3 –AMI Message Diagnostics**

The AMI is programmed using the GAI-Tronics ACT tool and the messages and tones are stored in no particular order on the device. In order for the ACC2500 to allow user selection of the preprogrammed alarms, it must read the table of contents from the AMI when necessary. To select a particular alarm, the ACC2500 operator simply scrolls to the desired alarm. However, to support the programming of preset zones with preset alarms, the message number of the desired alarm must be known. This diagnostic allows the installer/programmer to retrieve the message number as stored in the AMI of each message/alarm.

Upon entry into this diagnostic, the message number and alarm name of the first message in the list will be displayed as seen below.

<b>AMI MESSAGES</b> <b>21 : LOCK DOWN</b>
--

The message number displayed on the second line corresponds to the alarm name indicated. When programming the ACC2500 using GAI-Tronics' CARD Suite, this is the number that is used to configure a preset alarm.

Pressing the ALARM UP or DOWN buttons scrolls through the list of available alarms. Pressing TRANSMIT exits this diagnostic.

**Time Setting**

This feature allows the user to set the time in the AMI. The time is available in 24 hour format. To access the time setting feature, cycle the power to the ACC2500. When the display shows the unit's firmware version and the four programmable buttons are lit, press the TIME button. Upon access, the current hours, minutes and seconds will be displayed. The "\*" button moves the cursor to the left and the "#" button moves the cursor to the right. When all digits have been entered, press the TRANSMIT button to then enter the month, day and year. Again, when all digits have been entered, press the TRANSMIT button. Upon doing so, the unit will exit diagnostics.

## General Desk Set Overview

The ACC2500 is a multi-processor design employing state-of-the-art DSP technology to achieve superior performance over typical analog and single-processor designs. This allows for ultimate flexibility in audio processing.

The heart of the design consists of U1, the DSP; and U3, the microcontroller. The DSP is responsible for audio processing of receive and transmit audio. This includes line filtering, tone generation, audio level compression and setting, and audio routing.

The microcontroller is responsible for controlling the functions of the DSP, programming, the LCD display, keyboard scanning and general operational functions.

## Receive Audio

Receive audio is presented to the desk set through the line transformer providing for the necessary load. The audio is buffered and switched by U14. U14 controls the source of the receive audio.

The appropriate receive audio is then passed to the gain stage, consisting of U21 and U12. U12 provides the compression mechanism used by the DSP to keep the receive audio below the maximum level of approximately  $-6$  dBm. After the receive audio has been properly compressed, it is passed to A/D section of U15 where it is converted to digital for use by the DSP and also to P400-12 for data conditioning.

The input impedance is controlled by U10. When U10-1 is asserted, the input impedance is 560 ohms. When U10-1 is unasserted, the input impedance is bridging.

## Speaker Audio

Speaker audio is originated from the DSP in digital format. The DSP combines the receive audio, side-tone, and beep tones to generate the speaker audio.

The speaker audio is converted to analog using the D/A section of U17. It is then passed through the volume control stage consisting of U13 and U22 before being passed to the handset earpiece and the speaker amplifier, U18.

The microcontroller or the DSP can mute the speaker amplifier. The microcontroller mutes the speaker audio using U5-C8, in cases such as parallel mute or the user muting via a key press. The DSP uses a speaker squelch algorithm to squelch the speaker when no audio is being output to the speaker. This squelch will remain open for two seconds after no audio is present. The DSP then mutes the speaker using U1-88.

## Transmit Audio

Transmit audio is originated from the DSP in digital format. The DSP combines DTMF tones and voice audio to generate the transmit audio.

It is converted to analog by the D/A section of U15. Upon conversion to analog, the audio is passed through the line-out gain stage consisting of U11 and U10 for level adjustment. U10 also provides the proper line drive and line enable for the transmit audio.

U10-1 is the line-driver enable for the transmit audio. This provides for a 560-ohm transmit output impedance.

## Microphone Audio

The three sources for mic audio are the internal, handset, and audio accessory mic. The microcontroller controls which mic is used based on the source of the PTT. The selected mic audio is gated between the handset/internal and the audio accessory mic by U14 using the outputs of U5–C6. The selection of the handset and internal mic is controlled by U5–C5.

When U5-C5 is high, U25 will provide a high level of VMB or mic-bias voltage to the internal mic, thus, enabling the internal mic and disabling the handset mic. If U5–C5 is low, the internal mic will not have mic bias, but the handset mic will and, thus, the handset mic is selected.

The audio accessory port can be configured to provide a mic bias to the audio accessory. This is controlled by the microcontroller using U5–C7. Each mic audio is gain compensated by U22 so that the same level is presented to the mic gain-stage consisting U12 and U22. The audio is then presented to the A/D section of U17 where it is converted to digital for use by the DSP. The DSP compresses the mic audio using.

## Relay Control Module

The reference designators listed in this section refer to the relay control schematics unless otherwise stated.

The relay control module is used to provide closures out via relays and sense closures via closures to ground. The microcontroller provides closure-out information and reads closure-in information via serial data. Closure outputs are controlled by the data in U701. Closure senses inputs are read from U702.

To provide a closure on relay 1, the microcontroller asserts U701-15. This, in turn, drives the corresponding Q701 that provides the ground for the coil of K701. To provide a closure sense input on input 1, J701-5 must be grounded. This, in turn, is latched into U702 by the microcontroller where the microcontroller takes the appropriate action.

## Reset Circuit

Both the DSP and the microcontroller use the EPROM, U2. When coming out of reset, the DSP must boot its software from the EPROM. In doing so, it asserts U1-21, BMS, low, causing the microcontroller to remain reset.

After the DSP has completed loading its software from the EPROM, it no longer requires access to the EPROM. The DSP then disasserts BMS, allowing the microcontroller to come out of reset. The microcontroller then executes its software from the EPROM.

## General Description

GAI-Tronics' CARD Suite Programming Software, part number XAC1000A, is needed to program some of the functions and parameter settings of the ACC2500. It allows entry of operational programming data into your personal computer for transfer to the equipment. The programmed data can be retrieved, edited, archived, and printed in hard copy for record keeping.

## Connection

The GAI-Tronics equipment must be connected to your personal computer with the programming cable, part number XAC0004A, before the programming software can be used. To make this connection, attach the cable to the COM1 or COM2 connector on the computer. Connect the other end to the programming/data jack on the GAI-Tronics equipment.

## Installation

The minimum system requirement necessary to support the CARD Suite Software Application is Windows 95 or newer. However, CARD Suite is not compatible with Windows NT.

The CARD Suite Programming Application components are contained on CD-ROM. Please exit all other programs that are running until the installation is complete.

Place the CD in the PC's CD-ROM drive. If the "auto-run" feature on your CD-ROM drive is enabled, the CARD Suite menu screen should appear within a few seconds. If for any reason the installation does not start up automatically, it can be run from the Start menu.

Select the **START** button and then select **Run** from the Start menu. At the prompt, type **x:\Setup.exe** where **x** represents the drive letter that is associated with your CD-ROM drive. A CARD Suite icon should appear on the desktop display after successful installation.

## Reading the Unit

1. After opening the program, select the IPE2500 product icon, click on **File** in the toolbar and select **New Archive** to begin creating an archive.
2. Enter an archive description (name) and customer/site (name), select the method of creating the archive (default values or reading a connected unit), and click **Ok** button to create the archive.
3. View the **Help** file for programming guidance.

## CARD Suite Programming

To program a unit that has no saved archive, follow the steps for Reading the Unit on the previous page. To open an existing archive for editing, first click on the appropriate product icon, then double click on the archive you wish to edit from the list of saved archives. This will open the archive for that particular unit.

After all changes are made, you must save and close the archive prior to programming the unit with changes by clicking the OK button at the bottom of the screen.

After saving and closing the archive you can program the unit by selecting the archive from the list of saved archives, then selecting Program Unit under the Tools dropdown.

### Editing Screen

The status bar on the bottom of the window gives instructions on setting the desired parameter. Editing some parameters depends on the state of another parameter, such as in the Programmable Buttons screen. After changing a parameter, appropriate changes are automatically made to any other parameter on the screen that depends on it.

## Programming the ACC2500

Currently, the ACC2500 is programmed using the IPE2500A product icon. This product offers additional and separate features not found on the ACC2500.

### Zone Field Name

As discussed in the operations section of this manual, what is displayed for the zone field name can be changed to any 8-character alphanumeric string. To change this, under the Aliases/Function Tone Tables enter the desired description under Alias Name for F1. F3 through F16 are not used.

### Alarm Field Name

As discussed in the operations section of this manual, what is displayed for the alarm field name can be changed to any 8-character alphanumeric string. To change this, under the Aliases/Function Tone Tables enter the desired description under Alias Name for F2. F3 through F16 are not used.

### DTMF Setup

The DTMF paging parameters found under the Paging Parameters tab are used to control many aspects of the ACC2500/AMI interaction. After selecting the Paging Parameters tab, ensure that DTMF is selected under Paging Type. Only the fields discussed below are used.

### **Page PTT Pretime**

The Page PTT Pretime is used to compensate for system delays in systems that may include radios or repeaters. This pretime begins after the AMI is commanded to begin transmission and allows the system to stabilize before generation of DTMF sequences. Normally, this setting is 0 ms and the ACC2500 includes a built-in pretime for a hard-wired system or one where no delays are present. If the initial DTMF sequence broadcast is being chopped off at the receiving unit, this pretime should be increased appropriately.

**Zone Address Length**

The GAI-Tronics addressable speakers and broadcast devices use DTMF signaling for activation. The addresses of these units should be programmed for the reception of the same number of address digits. When a zone is to be activated, the proper number of address digits followed by a DTMF “#” are sent to the zone. This number of digits or address length should be entered in the Max. Digits from Keypad. Note that the ACC2500 appends the DTMF “#” to the end of the zone address.

**Preamble Digits**

If all zones in the system start with a particular sequence followed by unique digits for each zone or unit, these digits can be entered in the Preamble Digits field. When a zone is then activated, the operator must only enter the unique digits before pressing TRANSMIT. The ACC2500 will first generate the Preamble Digits followed by the digits entered by the operator. Note that if preamble digits are entered, the Zone Address Length must be only the number of digits entered by the operator and not include the number of digits in the preamble.

**Zone Activation Duration**

The GAI-Tronics addressable speakers and broadcast devices have an inactivity timer that keeps them active in the absence of a contact closure or audio detection depending on the particular installation. To coordinate this time with the ACC2500 and prevent generation of DTMF zone addresses when not necessary the TALK NOW Time should be set to the same duration as that of the units. This duration is in 5-second increments and will require that the field units be set to the same 5-second granularity. If set to 0, the ACC2500 will generate the DTMF ZONE address each time a zone is addressed. Note that this will be the default activation time for any zone and can be overridden using preprogrammed zone aliases.

**DTMF Digit Time**

The duration of the DTMF digits used to activate a zone is controlled by the DTMF Interdigit Time.

**Restrict Entry of Manual Zones**

By default, the operator can select any numerical zone using the numeric keypad. To restrict manual selection of a zone disable Allow Manual Paging.

**Restrict DTMF Over Dial**

By default, the operator can over dial DTMF when a zone is active. To restrict over dialing of DTMF when a zone is active disable Allow Immediate DTMF Paging.

**Preprogrammed Zone/Alarm Aliases**

The ACC2500 supports preprogrammed aliases for zones or zones plus alarms using the Alias Table of the IPE2500. These allow the operator to select a zone or zone and alarm using names instead of numerical zone number and message numbers. They can also be used to restrict, along with restriction of manual zones and DTMF over dial, what the operator may activate or broadcast in the system.

**Preprogrammed Zone / No Alarm**

To preprogram a zone to allow the operator to select a zone via name, press the Add Alias button on the Alias Tables tab. Enter up to an 8-character alphanumeric name under Alias Name and press the enter key on the computer keyboard. Under Paging Type, select DTMF. Under Talk Time, enter the desired activation duration for the zone being programmed. If set to zero, the previously described zone activation duration will be used. If longer than the zone activation duration, this duration will be used.

Next, select Disabled under PTT Frequency and press Enter. Deselect Keep Page PTT Freq and press Enter. Now the address of the zone being programmed is entered. This field will allow up to 12 digits to be entered. If no alarm is being associated with this alias, the exact number of address digits should be entered. Enter the address of the zone being programmed and press enter. The new alias is added to the list and will be accessible by the operator after programming and during operation. Note that only one address may be entered in each alias. If desired, aliases may be grouped using a group alias. Refer to CARD Suite help for more information.

### **Preprogrammed Zone with Alarm**

It is possible to not only preprogram a zone with a name but to also associate a particular alarm with that zone using the same alias. To do this, enter a new alias as described when no alarm is associated with the alias. However, before entering the zone address and hitting enter, enter the zone address followed by the desired message number to be used for the alarm. This message number is retrieved using the AMI Message diagnostic.

For example, an alias is desired for zone 4, address 123, that will be used to broadcast an all-clear message, message 27, to the zone. The Capcode entered for this alias should be entered as 12327. Since the number of digits set by the Max Digits From Keypad under the Paging Parameters Tab had been set to 3, the ACC2500 will extract the address of 123 and a message number of 27 from the new alias. Note that all digits following the address in the alias will be used to determine the message number. For example the capcode of 123001, 12301 and 1231 will all address zone 123 and broadcast message 1.

### **Programmable Buttons**

The ACC2500 includes four programmable buttons that can be programmed for up to eight functions. The second set of four is accessed in conjunction with the CTL button combination. Supported functions of the ACC2500 are button remap, quick page, or output control\* and mute. Button remap will allow any button to be remapped to the button. Mute allows for a timed or infinite mute function of the speaker. Quick Page is used to associate a preprogrammed alias with or without alarm to the particular button.

To associate an alias with a programmable button, selected the desired button and set the function to quick page. Disable Manual Page and selected the desired alias from the Paging Alias pull-down. Note that when adding to or deleting aliases from the Alias Tables tab, it may be necessary to reset these programmable buttons to the desired alias.

\*Requires XRC0001A to be installed. Relay 1 is used for connection of backup ACC2500 unit.

### **Other Necessary Programming Settings**

The following parameters must be set in order for the ACC2500 to work properly with the AMI:

- Tone Control/TX Function Tone tab, Half/Full Duplex should be set for Full. Dup.
- Tone Control/TX Function Tone tab, 2/4 Wire should be set for 4 Wire.
- Tone Control/TX Function Tone tab, Type of Interface should be set for Tone.
- Deskset Parameters tab, Accessory PTT Polarity should be set for Low
- Deskset Parameters tab, Accessory Monitor Polarity should be set for Low
- Deskset Parameters tab, Line Termination should be enabled for at least one ACC unit in the chain. If only one ACC2500 is used, it should be enabled on that unit. If backup units are used, the last unit physically farthest away from the AMI should have Line Termination enabled.



## Troubleshooting the ACC2500 Desk Set

The following is a list of potential problems you may encounter and possible solutions.

Problem	Possible Solution
The unit has no LED or LCD display	Ensure that the unit is receiving dc power.
	Check for a blown fuse.
The keyboard does not respond.	Ensure that the PTT or monitor input of any audio accessory is not activated.
No, low, or distorted transmit audio.	Ensure that the microphone sensitivity is properly adjusted for the microphone in use.
	Ensure that the line output level is properly adjusted.
AMI Audio is low or distorted.	Ensure that the audio level is properly adjusted for the particular speaker.
	Ensure that the line-input sensitivity is properly adjusted.
No or low transmit audio	Ensure that the leased line being used does not have excessive line losses.
Display shows "AMI UNRESPONSIVE."	The RS-232 data connection to the AMI has been lost or the AMI is not communicating. This is normal during the AMI boot cycle.
Display shows "BACKUP WAITING."	The unit has been configured as a hot standby unit and is not currently communicating with the AMI. Upon connection to the AMI via primary ACC2500 failure or cable, the unit will reset and begin normal operation. Refer to the Diagnostics section of this manual for more information.

## Fuse Replacement



**For continued safe operation, replace fuses with the same type.**

- **Fuses F1 and F2 are Bussmann C515S 1.25A SB 2AG.**
- **Fuse F401 is Bussmann GMA 1A 5X20MM.**



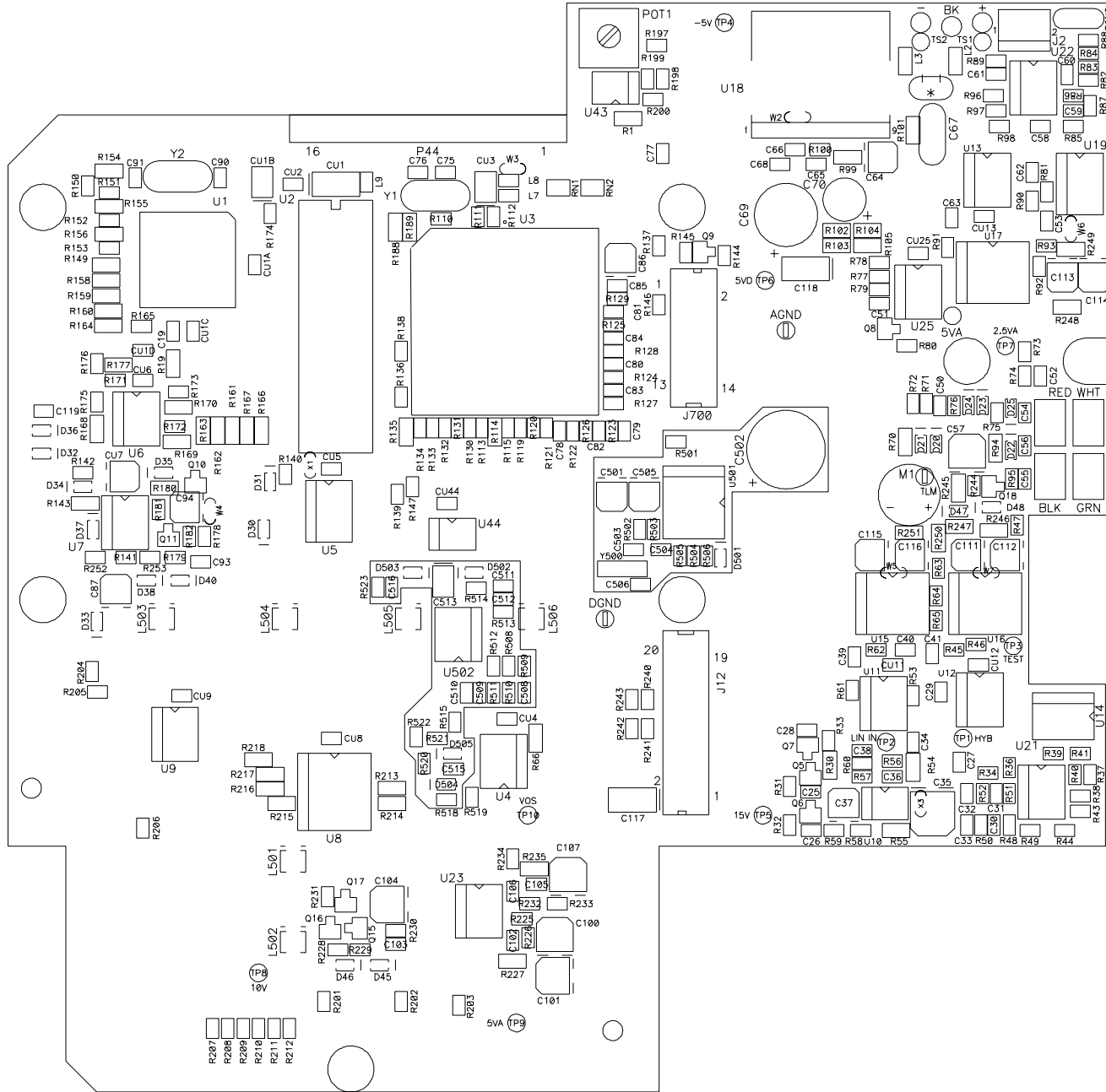

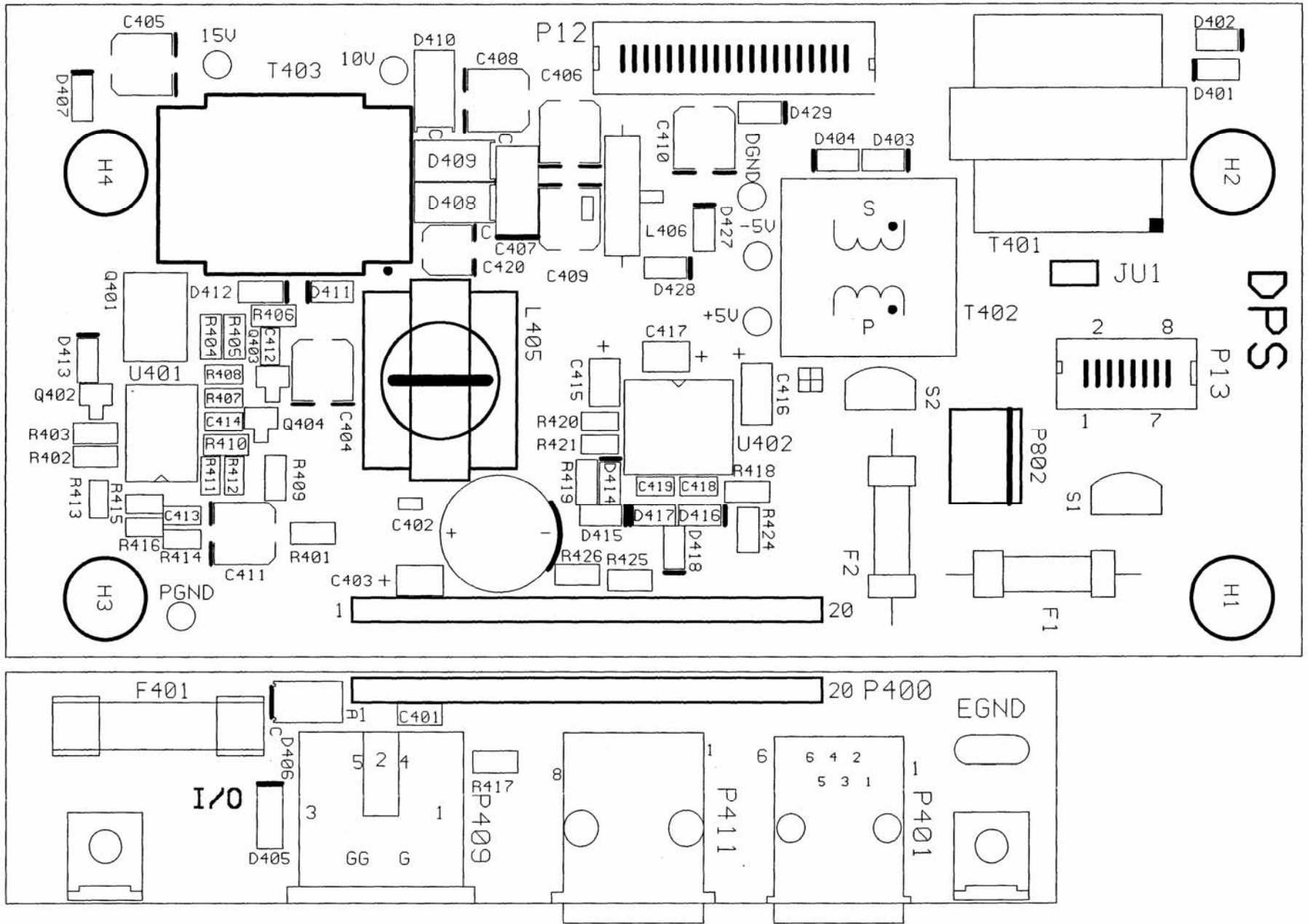

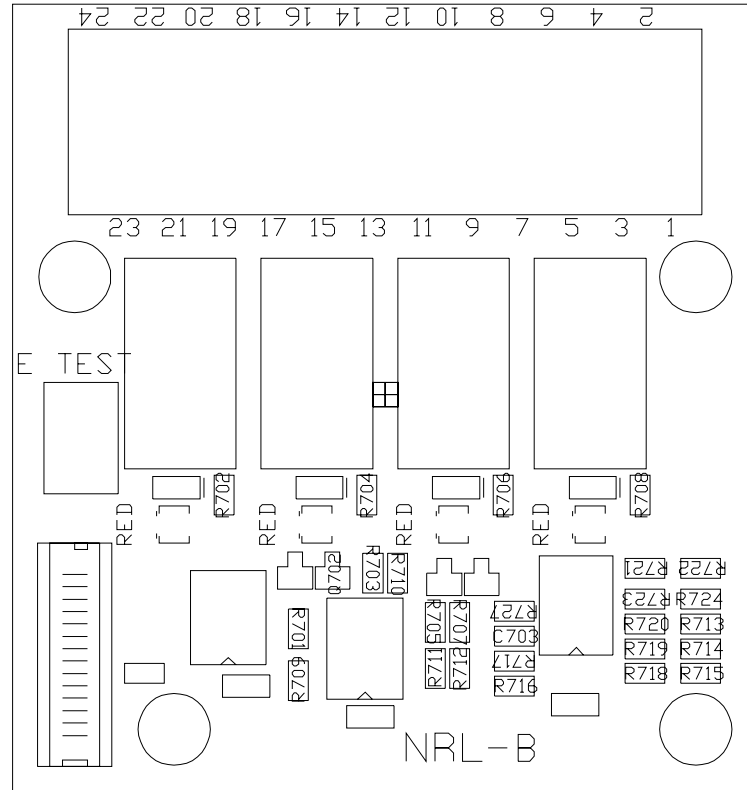



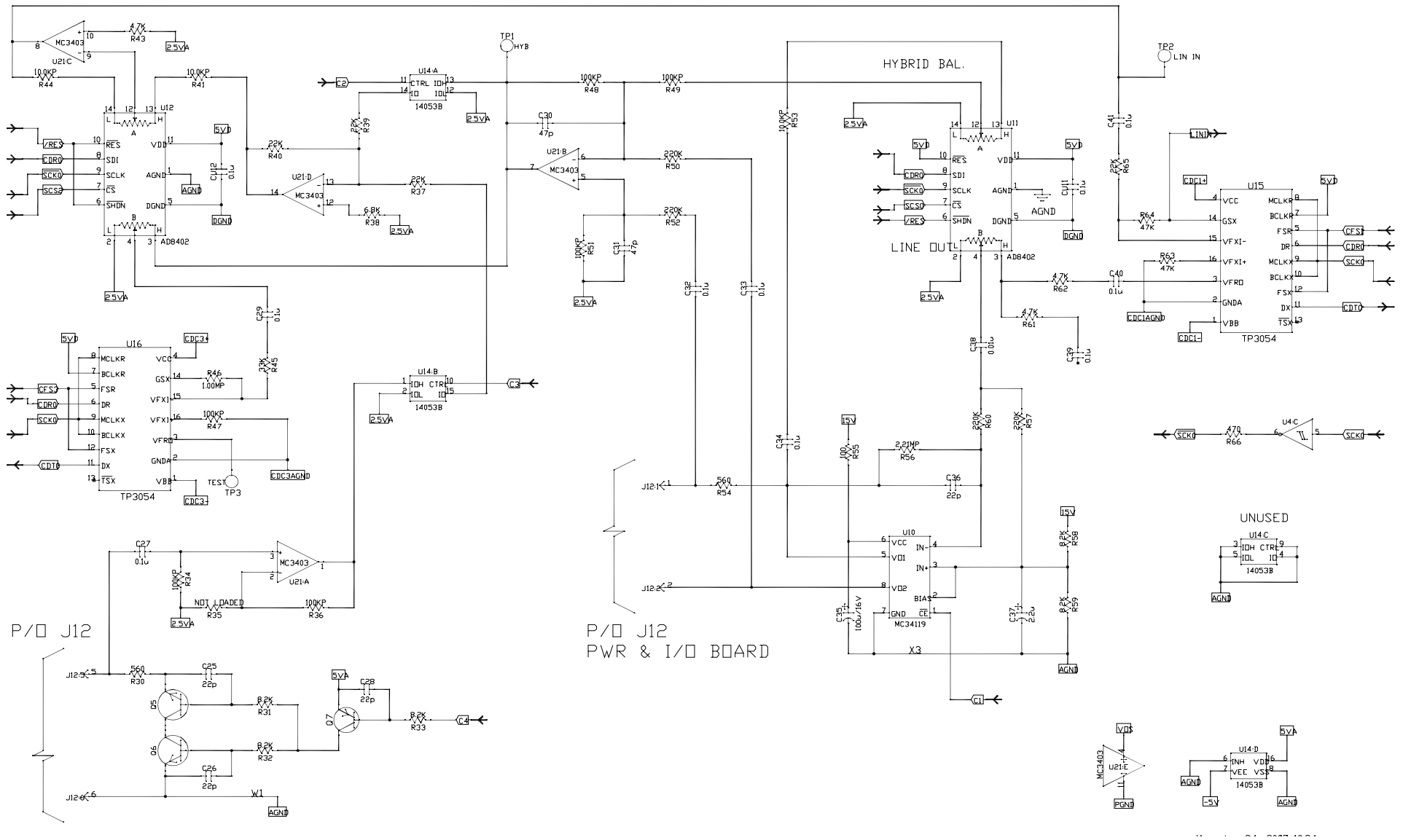

Desk Set - Line Interface - Sheet 1



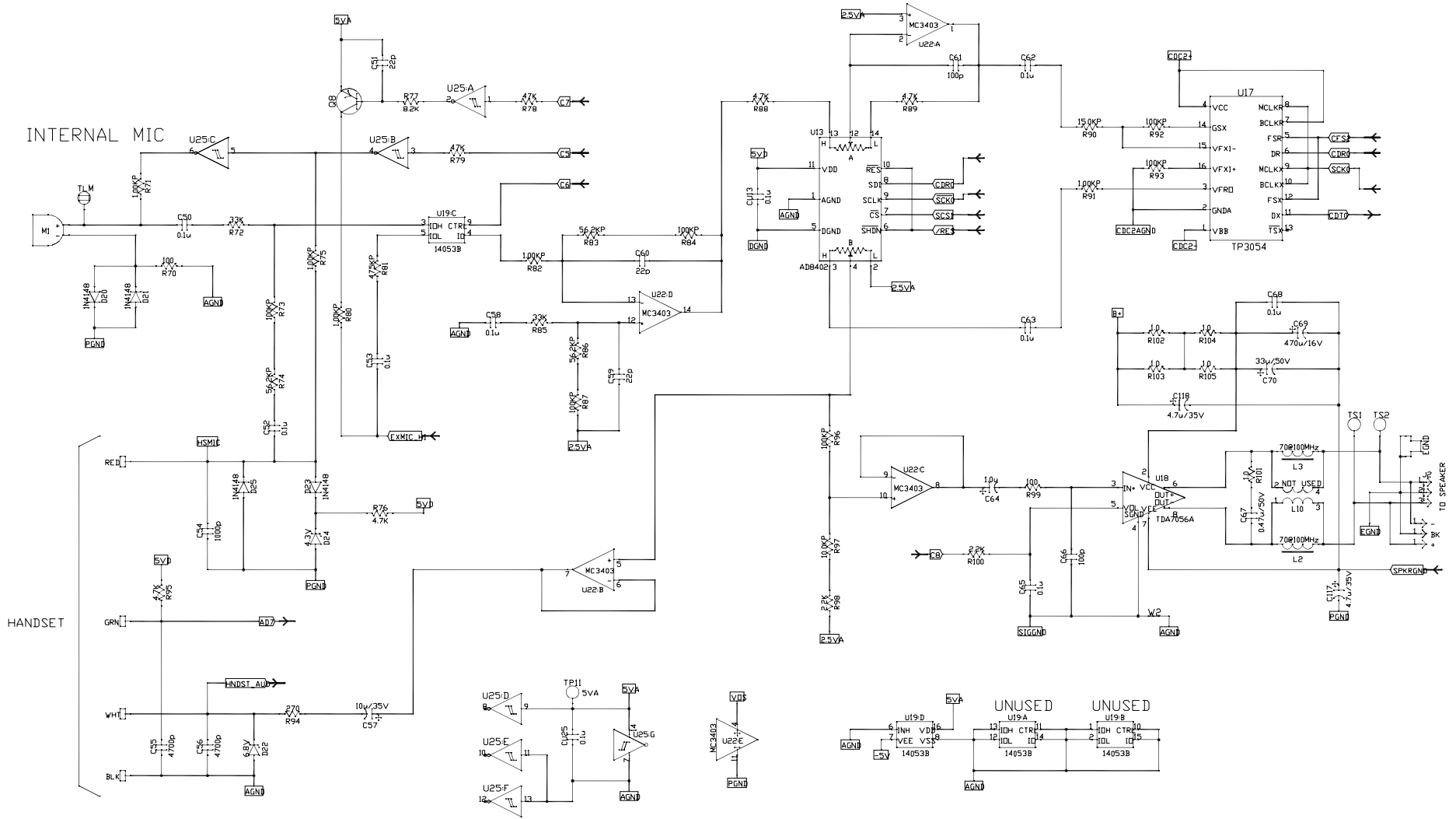

Desk Set - User Audio I/O - Sheet 2

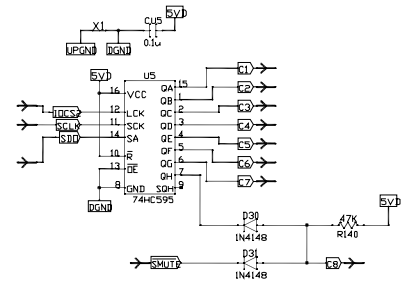
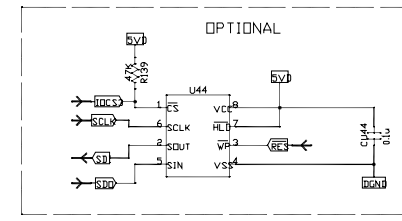
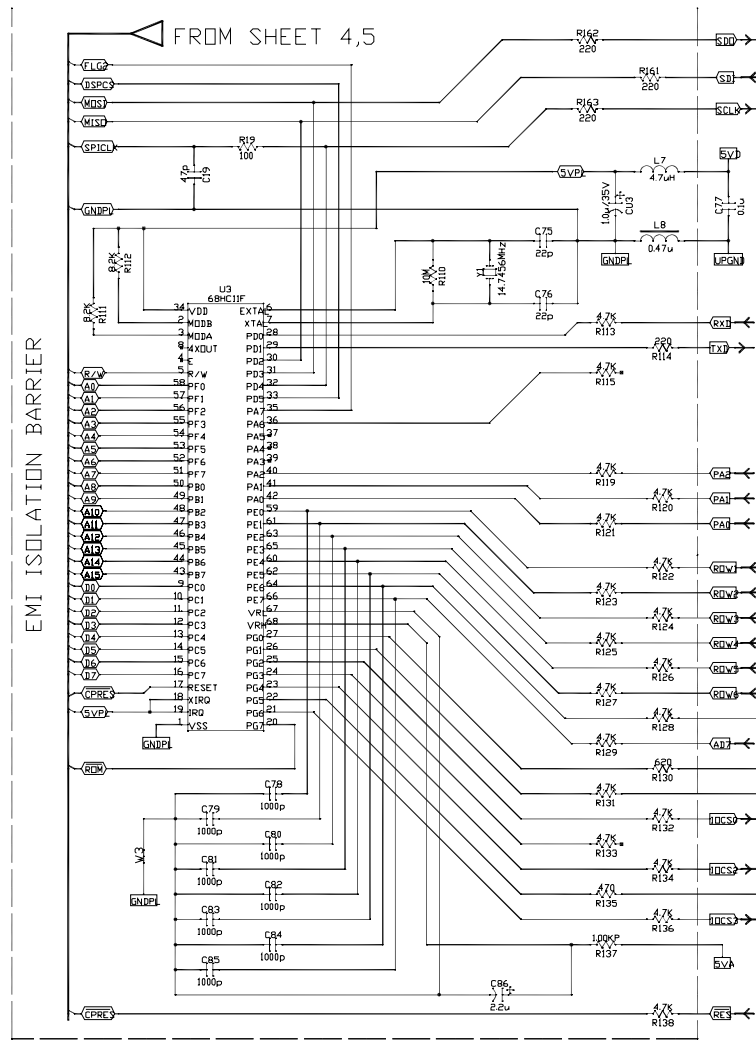

N.V.RAM PROTECTION

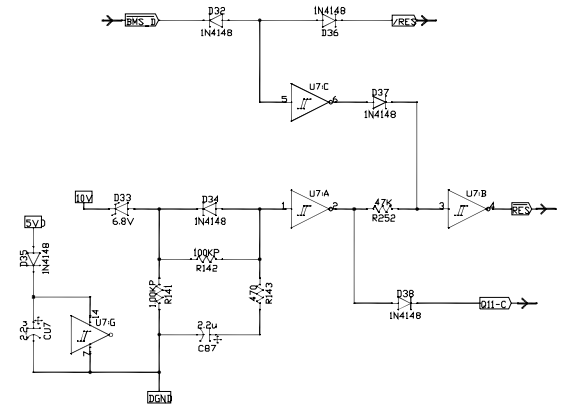

OPTION MODULE

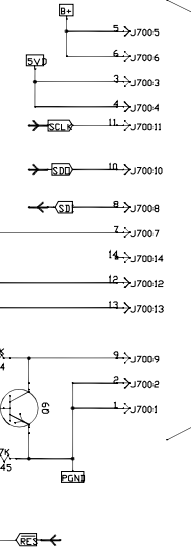

Desk Set - Control Microprocessor I/O - Sheet 3

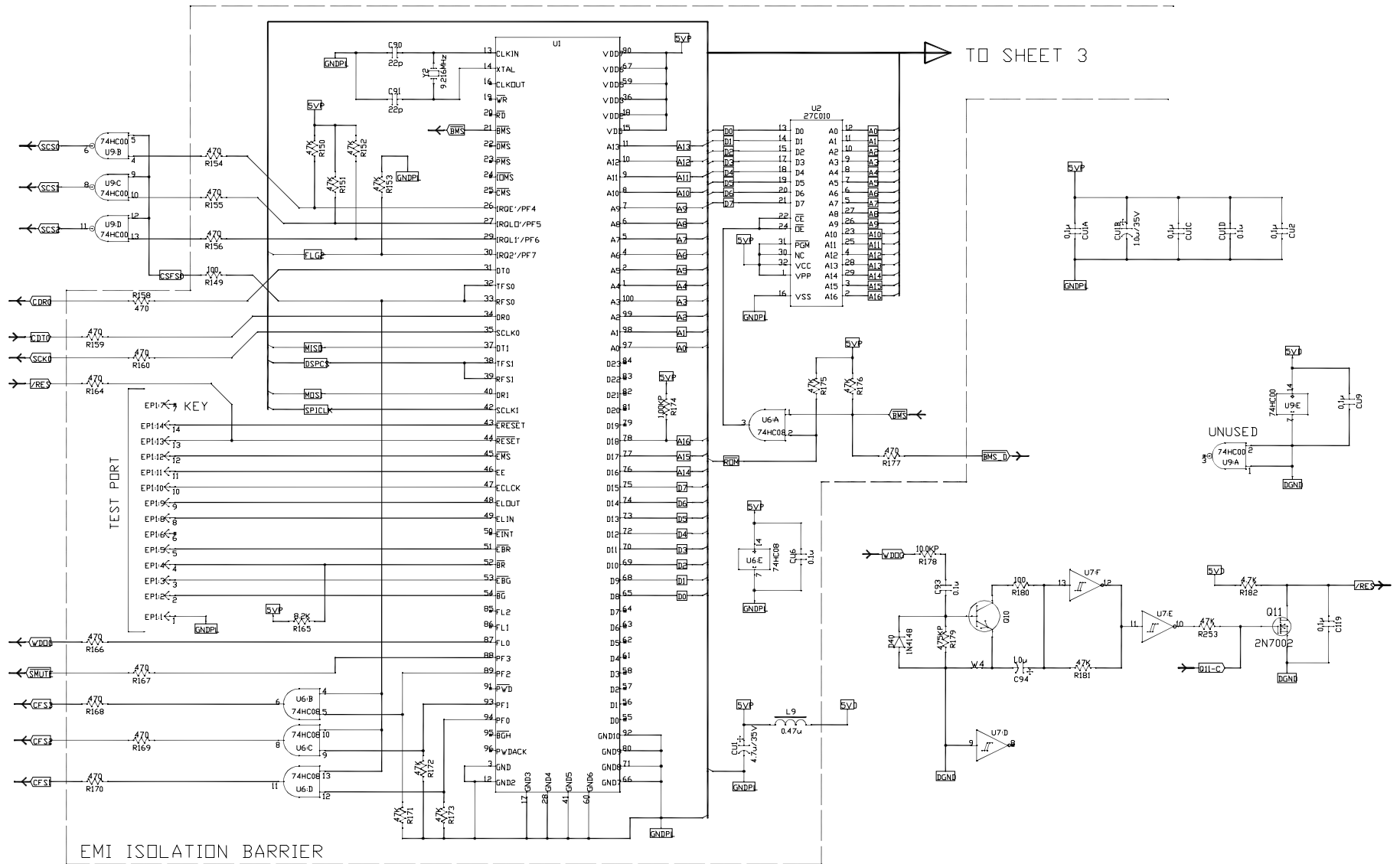

Desk Set - DSP Block - Sheet 4

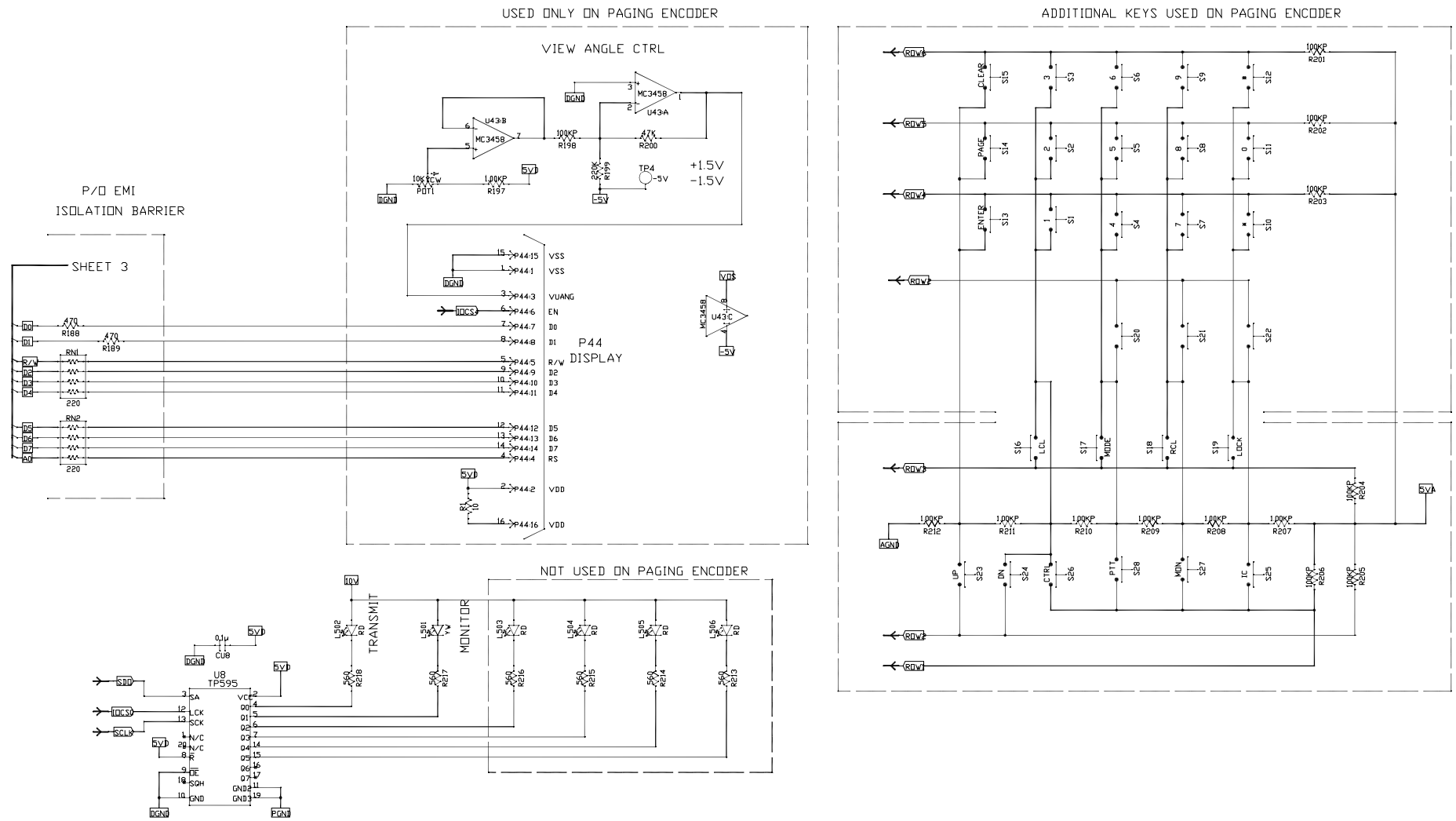

Desk Set - Tone Key Panel - Sheet 5

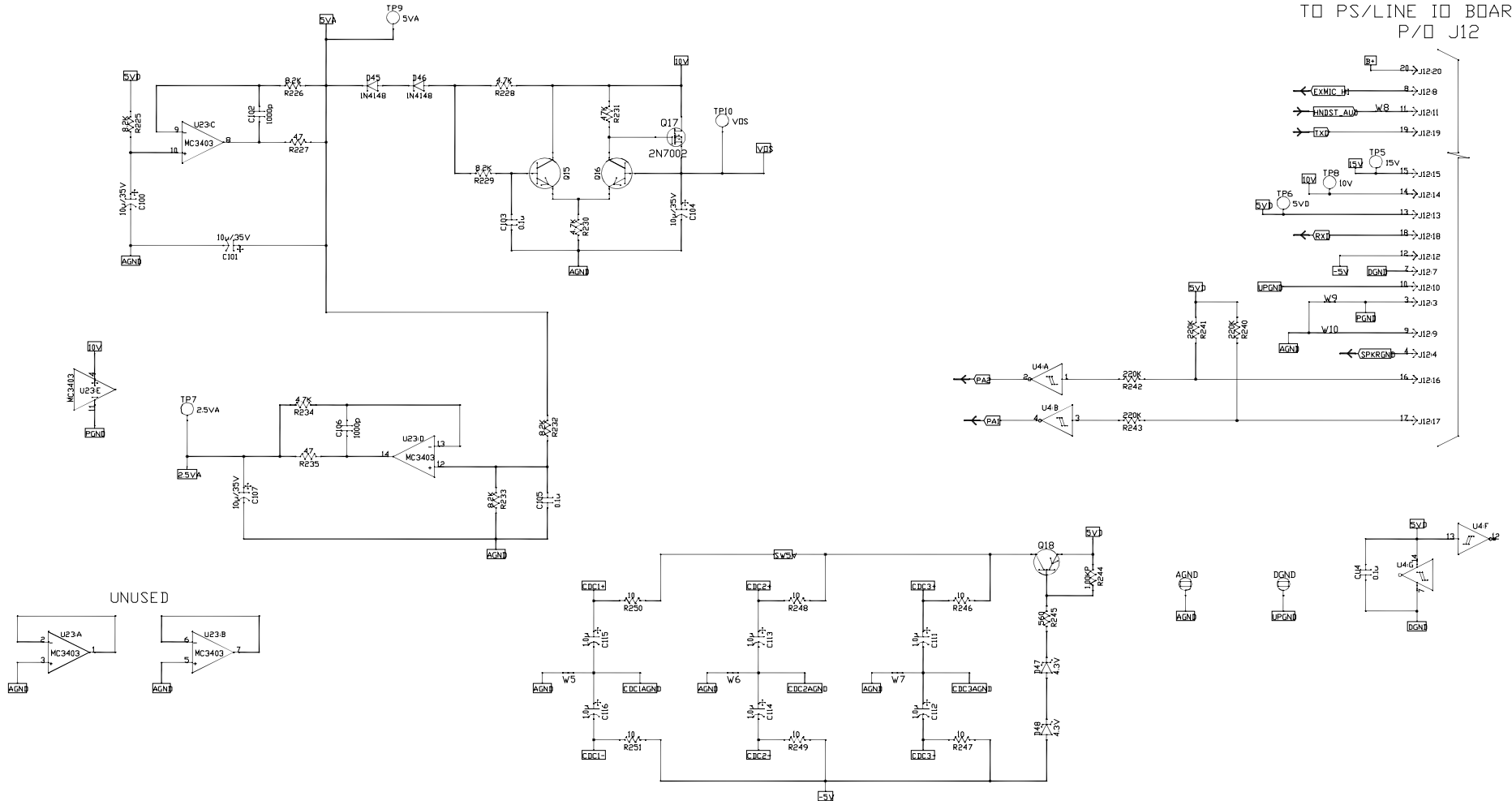



Schematic - Sheet 7

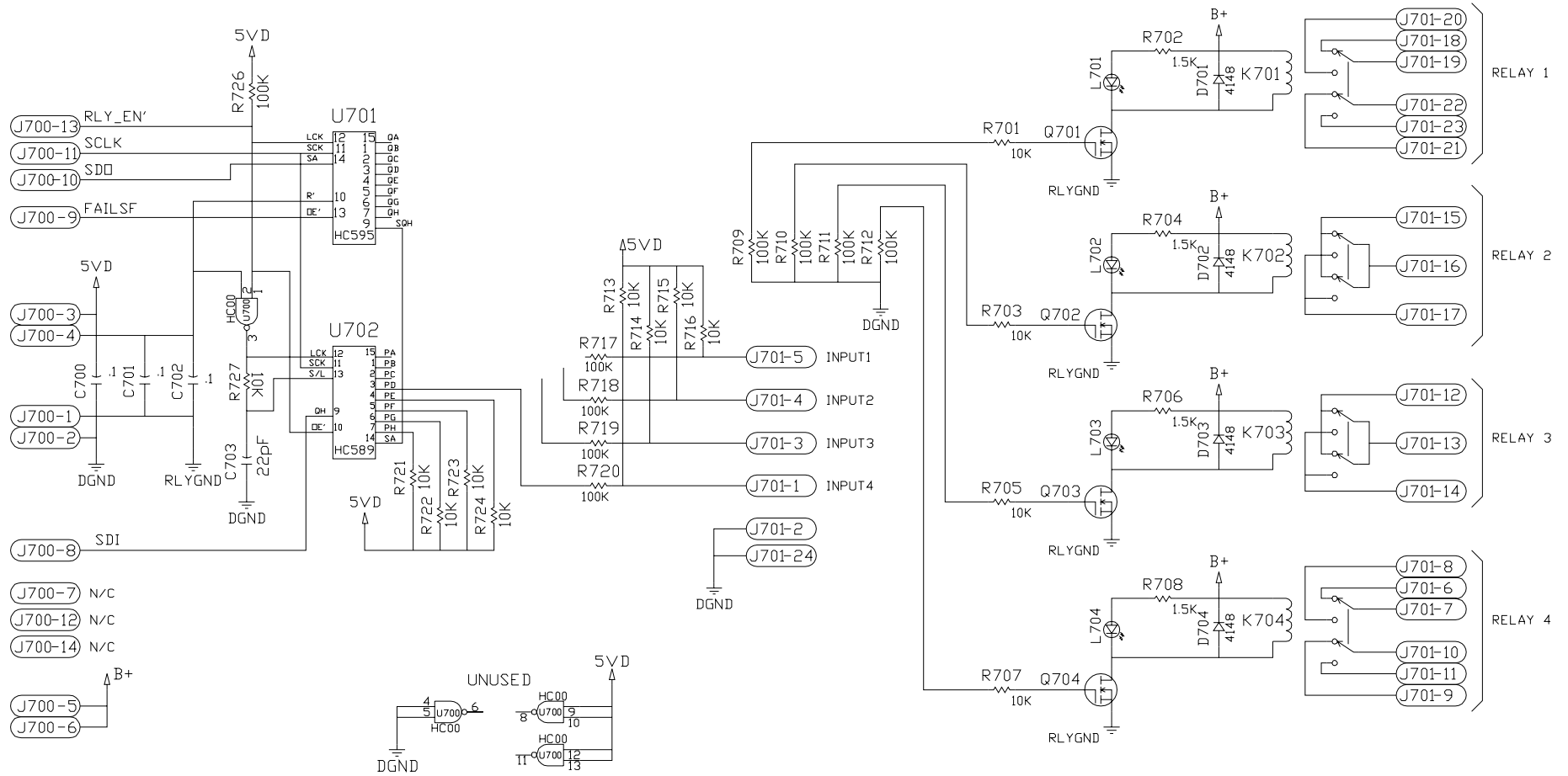

---

# Notes

---

---

---

---

---

---

---

---

---

---

---

---

---

---

---

---

---

---

---

---

---

---

---

---