



GAI-TRONICS®
A HUBBELL COMPANY

Model 210 Series Analog Corridor Telephones

Confidentiality Notice

This manual is provided solely as an installation, operation, and maintenance guide and contains sensitive business and technical information that is confidential and proprietary to GAI-Tronics. GAI-Tronics retains all intellectual property and other rights in or to the information contained herein, and such information may only be used in connection with the operation of your GAI-Tronics product or system. This manual may not be disclosed in any form, in whole or in part, directly or indirectly, to any third party.

General Information

The Model 210 Series Analog Corridor Telephones offer standard line-powered telephone operation in a rugged package that is fabricated of brushed stainless steel and is less than 3 ½-inches deep (measured from the mounting surface). All models are equipped with armored cord handsets and volume control via handset pressbar or a pushbutton.

The Model 210-001 and 210-002 Corridor Telephones (see [Figure 1](#)) offer volume control handsets with a 29-inch armored swivel cord, a keypad, and a ringer with loudness control. The Model 210-002 is approved for use in Class I Division 2 Groups A, B, C, and D areas. The Model 210-001BH and 210-001BHAC Behavioral Health Telephones (see [Figure 2](#)) are equipped with 12-inch and 15-inch (respectively) armored cord handsets, a keypad, a volume control pushbutton, and a ringer with loudness control. The Model 210-003 Autodial Corridor Telephone, and the Models 210-003BH and 210-003BHAC Behavioral Health Auto-Dial Telephones feature 29-inch, 12-inch, or 15-inch (respectively) armored cord handsets, volume control pushbuttons, and ringers with loudness control (see [Figure 3](#)).

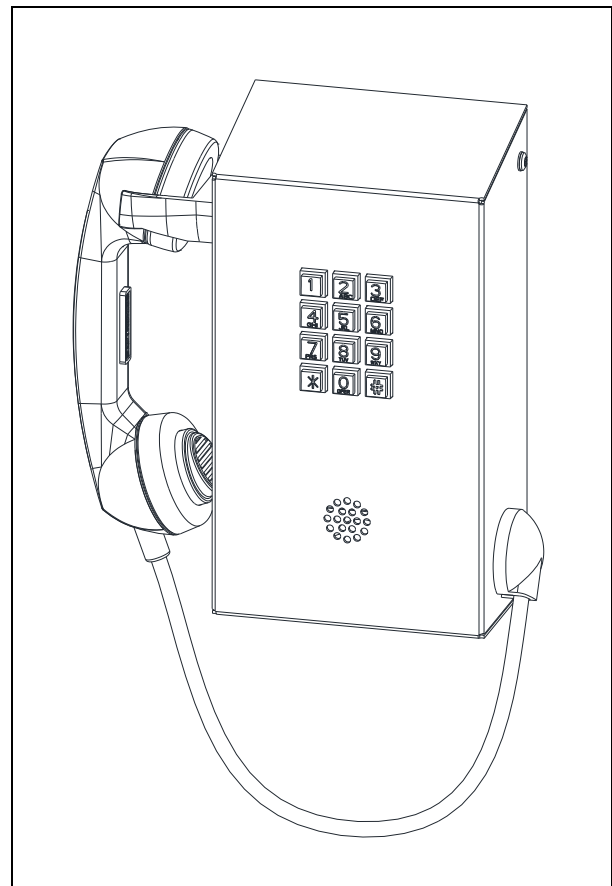

(Table 1 lists the features and functionality of each of the Model 210 Series Telephones.) Figure 1. Models 210-001/002 Corridor Telephones

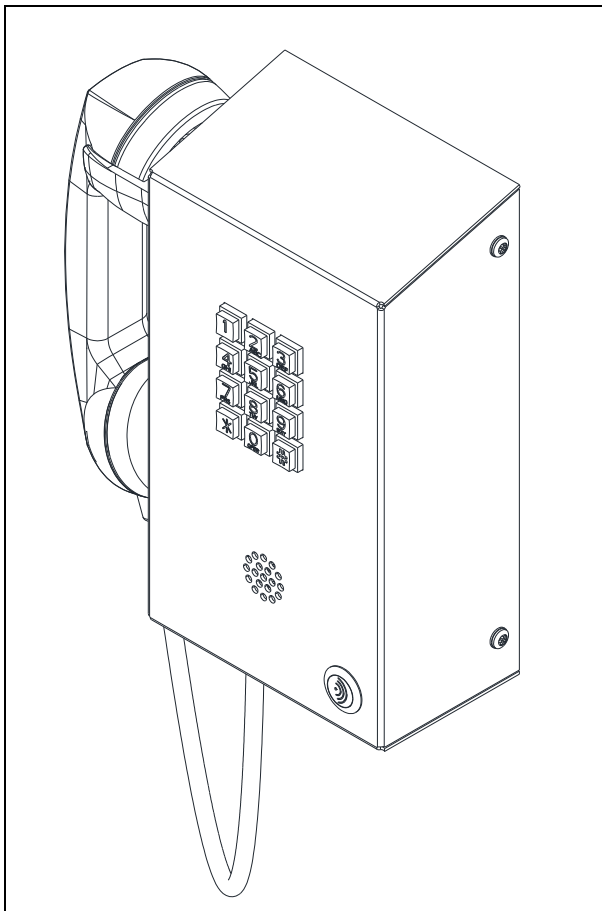

Figure 2. Model 210-001BH/-001BHAC Behavioral Health Telephones

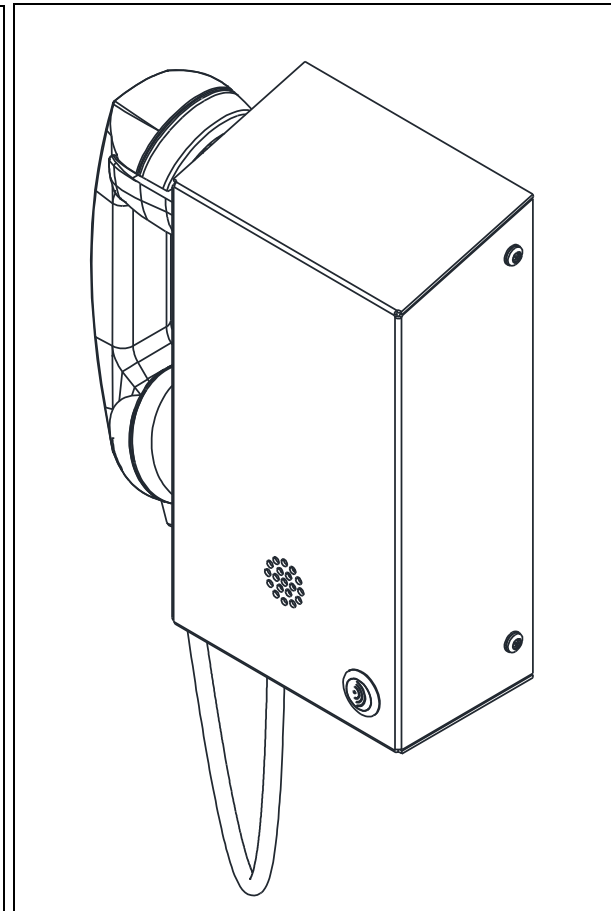

Figure 3. Model 210-003/-003BH/-003BHAC Autodial Behavioral Health Telephones

Table 1. Model Chart

Model	Description
210-001	Corridor Telephone , wall-mount with keypad and 29-inch armored swivel-cord volume-control handset.
210-001BH	Behavioral Health Corridor Telephone , wall-mount with keypad, 12-inch armored cord handset, and pushbutton volume control.
210-001BHAC	Behavioral Health Corridor Telephone , wall-mount with keypad, 15-inch armored cord handset, and pushbutton volume control.
210-002	Corridor Telephone , wall-mount with keypad and 29-inch armored swivel-cord volume-control handset. Approved for Class I Division 2 Groups A, B, C, and D locations.
210-003	Auto-dial Corridor Telephone , wall-mount with 29-inch armored cord handset and volume control pushbutton.
210-003BH	Behavioral Health Auto-dial Corridor Telephone , wall-mount with 12-inch armored cord handset and volume control pushbutton.
210-003BHAC	Behavioral Health Auto-dial Corridor Telephone , wall-mount with 15-inch armored cord handset and volume control pushbutton.



The GAI-Tronics' Model 210 Series Corridor Telephones are ideally suited for installation in any area requiring the ADA (Americans with Disabilities Act) maximum protrusion depth of 4 inches (corridors, hallways, passageways, etc.). The BH (Behavioral Health) models are ideal for use in healthcare facilities where a shorter handset cord length is required.

These corridor telephones can be surface-mounted in any indoor area requiring telephone communication. The unit's rear mounting plate provides telephone line access, eliminating visibility of or access to the cabling. Additionally, the corridor telephone is secured with tamper-resistant hardware to prevent vandalism.

Installation Guidelines

When installing any GAI-Tronics telephone equipment, please adhere to the following guidelines to ensure the safety of all personnel:

- NEVER install telephone wiring during a lightning storm.
- NEVER install telephone jacks in wet locations unless the jack is specifically designed for wet locations.
- **Install a UL Listed lightning arrestor** on any phone installed where the phone or phone cable is at risk of being exposed to lightning strikes. The lightning arrestor must be installed as close to the phone as possible to maximize the protection. The lightning arrestor must not be installed within the enclosure supplied with the phone.
- NEVER touch uninsulated telephone wires or terminals unless the telephone line has been disconnected at the network interface.
- USE CAUTION when installing or modifying telephone lines.
- Install UL Listed telephone line suppressor (customer-supplied) on the telephone line.

 **CAUTION**  —Do not install this equipment in areas other than those indicated in the Approvals section of this manual. Such installation may cause a safety hazard and consequent injury or property damage.

Installation

Mounting and Wiring Instructions

1. Use a GAI-Tronics Model 233-001 Security Screwdriver to remove the four tamper-resistant cover panel screws. Set the screws aside to be reinstalled in Step 6.
2. Remove the front cover assembly to expose the four mounting holes on the mounting panel. These holes accept #10-32 screws (customer provided). The length of these screws will depend on the mounting surface (see Figure 4).

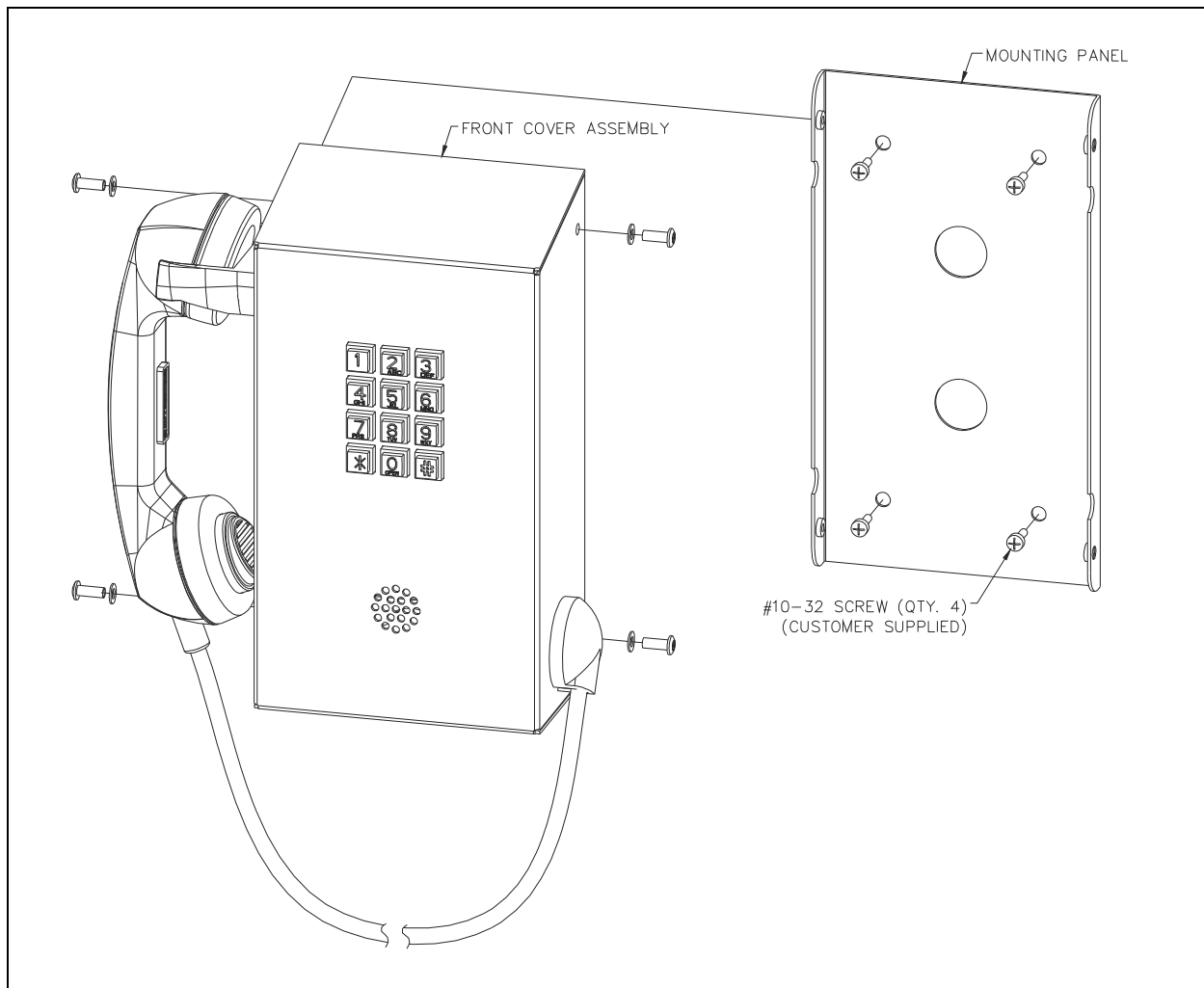

Figure 4. Mounting Details (Model 210-001 Shown—Same for all models)

3. Two 1-inch entry holes are provided on the mounting panel for cable entry.
4. Connect the modular telephone cord, or direct subscriber telephone line, to the PCBA terminal strip.
5. Connect the free end of the modular telephone cord to the incoming subscriber line using the appropriate mating connector (if utilized).
6. Replace the front cover assembly, reinstall and tighten the four front cover screws retained from Step 1.
7. Check the telephone operation by calling to and from another telephone.

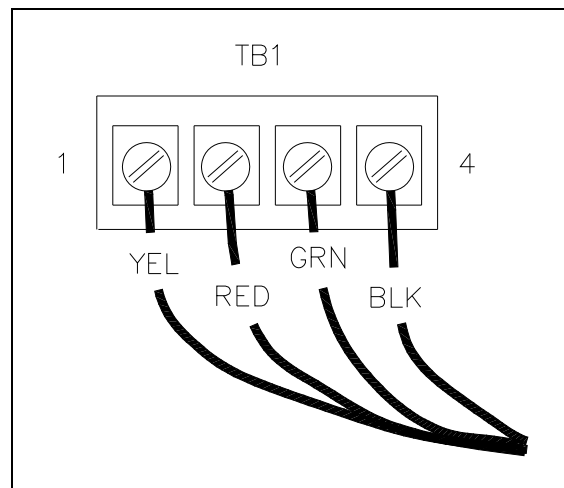

Figure 5. Telephone Cord Connection to PCBA Terminal Strip

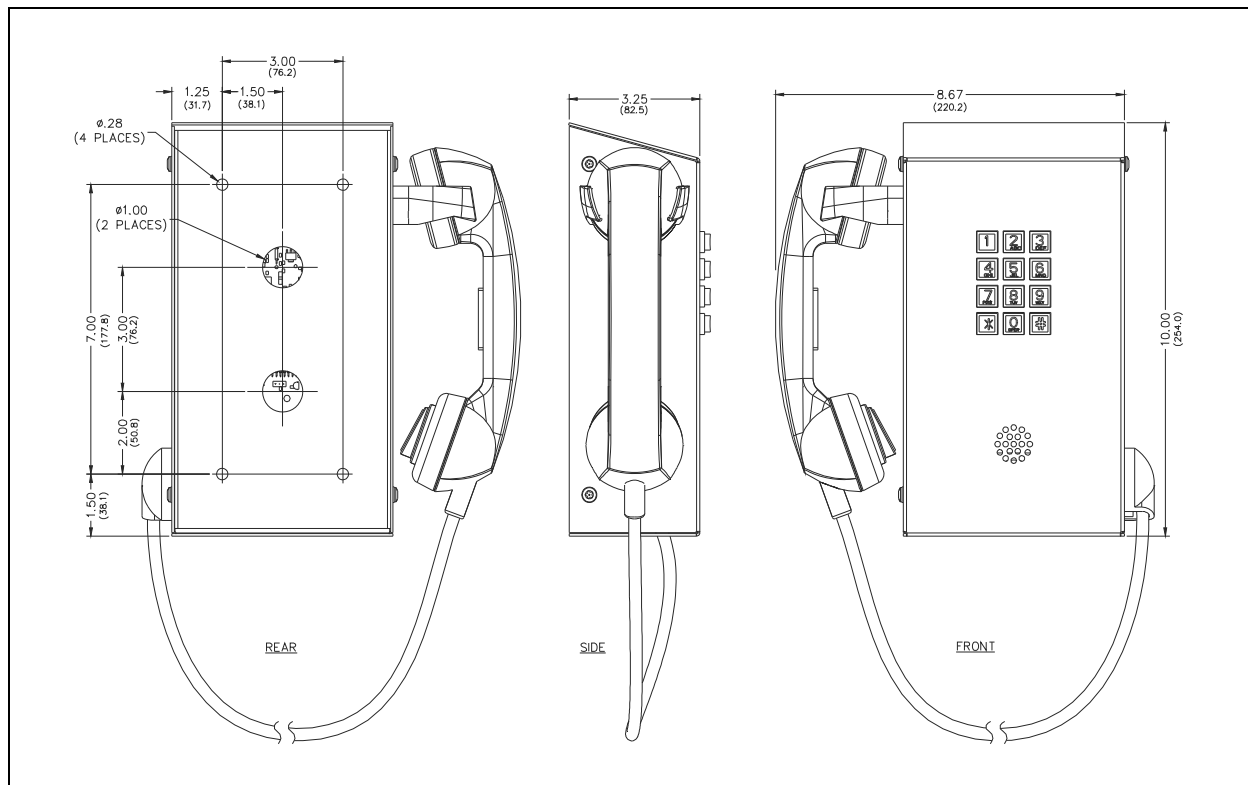

Figure 6. Corridor Telephone Outline Drawing
(Model 210-001 Shown—All models are dimensionally the same.)

Programming Auto-Dial Numbers (Applicable to Models 210-003/-003BH/003BHAC)

1. Remove the front panel assembly by following the appropriate instructions provided in this manual for your phone.
2. Insert the supplied portable keypad and cable into J7.
3. The plug-in jumper on the connector header J2 should be installed between pins 2 and 3 (default).
4. Connect the telephone line cable from the telephone to an active telephone line.
5. Remove the handset from the cradle (off hook) and enter the desired telephone number into memory using the keypad mounted on the back of the front panel assembly.
6. Once the number is entered, replace the handset in its cradle (on hook) and move the plug-in jumper on J2 to pins 1 and 2.
7. Test the auto-dial number by removing the handset from its cradle (off hook)—the telephone should automatically dial the preprogrammed number.
8. Once the auto-dial number is verified, remove the keypad and cable and store in a safe location.
9. Reattach the front panel to the enclosure.

NOTE: The programmed number remains in memory until it has been reprogrammed. Disconnecting the telephone line does not erase the programmed number. The number is stored in a nonvolatile electronic memory. Standby batteries are not required.

Operation

1. Lift the handset to place a call.
2. The handset receiver volume is adjustable using the handset pressbar or the volume control pushbutton located on the front of the telephone. The volume increases with each button press in six steps. Pressing the volume control a seventh time will reset the volume to the original level. When the handset is returned to its cradle, the receiver volume is returned to the initial volume setting. This behavior can be changed by the volume control jumper setting. (See the Volume Control Jumper Setting section for information on configuring the jumper.)
3. **Keypad Models 210-001, 210-001BH, 210-001BHAC, and 210-002**—Dial the desired number.
Non-Keypad Models 210-003, 210-003BH, and 210-003BHAC—The telephone will automatically dial a preprogrammed number or be connected to a system provided ring-down circuit. (See the Programming Auto-Dial Numbers section.)
4. After completion of the call, place the handset on-hook.

Ringer with Volume Control

The volume level of the ringer can be adjusted. Follow the steps in the “Mounting and Wiring Instructions” section on Page 3 to open the enclosure. The ringer is mounted on the bottom of the enclosure and has a volume control knob. This knob can be turned to open or close the audio ports to increase or decrease the volume by 15 dB. (See Figure 4.)

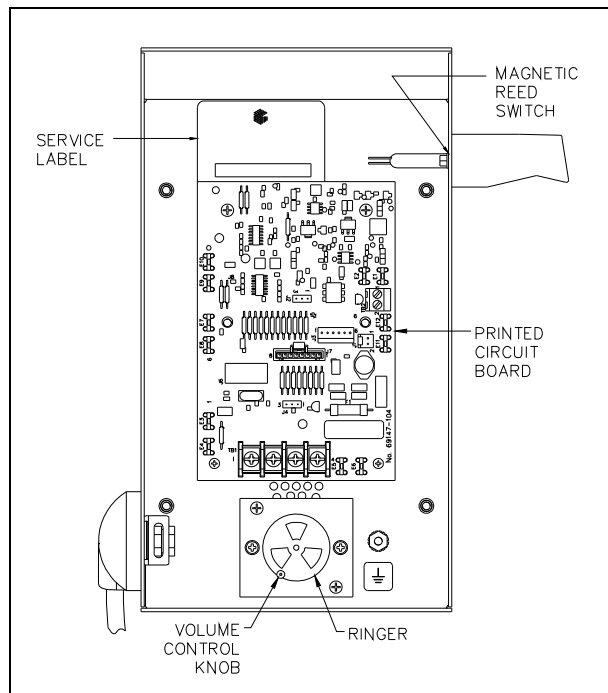

Figure 7. Model 210-001 Interior View

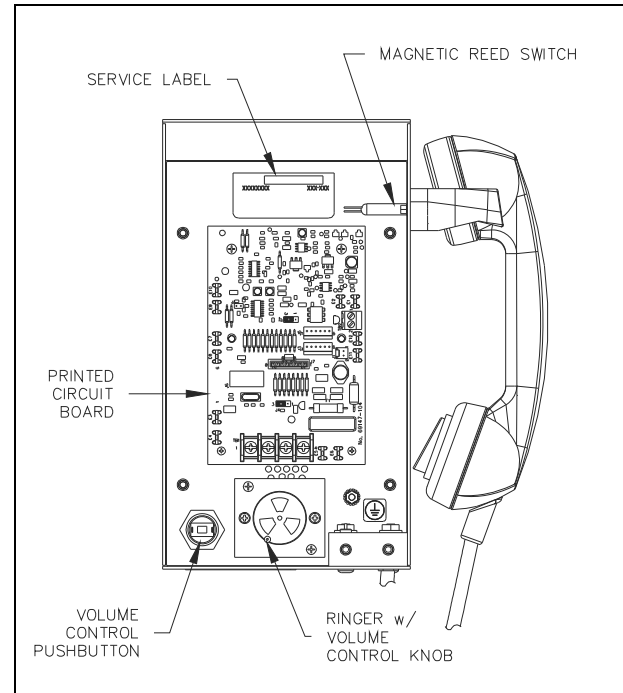

Figure 8. Models 210-00xBH/-00xBHAC Interior View

Volume Control Jumper Setting

The handset receiver volume control is factory set to default to its original setting (0 dB) when the telephone is hung up. To save the volume control setting upon hangup, jumper J4, which is factory set at positions 2 and 3, must be moved to positions 1 and 2 (see Figure 9)

Auxiliary Output

Each telephone includes one isolated solid state switch capable of switching a maximum of 48 V dc, 125 mA or 28 V ac_{RMS}, 80 mA_{RMS}. TB2 (AUX OUT) on the industrial telephone PCBA provides the connections for the auxiliary output (see Figure 9).

The auxiliary output allows peripheral equipment, such as beacons, video cameras, and alarm generators, to be activated when the handset is off hook. The relay remains energized for the duration of the call.

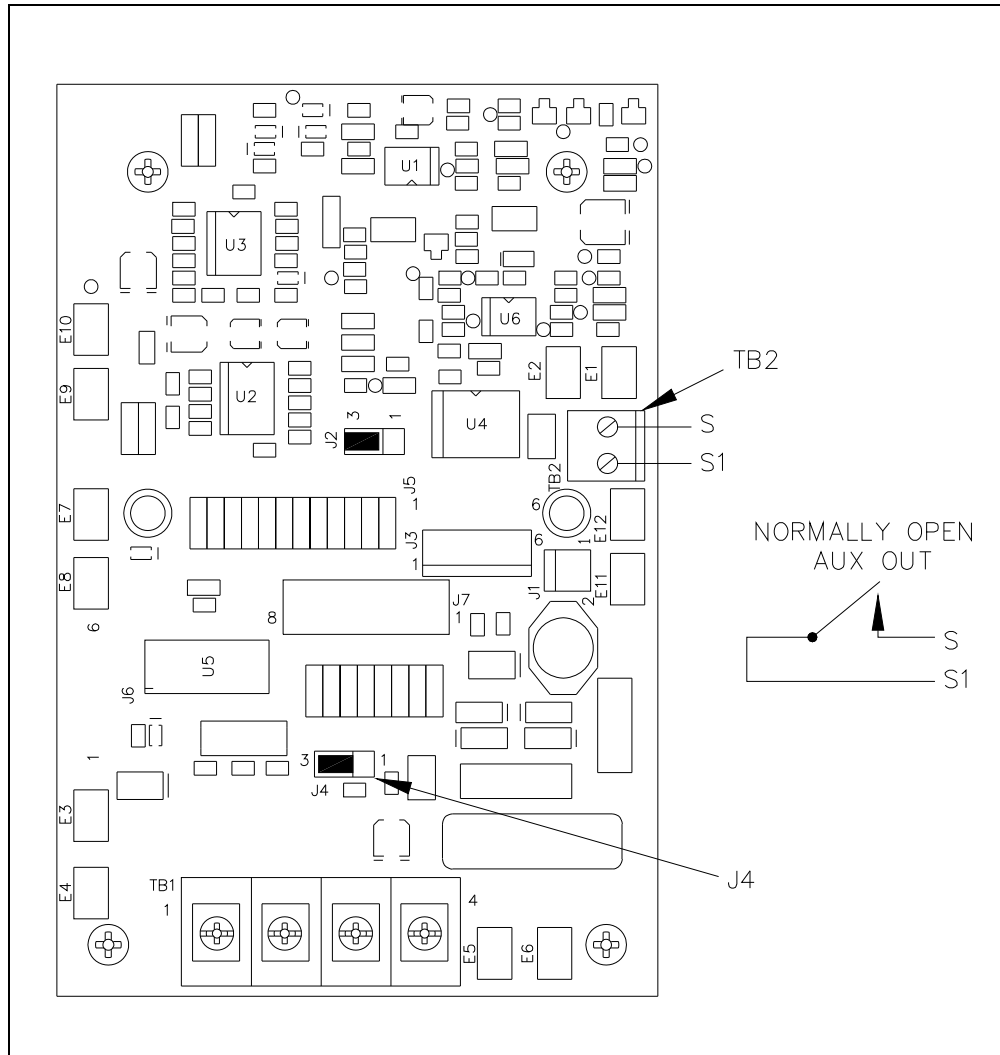

Figure 9. Industrial Telephone PCBA

Maintenance

Service

If your telephone requires service, contact your GAI-Tronics Regional Service Center for a return authorization number (RA#). Equipment should be shipped prepaid to GAI-Tronics with a return authorization number and a purchase order number. If the equipment is under warranty, repairs will be made without charge. Please include a written explanation of all defects to assist our technicians in their troubleshooting efforts.

Call 800-492-1212 inside the USA or 610-777-1374 outside the USA for help identifying the Regional Service Center closest to you.

Preventive Maintenance

Stainless steel does require maintenance to prevent corrosion from occurring. Different installation locations may require more regular maintenance than others, depending on the environment and exposure to airborne contaminants. The following maintenance steps should be performed on a regular basis or when corrosion is first noticed on your Model 210 Series Corridor Telephone.

Cleaning

- For general cleaning, wipe the surface with a cleanser or a cleanser and water mixture. Any cleanser that is safe for glass is usually safe for stainless steel. Wipe dry.
- If corrosion or rusting is noticed, remove with a non-abrasive commercial cleanser and water. Rub stained areas in the same direction as the existing grain. Stubborn stains may be removed with a magnesium oxide, ammonia, and water paste. Wipe clean with water rinse and dry.

Prevention

Automotive wax provides the best results in preventing corrosion on stainless steel. Simply apply wax, let dry to a haze, and buff to a shine with a clean dry cloth. This application should protect the telephone surface for many months as it will allow natural reformation of the chromium oxide layer.

Do NOT use steel wool, sandpaper, mineral acids, bleaches, or chlorine cleansers on the stainless surface.

Replacement Parts

Table 2. Available Replacement Parts

Part No.	Description
10113-020	Handset with 15-inch Armored Cord (Models 210-001BHAC/-003BHAC)
10113-021	Handset with 29-inch Armored Cord (Model 210-003)
10113-030	Handset with 12-inch Armored Cord (Models 210-001BH/-003BH)
10118-101	Handset assembly, 29-inch Armored Swivel Cord (Models 210-001/-002)
12512-012	Hookswitch Assembly Replacement Kit
51035-005A	Replacement Keypad (Models 210-001/-001BH/-001BHAC/-002)
61504-048	Keypad Cable Assembly (Models 210-001/-001BH/-001BHAC/-002)
13707-013	Replacement Ringer with Volume Control
12542-002	Security Screws (pack of 15)
69147-104	PCBA Replacement
233-001	Security Screwdriver

Specifications

Electrical

Frequency response.....	300–3,000 Hz
Inter-digit pause	100 ms
Minimum loop current	20 mA
Signaling tone (DTMF).....	100 ms tone duration
Supervisory dc current	minimum 20 mA dc; maximum 60 mA dc
Supervisory dc voltage.....	24–60 V dc (not polarity sensitive)
Network interface.....	loop start
Auxiliary output (isolated solid state switch)	48 V dc @ 125 mA 28 V ac _{RMS} @ 80 mA _{RMS}
Network signaling.....	DTMF
Handset receiver volume gain.....	+18 dB in 3 dB increments

Mechanical

Enclosure construction.....	16-gauge (0.060-inch) Type 304 brushed stainless steel
Dimensions	10.00 H × 5.50 W × 3.27 D in (254 × 139.7 × 83.1 mm)
Weight.....	5.5 lb (2.5 kg)
Handset/cord	
Models 210-001/-002.....	G-style with 29-inch armored swivel cord and volume pressbar switch
Model 210-003.....	G-style with 29-inch armored cord
Models 210-001BH/-003BH.....	G-style with 12-inch armored cord
Models 210-001BHAC/-003BHAC.....	G-style with 15-inch armored cord
Dial pad (Models 210-001/-001BH/-001BHAC/-002 only)	chrome-plated zinc

Environmental

Operating temperature	–40 °F to +140 °F (–40 °C to +60 °C)
Humidity	90% non-condensing

Approvals

Safety of Information Technology Equipment UL 60950 and CSA C22.2 No. 60950
Model 210-002 Only:
Class I, Division 2, Groups A, B, C, and D ANSI/ISA 12.12.01/CSA-C22.2 No. 157

FCC Information

FCC Registration Number US: ADGTE10A46048HAC
Ringer Equivalence Number (REN) 1.0A
Network Connection (USOC) RJ11
Meets hearing aid compatibility magnetic field intensity and volume control technical standards per FCC
Sections 68.316 and 68.317.

IC Information (Canada)

IC Certification Number IC: 822A-11754
Ringer Equivalence Number (REN) 1.0A
Connecting Method CA11A

User Instructions (USA)

This equipment has been tested and found to comply with the limits for a Class A digital device, pursuant to part 15 of the FCC Rules. These limits are designed to provide reasonable protection against harmful interference when the equipment is operated in a commercial environment. This equipment generates, uses, and can radiate radio frequency energy and, if not installed and used in accordance with the instruction manual, may cause harmful interference to radio communications. Operation of this equipment in a residential area is likely to cause harmful interference in which case the user will be required to correct the interference at his own expense.

This equipment complies with Part 68 of the FCC rules. Located on the equipment is a label that contains, among other information, the FCC registration number and ringer equivalence number (REN). If requested, this information must be provided to the telephone company. The REN is used to determine the quantity of devices which may be connected to the telephone line. Excessive REN's on the telephone line may result in the devices not ringing in response to an incoming call. In most, but not all areas, the sum of the REN's should not exceed five (5.0). To be certain of the number of devices that may be connected to the line, as determine by the total REN's contact the telephone company to determine the maximum REN for the calling area. This equipment cannot be used on the telephone company-provided coin service. Connection to Party Line Service is subject to State Tariffs. If this equipment causes harm to the telephone network, the telephone company will notify you in advance that temporary discontinuance of service may be required. If advance notice isn't practical, the telephone company will notify the customer as soon as possible. Also, you will be advised of your right to file a complaint with the FCC if you believe it is necessary. The telephone company may make changes in its facilities, equipment, operations, or procedures that could affect the operation of the equipment. If this happens, the telephone company will provide advance notice in order for you to make the necessary modifications in order to maintain uninterrupted service.

If trouble is experienced with this equipment, please contact:

GAI-Tronics Corporation
P.O. Box 1060
Reading, PA 19607-1060 USA
800-492-1212 or 610-777-1374

If the trouble is causing harm to the telephone network, the telephone company may request you to remove the equipment from the network until the problem is resolved. This equipment uses the following USOC jacks: RJ11C It is recommended that the customer install an ac surge arrester in the ac outlet to which this device is connected. This is to avoid damaging the equipment caused by local lightning strikes and other electrical surges. This equipment is Hearing-Aid Compatible (HAC). The telephone Consumer Protection Act of 1991 makes it unlawful for any person to use a computer or other electronic device, including fax machines, to send any message unless such message clearly contains in a margin at the top or bottom of each transmitted page or on the first page of the transmission, the date and time it is sent and an identification of the business or other entity, or other individual sending the message and the telephone number of the sending machine or such business, other entity, or individual. (The telephone number provided may not be a 900 number or any other number for which charges exceed local or long-distance transmission charges.)

User Instructions (Canada) CP-01, Issue 8, Part I: Section 14.1

NOTICE: The Industry Canada label identifies certified equipment. This certification means that the equipment meets certain telecommunications network protective, operational and safety requirements as prescribed in the appropriate Terminal Equipment Technical Requirements document (s). The Department does not guarantee the equipment will operate to the user's satisfaction. Before installing this equipment, users should ensure that it is permissible to be connected to the facilities of the local telecommunications company. The equipment must also be installed using an acceptable method of connection. The customer should be aware that compliance with the above conditions may not prevent degradation of service in some situations. Repairs to certified equipment should be coordinated by a representative designated by the supplier. Any repairs or alterations made by the user to this equipment, or equipment malfunctions, may give the telecommunications company cause to request the user to disconnect the equipment. Users should ensure for their own protection that the electrical ground connections of the power utility, telephone lines and internal metallic water pipe system, if present, are connected together. This precaution may be particularly important in rural areas.



Users should not attempt to make such connections themselves, but should contact the appropriate electric inspection authority, or electrician, as appropriate.

CP-01, Issue 8, Part I: Section 14.2

NOTICE: The **Ringer Equivalence Number** (REN) assigned to each terminal device provides an indication of the maximum number of terminals allowed to be connected to a telephone interface. The termination on an interface may consist of any combination of devices subject only to the requirement that the sum of the Ringer Equivalence Numbers of all the devices does not exceed 5.

Warranty

Equipment. GAI-Tronics warrants for a period of one (1) year from the date of shipment, that any GAI-Tronics equipment supplied hereunder shall be free of defects in material and workmanship, shall comply with the then-current product specifications and product literature, and if applicable, shall be fit for the purpose specified in the agreed-upon quotation or proposal document. If (a) Seller's goods prove to be defective in workmanship and/or material under normal and proper usage, or unfit for the purpose specified and agreed upon, and (b) Buyer's claim is made within the warranty period set forth above, Buyer may return such goods to GAI-Tronics' nearest depot repair facility, freight prepaid, at which time they will be repaired or replaced, at Seller's option, without charge to Buyer. Repair or replacement shall be Buyer's sole and exclusive remedy. The warranty period on any repaired or replacement equipment shall be the greater of the ninety (90) day repair warranty or one (1) year from the date the original equipment was shipped. In no event shall GAI-Tronics warranty obligations with respect to equipment exceed 100% of the total cost of the equipment supplied hereunder. Buyer may also be entitled to the manufacturer's warranty on any third-party goods supplied by GAI-Tronics hereunder. The applicability of any such third-party warranty will be determined by GAI-Tronics.

Services. Any services GAI-Tronics provides hereunder, whether directly or through subcontractors, shall be performed in accordance with the standard of care with which such services are normally provided in the industry. If the services fail to meet the applicable industry standard, GAI-Tronics will re-perform such services at no cost to buyer to correct said deficiency to Company's satisfaction provided any and all issues are identified prior to the demobilization of the Contractor's personnel from the work site. Re-performance of services shall be Buyer's sole and exclusive remedy, and in no event shall GAI-Tronics warranty obligations with respect to services exceed 100% of the total cost of the services provided hereunder.

Warranty Periods. Every claim by Buyer alleging a defect in the goods and/or services provided hereunder shall be deemed waived unless such claim is made in writing within the applicable warranty periods as set forth above. Provided, however, that if the defect complained of is latent and not discoverable within the above warranty periods, every claim arising on account of such latent defect shall be deemed waived unless it is made in writing within a reasonable time after such latent defect is or should have been discovered by Buyer.

Limitations / Exclusions. The warranties herein shall not apply to, and GAI-Tronics shall not be responsible for, any damage to the goods or failure of the services supplied hereunder, to the extent caused by Buyer's neglect, failure to follow operational and maintenance procedures provided with the equipment, or the use of technicians not specifically authorized by GAI-Tronics to maintain or service the equipment. **THE WARRANTIES AND REMEDIES CONTAINED HEREIN ARE IN LIEU OF AND EXCLUDE ALL OTHER WARRANTIES AND REMEDIES, WHETHER EXPRESS OR IMPLIED BY OPERATION OF LAW OR OTHERWISE, INCLUDING ANY WARRANTIES OF MERCHANTABILITY OR FITNESS FOR A PARTICULAR PURPOSE.**

Return Policy

If the equipment requires service, contact your Regional Service Center for a return authorization number (RA#). Equipment should be shipped prepaid to GAI-Tronics with a return authorization number and a purchase order number. If the equipment is under warranty, repairs or a replacement will be made in accordance with the warranty policy set forth above. Please include a written explanation of all defects to assist our technicians in their troubleshooting efforts.

Call 800-492-1212 (inside the USA) or 610-777-1374 (outside the USA) for help identifying the Regional Service Center closest to you.