



GAI-TRONICS®
A HUBBELL COMPANY

Division 1 Telephones

TABLE OF CONTENTS

<i>Confidentiality Notice</i>	<i>1</i>
<i>General Information</i>	<i>1</i>
<i>Hardware Description</i>	<i>1</i>
External.....	1
Internal	3
Ring Relay PCBA.....	3
<i>Installation</i>	<i>4</i>
Installation Guidelines.....	4
Front Cover Removal	5
Enclosure Mounting.....	5
Cable Entries	6
Wiring	6
Volume Control Jumper Setting.....	8
Auxiliary Output.....	8
Front Cover Installation.....	9
<i>Operation</i>	<i>10</i>
Models 352-001 and 352-002 Handset Operation	10
Models 352-003 and 352-004 Headset Operation.....	11
<i>Maintenance</i>	<i>12</i>
<i>Specifications</i>	<i>12</i>
Electrical (Typical).....	12
Environmental.....	12
Mechanical.....	12
<i>Approvals</i>	<i>13</i>
<i>User Instructions (USA)</i>	<i>13</i>



GAI-TRONICS®
A HUBBELL COMPANY

Division 1 Telephones

Confidentiality Notice

This installation, operation, and maintenance manual contains sensitive business and technical information that is confidential and proprietary to GAI-Tronics. GAI-Tronics retains all intellectual property and other rights in or to the information contained herein. Use this information only in connection with the operation of your GAI-Tronics product or system. Do not disclose this manual in any form, in whole or in part, directly or indirectly, to any third party.

General Information

GAI-Tronics' Class I, Division 1 telephones are constructed of cast aluminum and are weatherproof and corrosion resistant. The telephones operate as a standard analog telephone—simply lift the handset and dial the desired telephone number. The telephones are fully line powered and do not require external power for standard operation.

This manual applies to the following models:

- Model 352-001 Division 1 Telephone
- Model 352-002 Division 1 Telephone with Ring Relay
- Model 352-003 Division 1 Telephone with Headset
- Model 352-004 Division 1 Telephone with Ring Relay and Headset

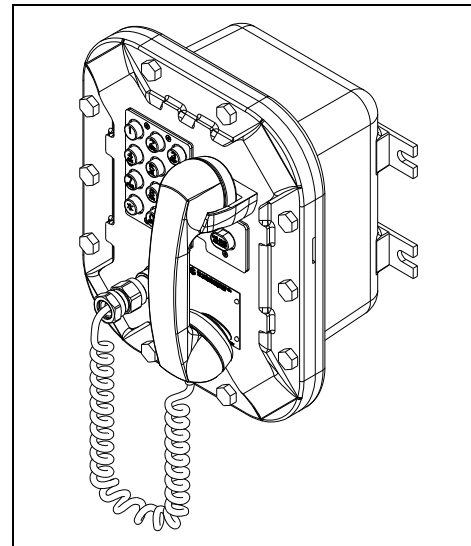

Figure 1. Model 352-001
Division 1 Telephone

Hardware Description

External

Models 352-001 and 352-002 each contain a handset with approved cable gland, standard keypad, volume control button, and applicable approval labeling. The handset rests on a cradle, which has a magnetic reed switch, behind it, to signal off-hook conditions. Ten cover mounting bolts, around the perimeter of the enclosure's flange, seal the enclosure (see Figure 2).

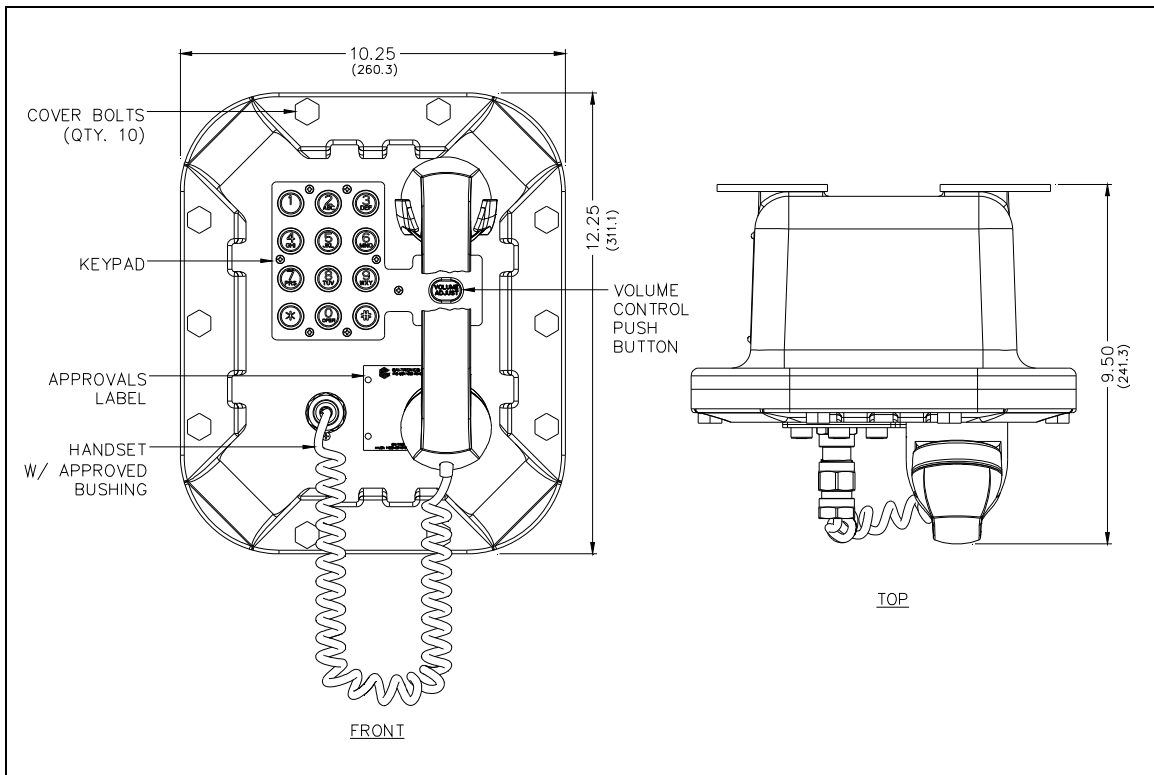

Figure 2. Model 352 Series Division 1 Telephone—Outline

For Models 352-003 and 352-004 with the headset option, the cradle and handset are replaced with a removable headset and headset activation bracket.

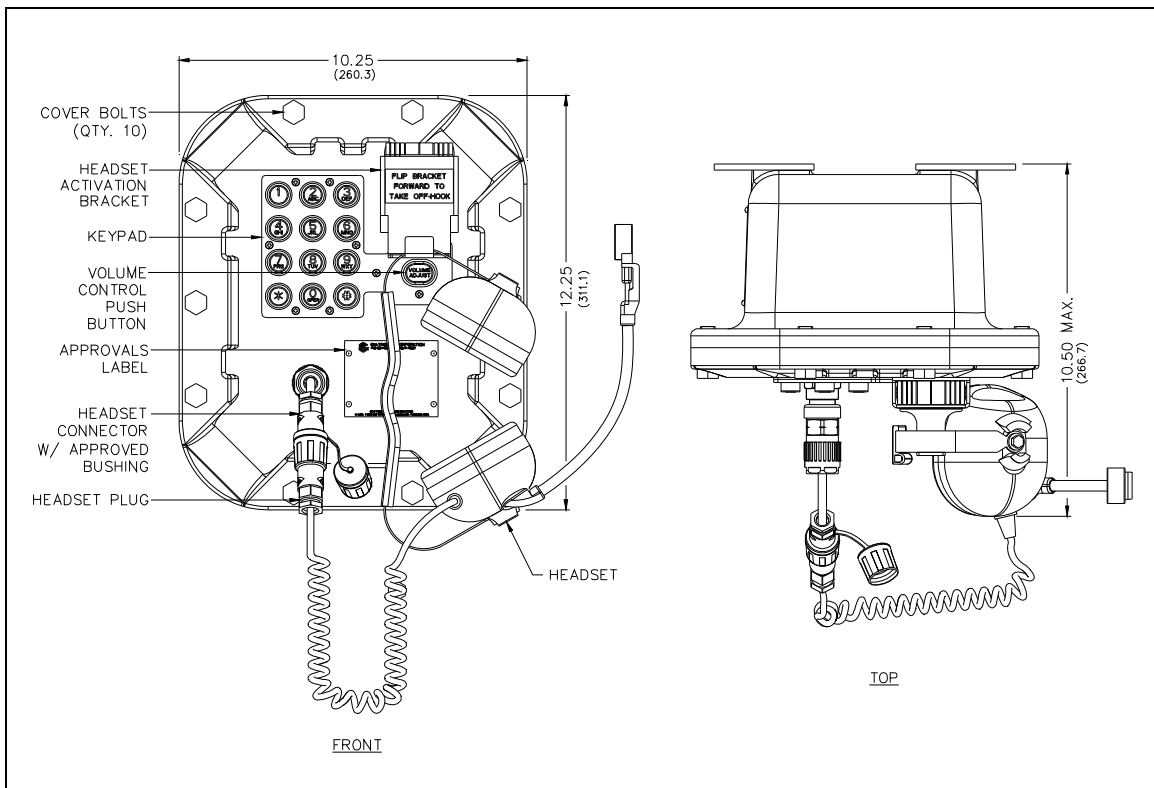

Figure 3. Model 352 Series Headset Models

Internal

All standard components mount to the rear of the front cover, except for the ring relay PCBA (*when installed*) (see [Figure 4](#)).

⚠ WARNING ⚠ —The front cover is not hinged to the rear enclosure. Adequately support the cover when removing the flange bolts.

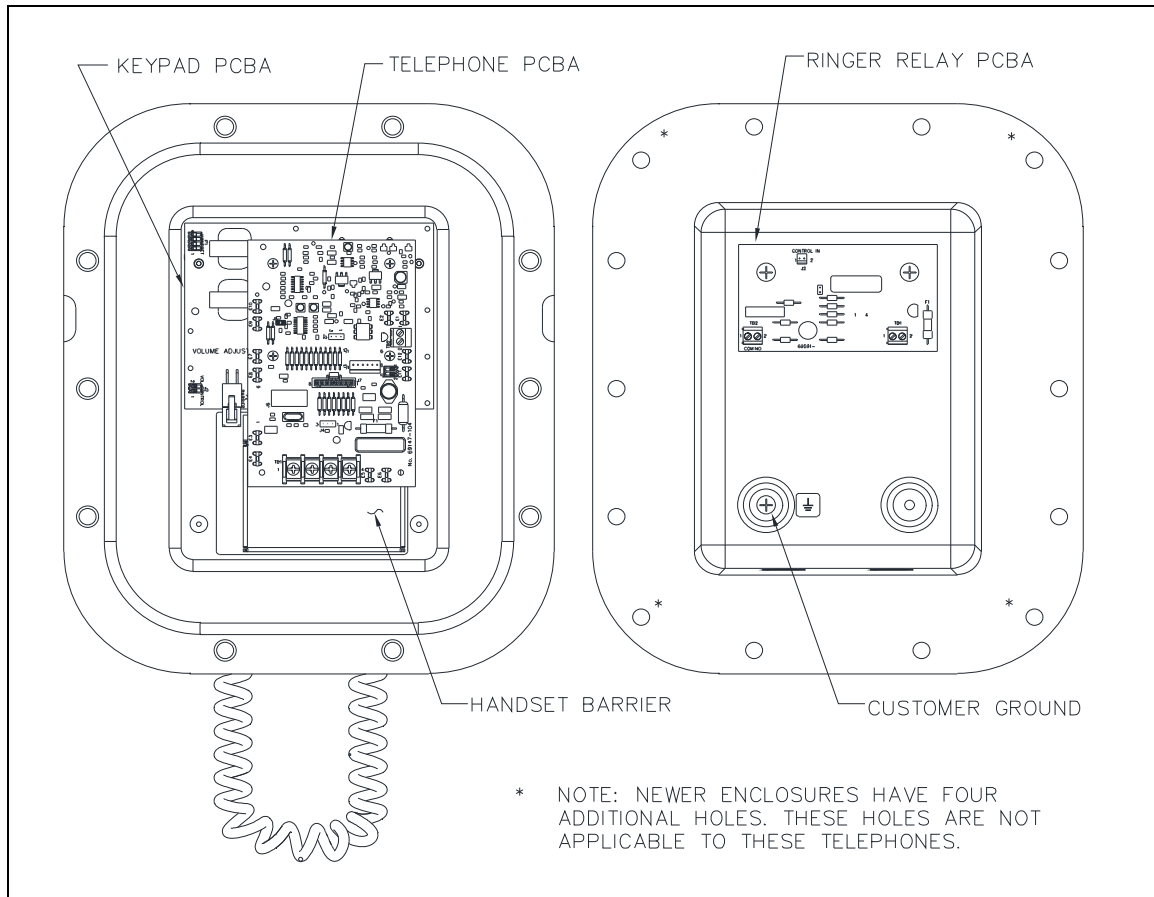

Figure 4. Model 352 Series Division 1 Telephone—Internal View



Ring Relay PCBA

The ring relay PCBA allows the telephone to activate an external beacon or sounder when the telephone receives a call. The ring relay PCBA connects to the main PCBA via a USOC RJ11C modular connector cord. This allows connection of the telephone's input wiring directly to the ring relay PCBA. The ring relay PCBA is in the rear enclosure (see [Figure 4](#) for mounting, and steps 4 through 6 in the [Wiring](#) section).



Installation

Installation Guidelines



Only trained, qualified, and competent personnel shall install these enclosures. Installation must comply with state and national regulations, as well as safety practices for this type of equipment.



 **CAUTION**  —**Do not install this equipment in hazardous areas other than those indicated in the Approvals section of this manual. Such installation may cause a safety hazard and consequent injury or property damage.**

The mounting location must be flat and provide proper clearance, rigidity, and strength to support the enclosure and all contained devices.

 **WARNING**  —Securely fasten the enclosure to the mounting location, using 3/8-inch diameter steel mounting bolts and washers, or washer head bolts.

 **WARNING**  —**Do not disconnect equipment while energized. Insure proper grounding to protective earthing.**

 **WARNING**  —The front cover is not hinged to the rear enclosure. Securely support the front cover while removing the cover bolts.

 **ATTENTION**  —Only qualified personnel shall install this equipment, which must be in accordance with the NEC (National Electrical Code) and/or applicable local codes.

Inspect and clean the machined flange flame joint surfaces of both the cover and box. Surfaces must be smooth, free of nicks, scratches, dirt, or any foreign particle build-up that would prevent a proper seal. Surfaces must seat fully against each other to provide a proper explosion-proof joint. Clean surfaces by wiping with a clean lint-free cloth.

Apply a light coating of Killark LUBG lubricant to the flange surfaces and close the cover. Install and tighten all cover bolts to ft·lb. Do NOT omit any cover bolts. Use only the bolts supplied with the enclosure.

Adhere to the following guidelines when installing GAI-Tronics telephone equipment to ensure the safety of all personnel:

- **Electrostatic Discharge (ESD) Protection:** These telephones have an earth ground terminal. Connect this terminal to earth ground in accordance with all local safety regulations and the NEC (National Electrical Code). Safe and stable communications require proper grounding. Do not use long and coiled ground wires.

NOTE: proper grounding does not eliminate the need for lightning protection for the telephone or the telephone system.

- NEVER install a telephone during a lightning storm.
- **Install a UL Listed lightning arrester** on any phone where the phone or phone cable is at risk of exposure to lightning strikes. Install the lightning arrester as close to the telephone as possible in a non-hazardous environment to maximize the protection. Do NOT install the lightning arrester within the telephone enclosure.

- NEVER touch uninsulated telephone wires or terminals unless the telephone line has been disconnected at the network interface.
- USE CAUTION when installing or modifying telephone lines.

Front Cover Removal

⚠ WARNING ⚠ —The front cover is not hinged to the rear enclosure. Adequately support the cover while removing the cover bolts.

1. Support the front cover and remove the ten cover bolts from the enclosure flange.
2. Pull the front cover far enough away to expose the internal connections.
3. Place the front cover aside.

Enclosure Mounting

NOTE: The mounting surface must be able to support the 28-pound weight of the telephone.

Securely fasten the enclosure to the mounting surface with 3/8-inch diameter steel mounting bolts on all four mounting feet.

- Stainless steel hardware is recommended for outdoor applications (see [Figure 5](#)).
- The suggested mounting height is 48 inches to the bottom of the enclosure.

NOTE: Refer to the Killark Installation, Operation, and Maintenance Data Sheet enclosed with the unit for additional enclosure information.

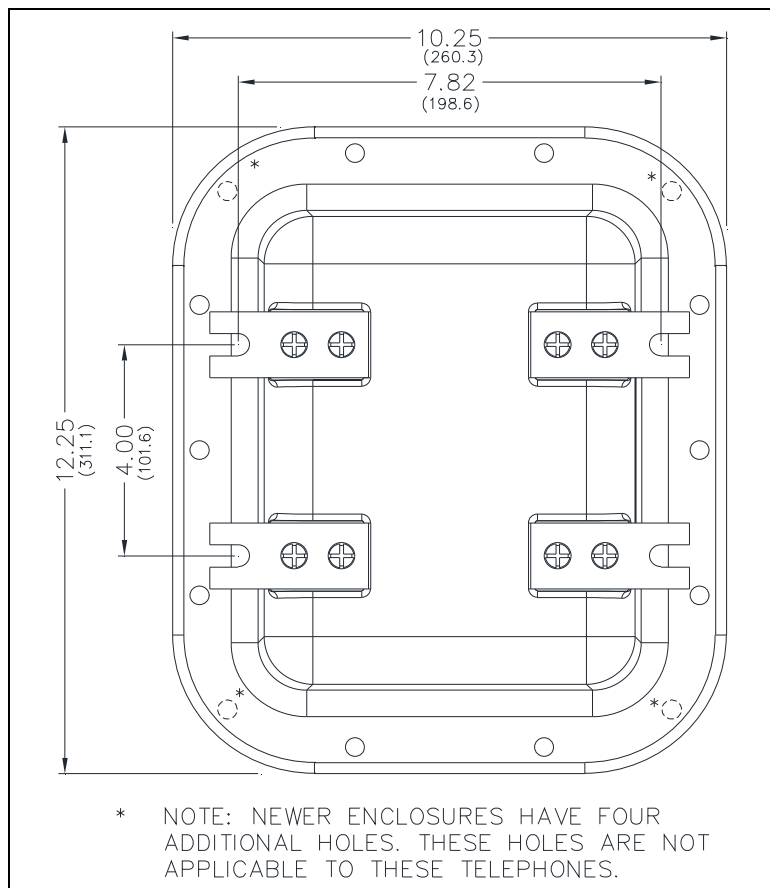

Figure 5. Model 352 Series Division 1 Telephone Enclosure—Mounting Details

Cable Entries

- Seal all unused openings with proper fittings per local standards.
- Use field wiring suitable for the ambient temperature.
- All conduit NPT plugs (blanking elements) must be explosion-proof with a Type 4X rating (see [Figure 6](#) for the NPT conduit entries).

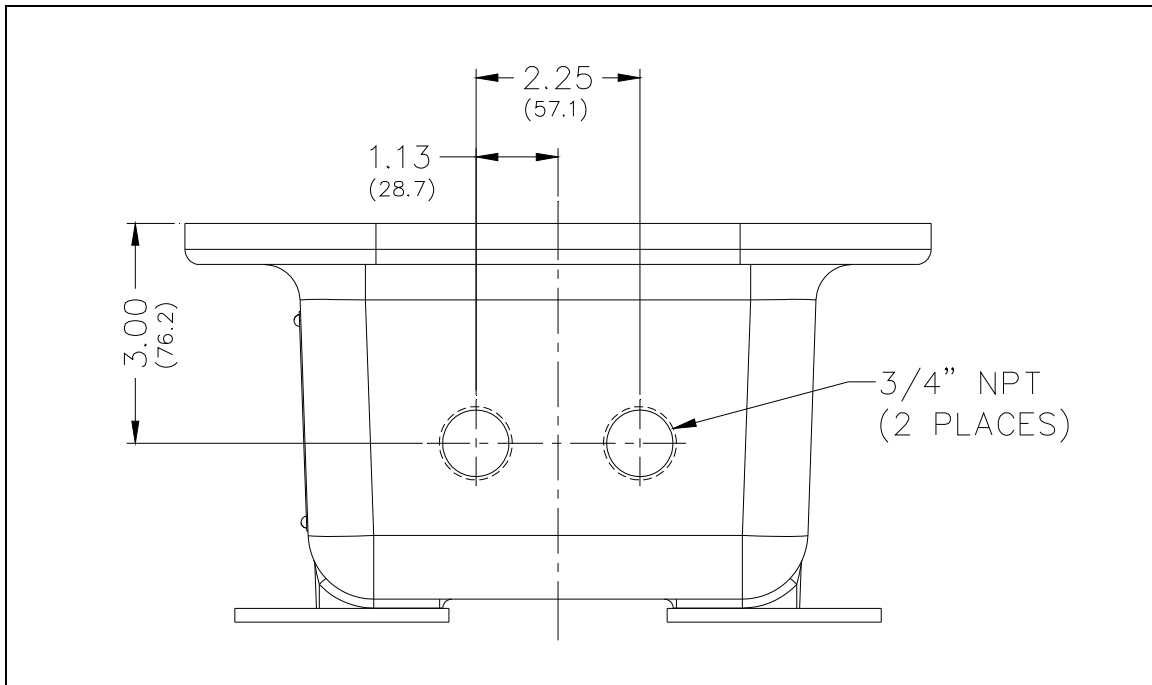

Figure 6. Model 352 Series Conduit Entries

Wiring

⚠ WARNING ⚠ —The front cover is not hinged to the rear enclosure. When the cover bolts are removed, the cover must be adequately supported.

1. While supporting the front cover, remove the ten cover bolts on the enclosure flange.
2. Pull the front cover far enough away to expose the internal connections and disconnect any wiring between the front cover and rear enclosure. Place the front cover aside.
3. Connect the incoming subscriber line or the telephone line suppressor (if applicable) to terminal block TB1 on the main PCBA when a ring relay PCBA is not present (see [Figure 7](#))

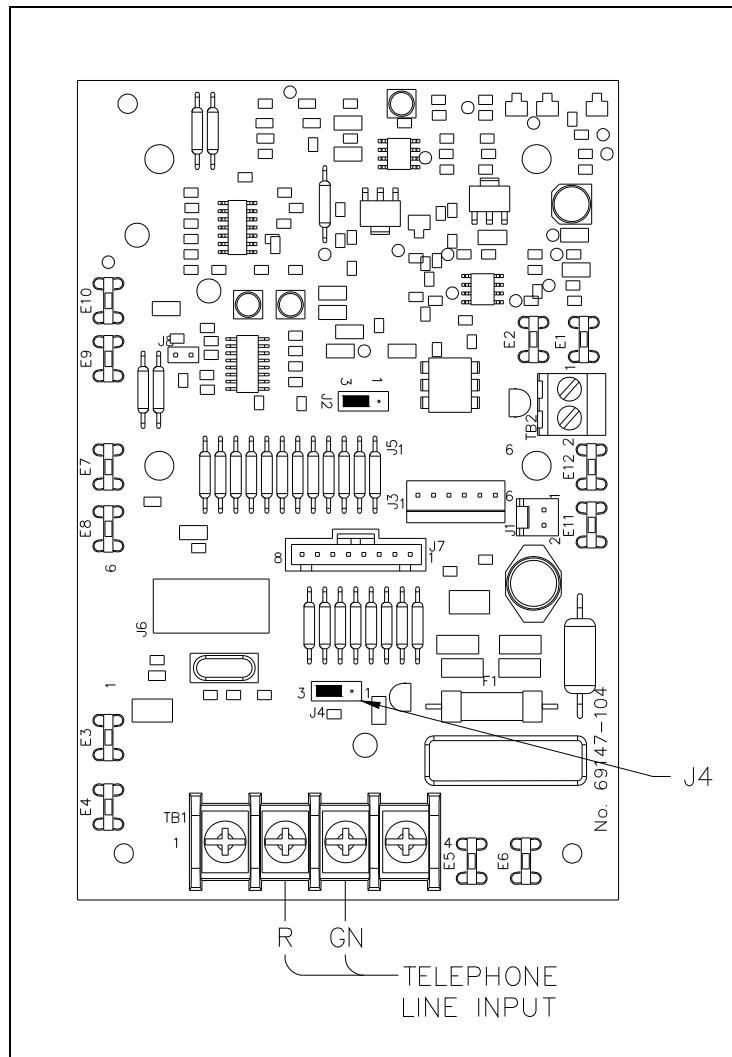

Figure 7. Main PCBA

4. When a ring relay PCBA is present, connect the incoming subscriber line to terminal block TB1, on the ring relay PCBA (see Figure 8 and Figure 9).

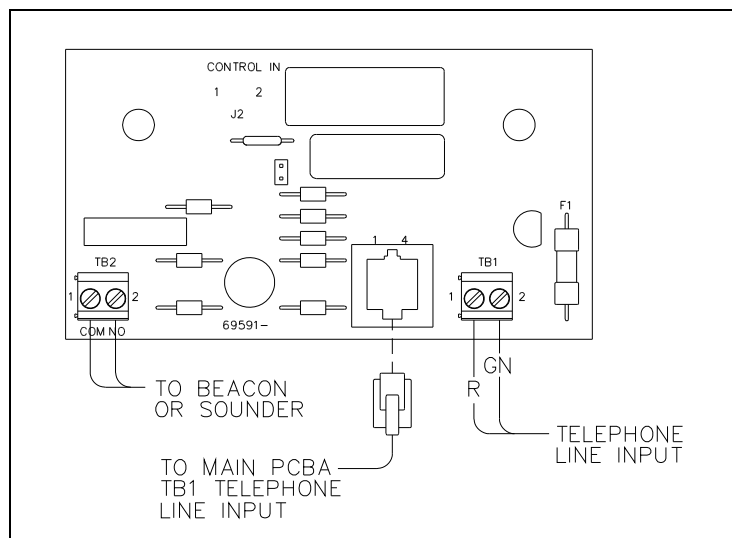

Figure 8. Ring Relay PCBA

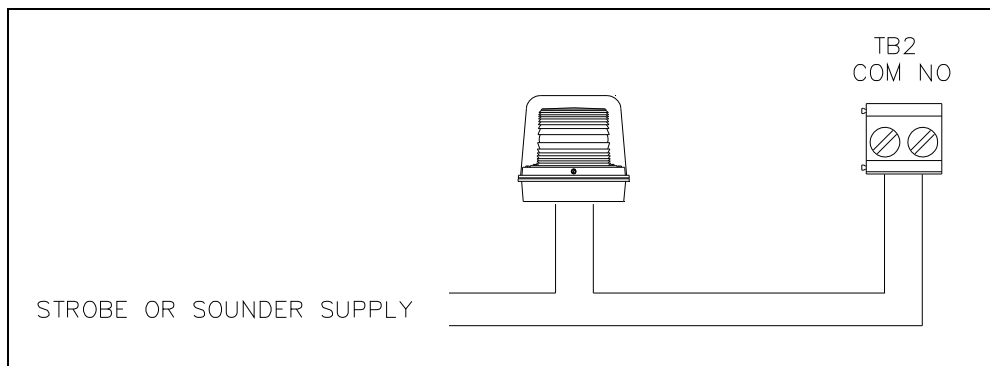

Figure 9. Strobe or Sounder Wiring

5. Connect the external sounder or beacon to terminal block TB2, for activation with an incoming telephone call.
6. Reconnect the USOC RJ11C modular connector cord from the main PCBA, on the front panel, to the ring relay PCBA, before reattaching the front cover.

⚠ WARNING ⚠ —Any external equipment connected to the ring relay PCBA must be rated for the hazardous area where it is located. Improper installation or equipment may cause a safety hazard and consequent injury or property damage.

Volume Control Jumper Setting

The handset receiver volume control is factory set to default to its original (0 dB) setting upon hanging up the telephone. To save the volume control setting, move jumper J4, which is factory set at positions 2 and 3, to positions 1 and 2 (see [Figure 7](#) for the location of jumper J4).

Auxiliary Output

Each telephone includes one isolated solid-state switch capable of switching a maximum of 48 V dc, 125 mA or 28 V_{RMS} ac, 80 mA_{RMS}. Terminal block TB2 (AUX OUT), on the main PCBA, provides the connections for the auxiliary output (see [Figure 10](#) for the location of terminal block TB2). This output remains energized for the duration of a call.

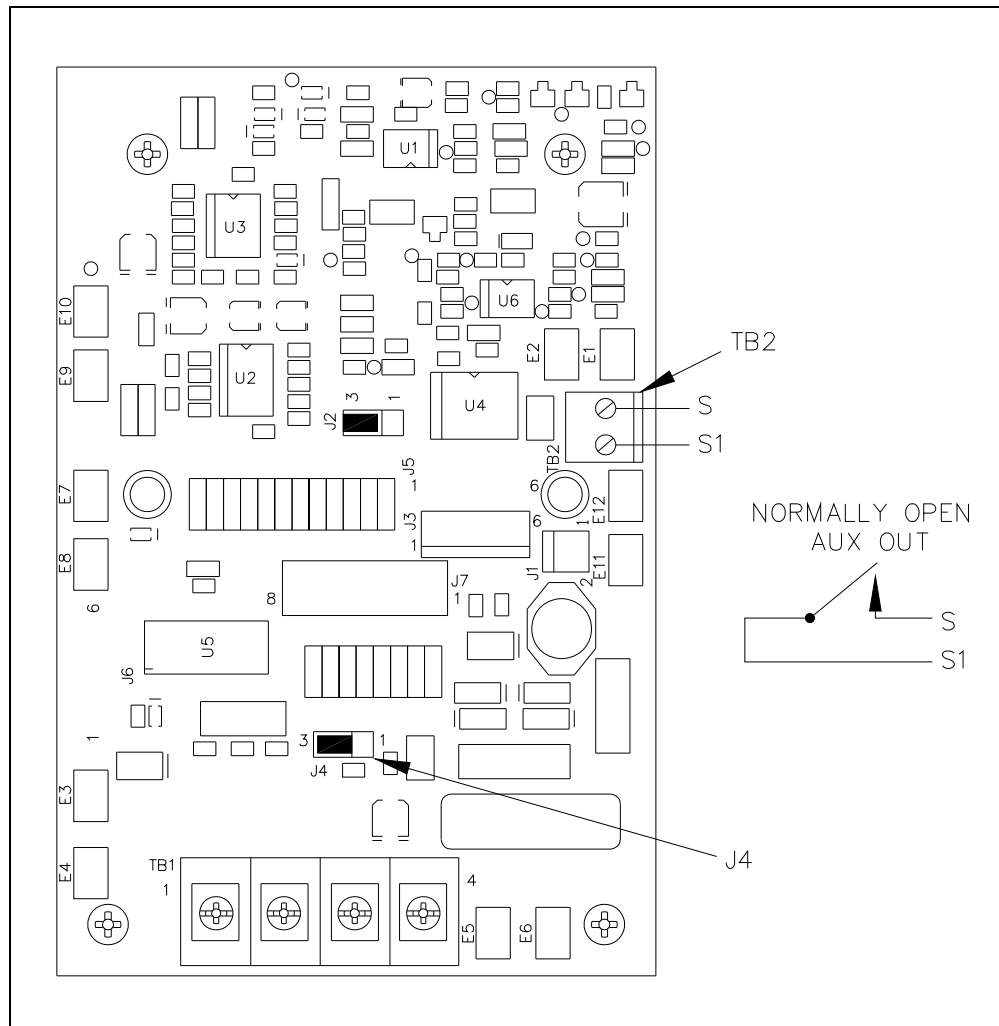

Figure 10. Main PCBA Volume Control Jumper and Auxiliary Output

Front Cover Installation

After completing all connections and adjustments, inspect and clean the machined flange joint surfaces of both the cover and box. Surfaces must be smooth, free of nicks, scratches, dirt, or any foreign particle build-up that may prevent a proper seal. Surfaces must seat fully against each other to provide a proper explosion-proof joint. Clean surfaces by wiping with a clean lint-free cloth.

Apply a light coat of Killark LUBG lubricant to flange surfaces and close the cover. Install and tighten all cover bolts to 30 ft-lb. Do **NOT** omit any cover bolts. Use only the bolts supplied with the enclosure.

NOTE: Refer to the Killark Installation, Operation, and Maintenance Data Sheet enclosed with the unit for additional enclosure information.

Operation

Models 352-001 and 352-002 Handset Operation

1. Lift the handset to place a call.
2. The handset receiver volume located on the front cover keypad, can be adjusted to the desired level by pressing the volume control push button.

NOTE: Pressing the volume control push button increases the volume in 3-dB increments. The volume starts at 0 dB and increases to a maximum volume of 18 dB. Pressing the volume control push button a seventh time returns the volume to 0 dB.

3. Dial the desired number.
4. After completion of the call, place the handset on-hook.

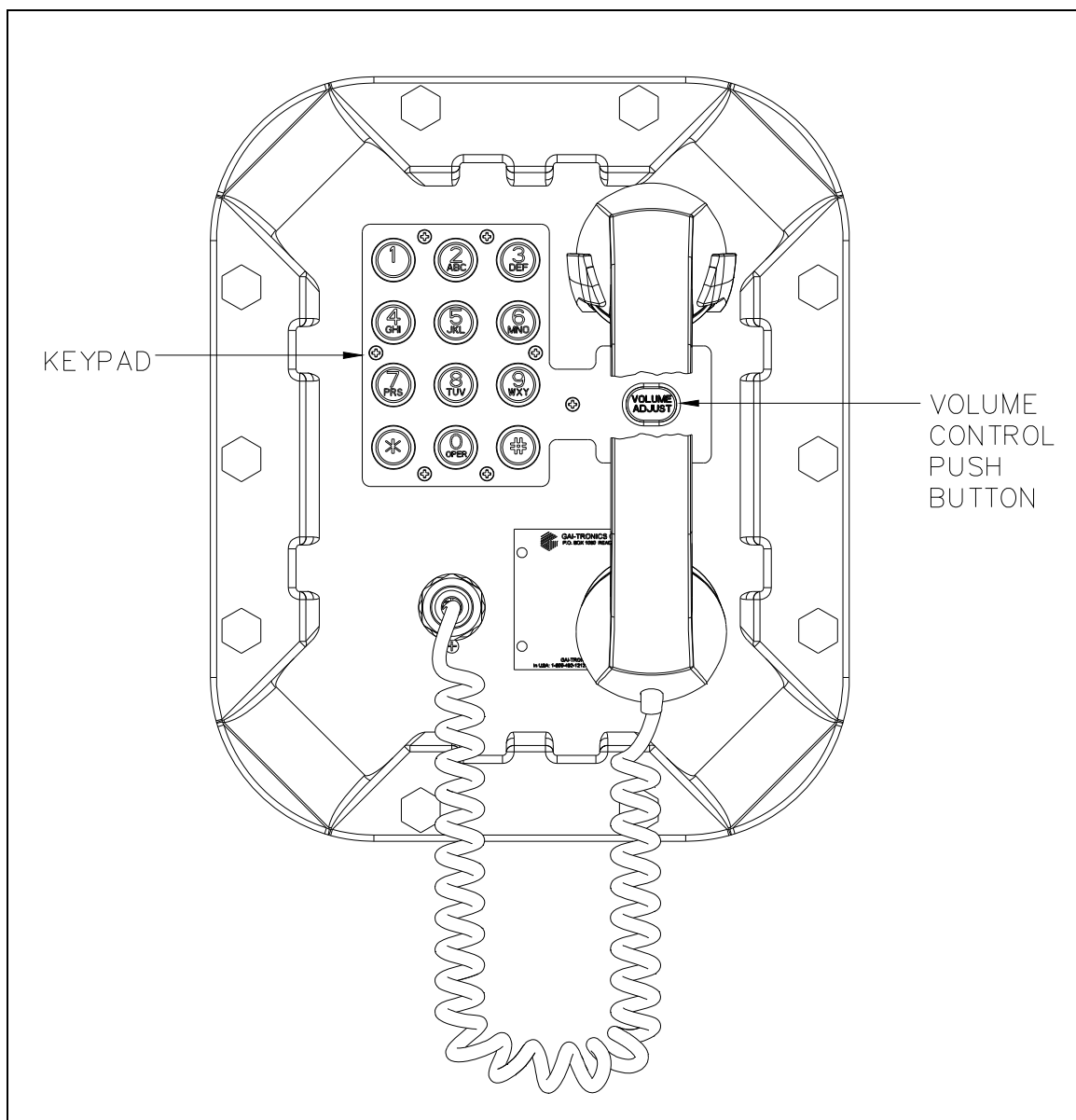

Figure 11. Models 352-001 and 352-002

Models 352-003 and 352-004 Headset Operation

1. To connect the headset, plug it into the flexible plug on the front of the telephone by removing the sealing cap from the receptacle, aligning the connector pins, and screwing the two ends together.

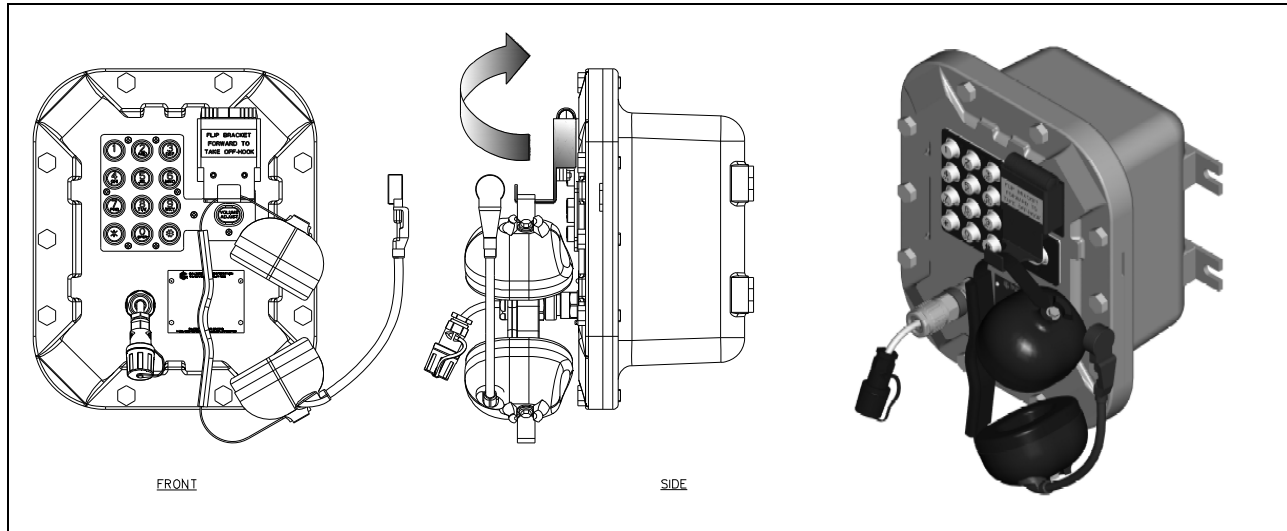

Figure 12. Models 352-003 and 352-004

2. To place a call, remove the headset from the headset activation bracket and flip the headset bracket forward to its preset position (see [Figure 12](#)).
3. The handset receiver volume control, which is located on the front cover keypad, can be adjusted to the desired level by pressing the volume control push button.

NOTE: Pressing the volume control push button increases the volume in 3-dB increments. The volume starts at 0 dB and increases to a maximum volume of 18 dB. Pressing the volume control push button a seventh time will return the volume to 0 dB.

4. Dial the desired number.
5. Flip the headset activation bracket to its vertical preset position to hang up. If applicable, place the headset on the bracket after completing the call. Otherwise, disconnect the flexible receptacle and plug by unscrewing the two ends, and pulling them apart. When disconnected, reattach the sealing cap to the end of the receptacle (see [Figure 13](#)).

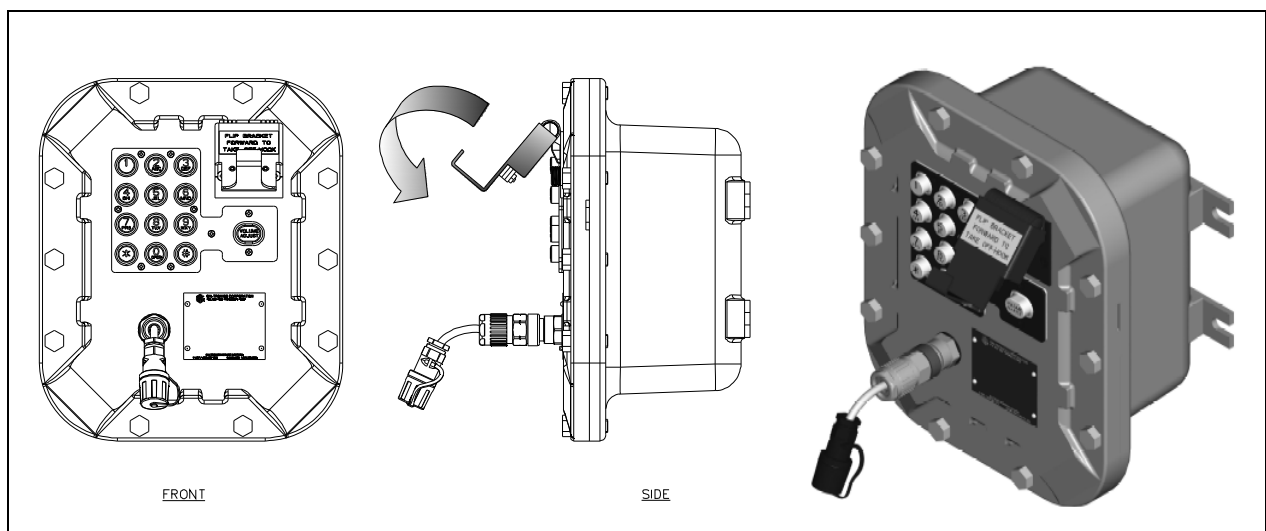

Figure 13. Models 352-003 and 352-004—Headset Disconnection

Maintenance

Contact a regional service center for a return authorization number (RA#) if the equipment requires service. Ship equipment prepaid to GAI-Tronics with an RA# and a purchase order number. GAI-Tronics makes repairs or provides replacement in accordance with our warranty policy if the equipment is under warranty. Please include a written explanation of all the defects to assist our technicians in their troubleshooting efforts.

Call 800-492-1212 inside the USA or 610-777-1374 outside the USA for help with identifying the closest Regional Service Center.

Specifications

Electrical (Typical)

Frequency response.....	300–3,000 Hz
Inter-digit pause	100 ms
Minimum loop current	20 mA
Signaling tone (DTMF).....	100 ms tone duration
Supervisory dc current	minimum 20 mA dc; maximum 60 mA dc
Supervisory dc voltage.....	24–60 V dc (not polarity sensitive)
Network interface.....	loop start
Auxiliary output (isolated solid-state switch)	48 V dc @ 125 mA 28 V _{RMS} ac @ 80 mA _{RMS}
Ring Relay PCBA output mechanical relay contact	250 V ac @ 5A 30 V dc @ 5A
Network signaling	DTMF
REN (Ringer Equivalence Number) <u>with</u> ringer relay PCBA	3.1A
REN <u>without</u> Ringer Relay PCBA	1.0A/1.3B

Environmental

Operating temperature	–40 °F to +140 °F (–40 °C to +60 °C)
Humidity	90% non-condensing

Mechanical

Enclosure	cast aluminum with aluminized lacquer paint
Handset Cord	G-style handset/PVC 6-foot extended length (standard)
Connections.....	internal screw-type barrier terminal blocks
Dimensions, outside.....	10.25 W × 12.25 H × 9.50 D in (260.3 × 311.1 × 241.3 mm)
Mounting.....	wall or column, four 3/8-inch (10 mm) mounting feet with slots
Shipping weight	30.0 lb (13.6 kg)
Net weight.....	28.0 lb (12.7 kg)

Approvals

NRTL listed Hazardous locations Class I, Division 1, Groups B, C, & D
(USA and Canada)..... Class II, Division 1, Groups F & G
Class III, Division 1
T6—Gas
T4A—Dust

User Instructions (USA)

This equipment has been tested and found to comply with the limits for a Class A digital device, pursuant to part 15 of the FCC Rules. These limits are designed to provide reasonable protection against harmful interference when the equipment is operated in a commercial environment. This equipment generates, uses, and can radiate radio frequency energy and, if not installed and used in accordance with the instruction manual, may cause harmful interference to radio communications. Operation of this equipment in a residential area is likely to cause harmful interference in which case the user will be required to correct the interference at his own expense.

Warranty

Equipment. GAI-Tronics warrants for a period of one (1) year from the date of shipment, that any GAI-Tronics equipment supplied hereunder shall be free of defects in material and workmanship, shall comply with the then-current product specifications and product literature, and if applicable, shall be fit for the purpose specified in the agreed-upon quotation or proposal document. If (a) Seller's goods prove to be defective in workmanship and/or material under normal and proper usage, or unfit for the purpose specified and agreed upon, and (b) Buyer's claim is made within the warranty period set forth above, Buyer may return such goods to GAI-Tronics' nearest depot repair facility, freight prepaid, at which time they will be repaired or replaced, at Seller's option, without charge to Buyer. Repair or replacement shall be Buyer's sole and exclusive remedy. The warranty period on any repaired or replacement equipment shall be the greater of the ninety (90) day repair warranty or one (1) year from the date the original equipment was shipped. In no event shall GAI-Tronics warranty obligations with respect to equipment exceed 100% of the total cost of the equipment supplied hereunder. Buyer may also be entitled to the manufacturer's warranty on any third-party goods supplied by GAI-Tronics hereunder. The applicability of any such third-party warranty will be determined by GAI-Tronics.

Services. Any services GAI-Tronics provides hereunder, whether directly or through subcontractors, shall be performed in accordance with the standard of care with which such services are normally provided in the industry. If the services fail to meet the applicable industry standard, GAI-Tronics will re-perform such services at no cost to buyer to correct said deficiency to Company's satisfaction provided any and all issues are identified prior to the demobilization of the Contractor's personnel from the work site. Re-performance of services shall be Buyer's sole and exclusive remedy, and in no event shall GAI-Tronics warranty obligations with respect to services exceed 100% of the total cost of the services provided hereunder.

Warranty Periods. Every claim by Buyer alleging a defect in the goods and/or services provided hereunder shall be deemed waived unless such claim is made in writing within the applicable warranty periods as set forth above. Provided, however, that if the defect complained of is latent and not discoverable within the above warranty periods, every claim arising on account of such latent defect shall be deemed waived unless it is made in writing within a reasonable time after such latent defect is or should have been discovered by Buyer.

Limitations / Exclusions. The warranties herein shall not apply to, and GAI-Tronics shall not be responsible for, any damage to the goods or failure of the services supplied hereunder, to the extent caused by Buyer's neglect, failure to follow operational and maintenance procedures provided with the equipment, or the use of technicians not specifically authorized by GAI-Tronics to maintain or service the equipment. **THE WARRANTIES AND REMEDIES CONTAINED HEREIN ARE IN LIEU OF AND EXCLUDE ALL OTHER WARRANTIES AND REMEDIES, WHETHER EXPRESS OR IMPLIED BY OPERATION OF LAW OR OTHERWISE, INCLUDING ANY WARRANTIES OF MERCHANTABILITY OR FITNESS FOR A PARTICULAR PURPOSE.**

Return Policy

If the equipment requires service, contact your Regional Service Center for a return authorization number (RA#). Equipment should be shipped prepaid to GAI-Tronics with a return authorization number and a purchase order number. If the equipment is under warranty, repairs or a replacement will be made in accordance with the warranty policy set forth above. Please include a written explanation of all defects to assist our technicians in their troubleshooting efforts.

Call 800-492-1212 (inside the USA) or 610-777-1374 (outside the USA) for help identifying the Regional Service Center closest to you.