



GAI-TRONICS®
A HUBBELL COMPANY

RED ALERT®

Auto-Dial Telephone Manual

TABLE OF CONTENTS

<i>Confidentiality Notice</i>	1
<i>Product Overview</i>	1
Telephones	1
Telephone Management Application (TMA)	3
<i>Standard Operation</i>	3
Receiving a Call.....	3
Disconnecting a Call	4
Location Identification Code Dialing	4
<i>Installation</i>	4
Safety Guidelines.....	4
General Installation Guidelines	5
Security Hardware.....	5
Conduit Installation Details (Surface Mount Applications).....	5
Models 393-00xAD and 393AL-00xAD	7
Model 397-00xAD (Stanchion or Flush-Mount Applications)	9
Model 397-001ADFS (Flush-Mount Applications)	12
External Power for -003AD Models	14
GAI-Tronics Strobe Connection.....	15
<i>Setup</i>	16
Hardware Configuration	16
Auto-answer Configuration	16
Polarity Configuration	16
DTMF Gain Select Configuration.....	16
Password Enable Configuration.....	17
Command Select Configuration.....	17
Low-Power Mode Configuration	17
Hardware Settings.....	17
Auxiliary Outputs	18
Extreme Cold Temperature Option	19
Auxiliary Output Control	19

Standard Mode Programming	21
Set-up Sequence	21
Remote	21
Local	21
Programming Sequence	21
Password Disabled Programming	22
Programming Information	23
Dialing Options.....	23
Password Protection.....	25
Auto-Answer Alert Feature.....	25
Disconnect Options	26
Americans with Disabilities Act (ADA) Programming	27
Extended Strobe Operation (Requires External Power Supply).....	27
Output 4 Control Setup	28
Early Microphone Option	29
SMART Mode Programming	31
Maintenance	31
Service	31
Preventive Maintenance for Models 397-001AD, 397-001ADFS, and 397-003AD	31
Cleaning	31
Corrosion Prevention	31
Replacement Parts	32
Specifications	32



GAI-TRONICS®
A HUBBELL COMPANY

RED ALERT®

Auto-Dial Telephone Manual

Confidentiality Notice

This manual is provided solely as an installation, operation, and maintenance guide, which contains sensitive business and technical information that is confidential and proprietary to GAI-Tronics. GAI-Tronics retains all intellectual property and other rights in or to the information contained herein, and such information may only be used in connection with the operation of your GAI-Tronics product or system. This manual may not be disclosed in any form, in whole or in part, directly or indirectly, to any third party.

Product Overview

Telephones

RED ALERT® series Auto-dial (AD series) telephones have been designed for maximum environmental sustainability and high audio quality. The AD series telephones provide reliable, hands-free, two-way communications in nearly any environment as all models are rated Type 3R. The AD series products are intended for a single-button call activation telephone in a non-emergency environment.

Each AD series telephone complies with the Americans with Disabilities Act (ADA) in both physical and operational characteristics. Each telephone includes a Braille label for vision-impaired individuals for identifying the “call” function of the telephone and a visual CALL RECEIVED WHEN LIT LED for hearing-impaired individuals. The LED will flash when the CALL button is pressed (call in progress) and will provide a steady illumination when the call has been answered. The LED remains illuminated until the call is terminated.

The CALL button on each telephone can be programmed to dial three different telephone numbers. These include a primary telephone number and two “rollover” telephone numbers. In the event that the first number goes unanswered or is busy, the telephone will automatically dial the first rollover number. The second rollover number will be dialed if the first rollover number cannot connect. This feature is completely programmable.

All RED ALERT® Auto-dial series telephones are line-powered and can be connected to any of the following networks:

- Central Office (C.O.) line to the Public Switched Telephone Network (PSTN)
- 24 V dc or 48 V dc analog station port of a Private Branch Exchange (PBX), Private Automatic Branch Exchange (PABX), or Key Service Unit (KSU).

NOTE: Connection to pay telephone extensions or shared service (party) lines should be avoided.

Each telephone requires a minimum line current of 24 mA for proper operation. For operation below -4 °F (-20 °C), GAI-Tronics offers an Extreme Cold Weather Option that includes a plug-in power supply (120 V ac required) and a non-tactile CALL push button. This option will allow reliable operation to -40 °F (-40 °C).

The RED ALERT® Auto-dial series telephones provide the flexibility to address a diverse range of applications. A wide variety of functions can be achieved by altering the configuration data stored in the telephone's non-volatile memory. These configuration options include:

- Pre-programmed auto-dial telephone numbers
- Call termination method (automatic or manual)
- Maximum call duration
- Answering options

Values for these functions are initially programmed during factory testing, but can be changed remotely from a touch-tone telephone.

The following RED ALERT® Auto-dial Telephone models are detailed in this manual:

Table 1. Model Chart

Model	Description
393-001AD	Surface-Mount Telephone , single auto-dial push button, weatherproof glass-reinforced polyester enclosure, safety yellow.
393-003AD	Surface-Mount Telephone , single auto-dial push button, weatherproof glass-reinforced polyester enclosure, safety yellow, Extreme Cold Weather option.
393AL-001AD	Surface-Mount Telephone , single auto-dial push button, weatherproof cast aluminum enclosure, safety yellow.
393AL-003AD	Surface-Mount Telephone , single auto-dial push button, weatherproof cast aluminum enclosure, safety yellow, Extreme Cold Weather option.
397-001AD	Flush-Mount Telephone , single auto-dial push button, weatherproof brushed stainless steel front panel.
397-001ADFS	Flush-Mount Compact Telephone , single auto-dial push button, weatherproof brushed stainless steel front panel. This telephone is functionally identical to Model 397-001AD.
397-003AD	Flush-Mount Telephone , single auto-dial push button, weatherproof brushed stainless steel front panel, Extreme Cold Weather option.

Telephone Management Application (TMA)

RED ALERT® Auto-dial series Telephones are also compatible with GAI-Tronics Telephone Management Application (TMA) software package (purchased separately). TMA is a maintenance data collection tool that allows users to view and report the health and activity of the AD telephones. The decision to use TMA can be made at any time and it is not needed for telephone operation. Installation of TMA is not required unless system monitoring is desired.

When used with TMA, each telephone will typically be polled on a scheduled basis to determine its health and will report the following:

- Stuck push button
- Microphone failure
- Speaker failure
- Microprocessor health (handshake)
- Line interrupt (line current loss)

A dedicated telephone line is required per auto-dial telephone when the typical “polling” operation is used. Although not recommended, auto-dial telephones can share a telephone line with the understanding that if two or more telephones are put into use simultaneously, the line current could drop sufficiently to disconnect the telephone call completely. This will depend on the line current, the length of the cable run, and the condition of the telephone cable. When sharing a telephone line using TMA, the telephone must be scheduled to “call in” instead of being polled by TMA.

The basic TMA package, Model 12509-042, includes a single line transceiver for polling a single telephone at a time (dedicated telephone line required). A TMA expansion kit (Model 12509-043) introduces an additional transceiver to the system for multiple simultaneous telephone polling. The system will support up to eight transceivers. A dedicated telephone line is required for each transceiver.

Standard Operation

1. Press the CALL push button to place an immediate call to a pre-programmed telephone number.
2. The CALL RECEIVED WHEN LIT indicator (LED) operates as follows:
 - The indicator will begin to flash when the CALL push button is pressed (call in progress) and will illuminate steadily when the telephone detects audio after the call is answered.
 - or -
 - The indicator will begin to flash when the CALL push button (call in progress) is pressed and will illuminate steadily when the called party acknowledges receiving the call by transmitting a DTMF “#” or “*” after answering the call.
3. Two-way, hands-free conversation can now occur.

Receiving a Call

Each RED ALERT® Telephone can be programmed to auto-answer an incoming call. When the auto-dial telephone extension is dialed, the unit will automatically answer, generate a pair of triple “beep” tones, and two-way, hands-free conversation can occur.

Disconnecting a Call

There are several methods by which a RED ALERT® Auto-dial Telephone can both manually and automatically disconnect calls. The disconnect methods include the following:

- **Remote disconnect of a call** – Called party transmits either a “##” or “*99” DTMF control command.
- **Manual disconnect of a call** – Press the CALL push button approximately 15 seconds after the initial activation.

NOTE: Pressing the CALL push button a second time within 10 seconds of initially activating the call will have no effect on the telephone’s operation. This prevents an anxious or hurried user from disconnecting the call prematurely (this feature can be disabled).

- **Automatic disconnect:**
 - All calls; loop current-drop disconnect
 - All calls; maximum call duration timeout (configurable from 1 minute to 4.5 hours)
 - All voice calls; call progress tones (i.e., busy /fast busy tone) and, when enabled, dial tone.



Refer to the “Programming” section of this manual for factory defaults and available options.

Location Identification Code Dialing

The location identification code feature enables the called party to quickly and easily locate the source of the auto-dial call. When the calling individual presses the CALL push button, the called party (typically the security operator) presses the “*” button on their telephone. The AD Telephone detects the “*” signal and transmits a three-digit, DTMF, location identification code. This location code can be displayed on a customer-provided DTMF decoder/display.

Please refer to the “Americans with Disabilities Act (ADA) Programming” section on Page 27.

Installation

 **ATTENTION**  Installation should be performed by qualified personnel and only in accordance with the National Electrical Code or applicable local codes.

Safety Guidelines

When installing any GAI-Tronics telephone equipment, please adhere to the following guidelines to ensure the safety of all personnel:

- Do not install telephone wiring during a lightning storm.
- **Electrostatic Discharge (ESD) Protection:** Your telephone may have an earth ground terminal provision. If so, ensure that it is connected to ground in accordance with all local safety regulations and the National Electrical Code (NEC). Grounding has to be ensured for safe and stable communications. Do not use long and coiled ground wires. Trim ground wires to the required length. Use a star configuration whenever possible. Please note proper grounding does not eliminate the need for lightning protection for the telephone or the telephone system.
- **Install a UL Listed lightning arrester** on any telephone installed where the telephone or telephone cable is at risk of being exposed to lightning strikes. The lightning arrester must be installed as close to the telephone as possible to maximize the protection. It must not be installed within the enclosure supplied with the telephone.

- Do not install telephone jacks in wet locations unless the jack is specifically designed for wet locations.
- Do not touch uninsulated telephone wires or terminals unless the telephone line has been disconnected at the network interface.

General Installation Guidelines

As previously noted, the preferred system configuration is a dedicated telephone line for each RED ALERT® Telephone. This is an actual **requirement** when using TMA in its typical “polling” operation.

Although it is not recommended, a RED ALERT® Telephone can share a telephone line with another RED ALERT® Telephone with the understanding that if two or more telephones are put into use simultaneously the line current could drop sufficiently to disconnect the telephone call completely. Additional “line sharing” or “party line” configuration issues could include sporadic telephone operation, difficulties with programming, or premature disconnection of calls. Special system features (voice mail, call waiting, etc.) could also create problems if not disabled. Successful shared line operation will depend on the line current, the length of the cable run, and the condition of the telephone cable.

NOTE: A RED ALERT® Telephone should never be installed on the same telephone line as any other (non-RED ALERT®) telephone type.

When sharing a telephone line using TMA, the telephone must be scheduled to “call-in” instead of being polled by TMA.

Security Hardware

All of the telephones described in this manual are vandal resistant. The front panel for each telephone covered in this manual is attached to its enclosure with security screws. A GAI-Tronics Model 233-001 Security Screwdriver or Torx T-25 security head tip (sold separately) is required for installing the telephone.

Conduit Installation Details (Surface Mount Applications)

GAI-Tronics recommends installing telephone lines in conduit to protect against accidental damage and vandalism. To prevent moisture from entering the enclosure, we strongly recommend the following:

- Conduit should enter the enclosure from the bottom whenever possible.
- Sealed fittings should be installed at all cable entry points.
- Silicone sealant or equivalent should be applied around and inside all conduit entries to prevent moisture ingress.

Please refer to the examples below for the recommended conduit installation details.

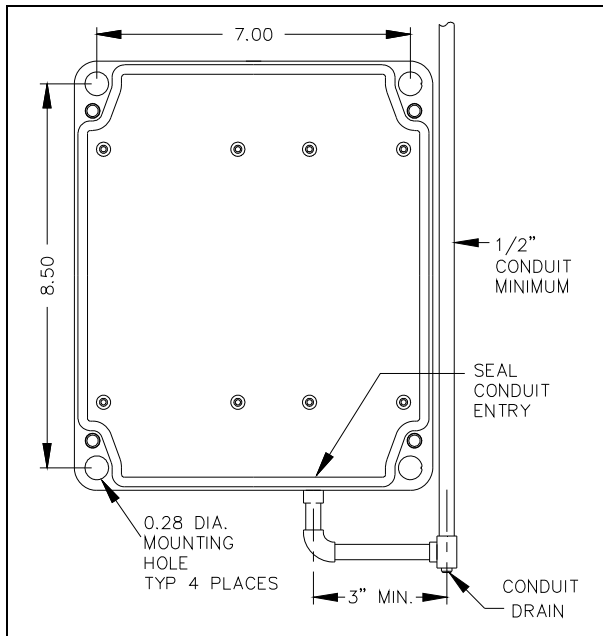

Figure 1. Bottom entry conduit recommended for non-metallic enclosures

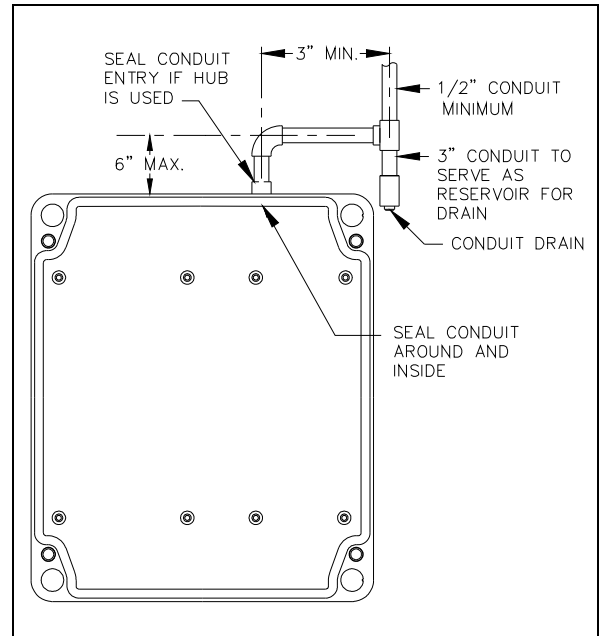

Figure 2. Top entry conduit installation for non-metallic enclosures (NOT recommended)

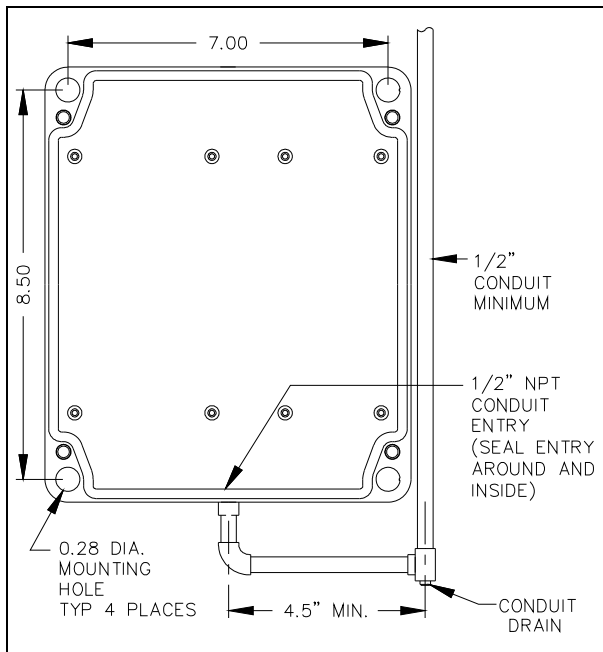

Figure 3. Bottom entry conduit installation details for metallic enclosures

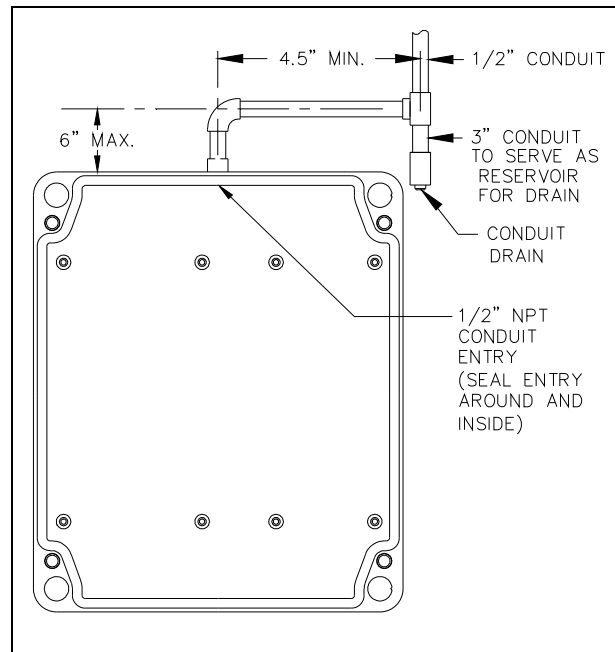

Figure 4. Top entry conduit installation details for metallic enclosures (NOT recommended)

Models 393-00xAD and 393AL-00xAD

The mounting and wiring instructions are as follows:

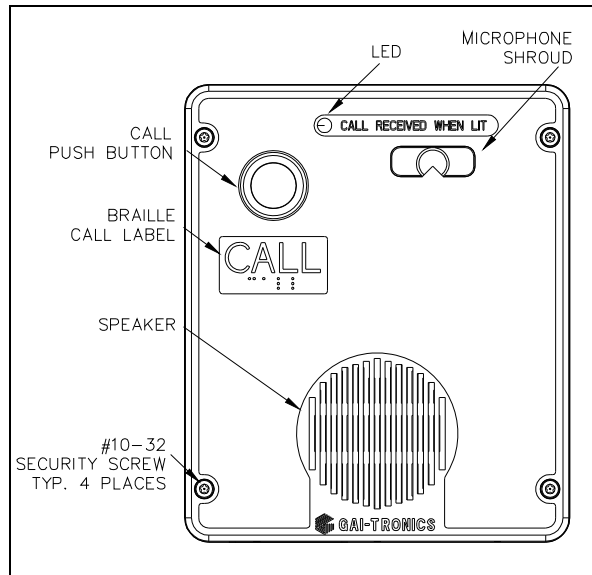

Figure 5. Model 393-001AD Telephone in a Non-Metallic Enclosure

1. Remove the four security screws from the front panel and set the panel assembly aside, protecting it from possible damage.

2. Position the enclosure on the mounting surface. The enclosure provides four 0.28-inch mounting holes in a 7.0 × 8.5-inch hole pattern. Secure the enclosure to its mounting surface with four ¼-inch diameter bolts of the appropriate length for the surface.

NOTE: When using the GAI-Tronics Model 231-001 Pole Mounting Kit, follow the mounting instructions provided in the kit.

3. For Model 393-00xAD only: Create a conduit access hole using a Greenlee-type punch that is equivalent in size to the conduit diameter. Bottom entry is strongly recommended. Insert a conduit fitting in the access hole.

4. Install conduit as required. Refer to the conduit installation details on Page 6.

NOTE: Use **silicone sealant or equivalent around and inside all conduit entries.**

5. Pull the telephone line through the conduit and into the enclosure. Connect the telephone line to the customer-supplied telephone line surge suppressor (if applicable) and modular jack (USOC RJ11 or CA11A) provided with the unit.

Note: The modular jack may be mounted inside the telephone. Telephone line connections directly to TB1 are acceptable.

If using the modular jack, remove the cover, and connect the telephone line's tip (+) wire to the green wire on the modular jack, and the ring (-) wire to the red wire on the modular jack. Replace the modular jack cover.

6. Allow the telephone a minimum of 35 seconds to initialize.

7. Using the "Setup" section of this manual,

- Configure the hardware as required. Refer to the "Hardware Configuration" section on Page 16 for details.
- Adjust the audio levels, if necessary. Refer to Figure 15 for "Speaker Volume" and "Microphone Sensitivity" potentiometer locations.
- Perform the initial programming. Refer to the "Programming" section on Page 21.

8. Verify operation by calling to and from another telephone.

9. Complete the installation by attaching the front panel assembly to the rear enclosure using the four security screws, 10–12 in-lbs. of torque is recommended.

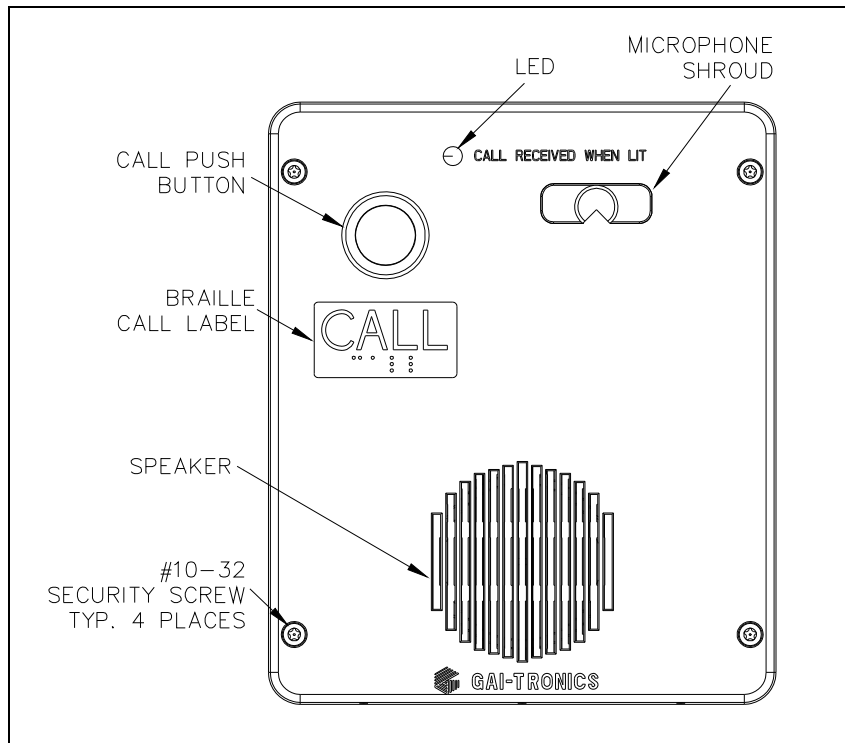

Figure 6. Model 393AL-001AD

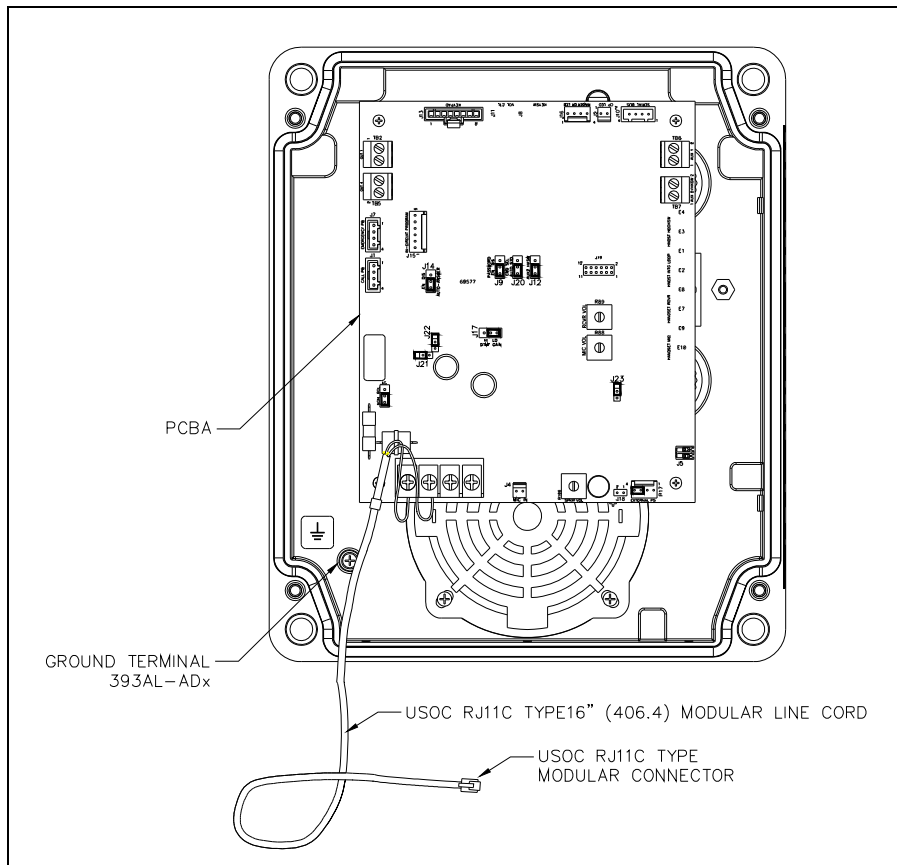

Figure 7. Model 393-00xAD and 393AL-00xAD Component Locations

Model 397-00xAD (Stanchion or Flush-Mount Applications)

1. When mounting in a GAI-Tronics Model 234 Series Stanchion, or for flush-mount installations, the supplied back box must be used. Mount the back box to the structure using appropriate hardware. Refer to Figure 9 cutout dimensions.

NOTE: If mounted outdoors, the installation of a telephone line suppressor (customer-supplied) on the telephone line is recommended.

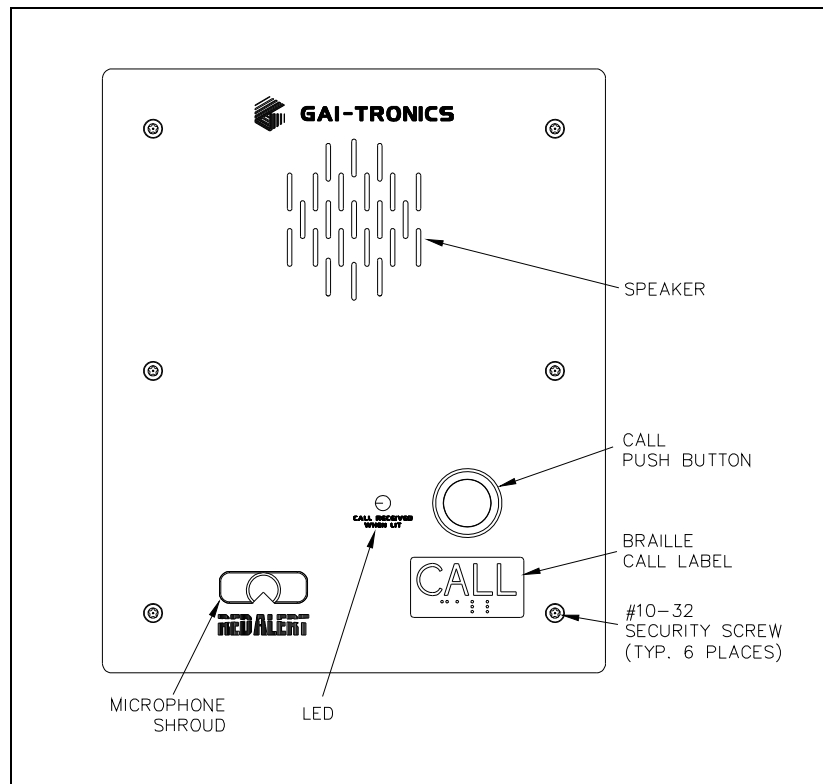

Figure 8. Model 397-00xAD

2. Remove the tapered plug from either of the cable entry holes in the back box, and install the telephone line and cable fitting.
NOTE: Telephone line connections directly to TB1 are acceptable.
3. If using the modular jack, remove the cover, and connect the telephone line's tip (+) wire to the green wire on the modular jack, and the ring (-) wire to the red wire on the modular jack. Replace the modular jack cover.
4. Connect the telephone's modular plug to a USOC RJ11 or CA11A (Canada) modular connector or (if applicable) the telephone line suppressor. An inline coupler is provided for use, if necessary. Refer to Figure 9 for mounting details and Figure 15 for component locations.
5. Allow the telephone a minimum of 35 seconds to initialize.

6. Using the “Setup” section of this manual,
 - Configure the hardware as required. Refer to the “Hardware Configuration” section on Page 16 for details.
 - Adjust the audio levels, if necessary. Refer to Figure 15 for “Speaker Volume” and “Microphone Sensitivity” potentiometer locations.
 - Perform the initial programming. Refer to the “Standard Mode Programming” section on Page 21.
7. Verify operation by calling to and from another telephone.
8. Complete the installation by attaching the front panel assembly to the rear enclosure mounting flanges using the six supplied #10-32 security screws and washers, 10–12 in-lbs. of torque is recommended.

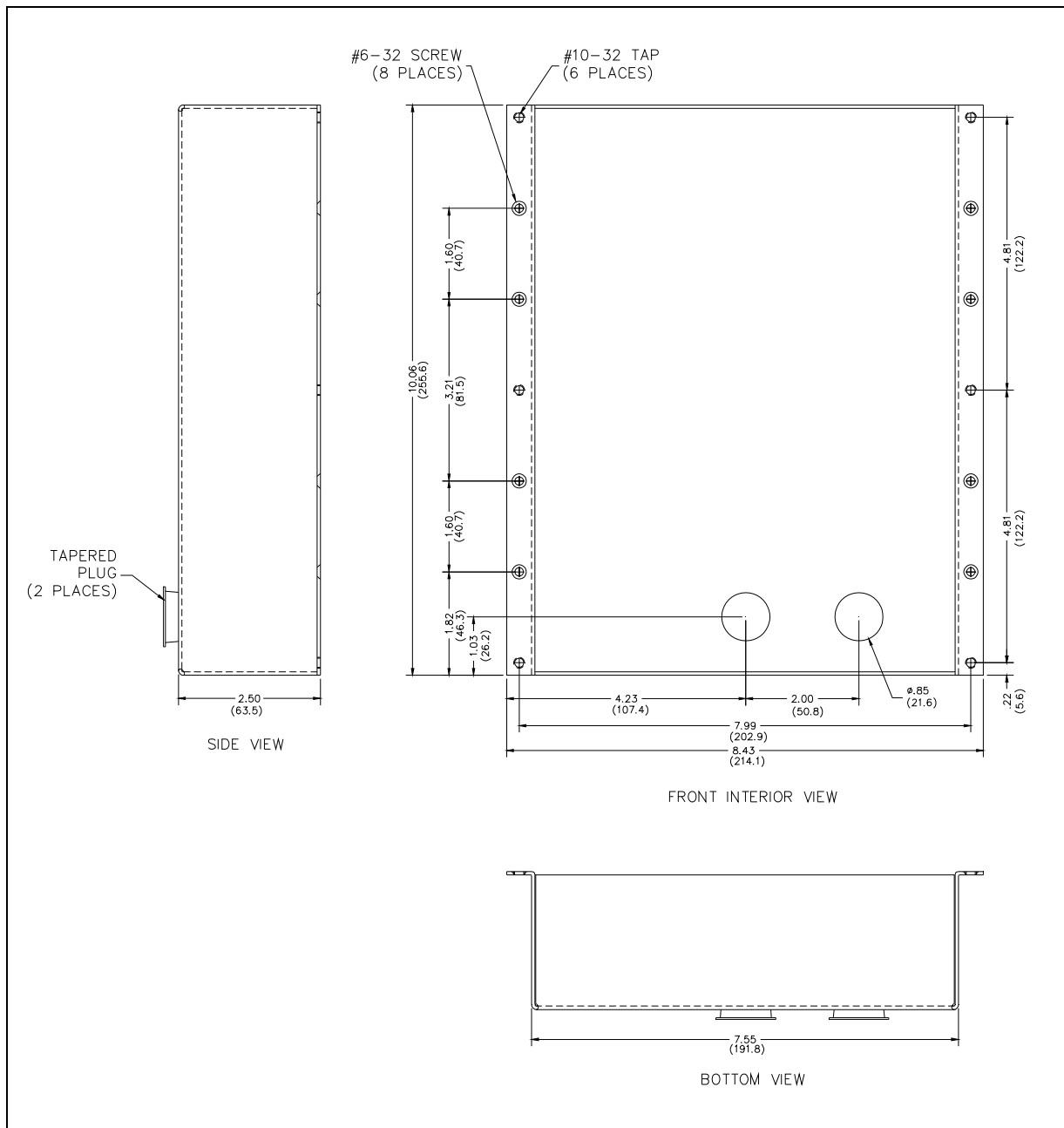

Figure 9. Model 397-00xAD Mounting Details

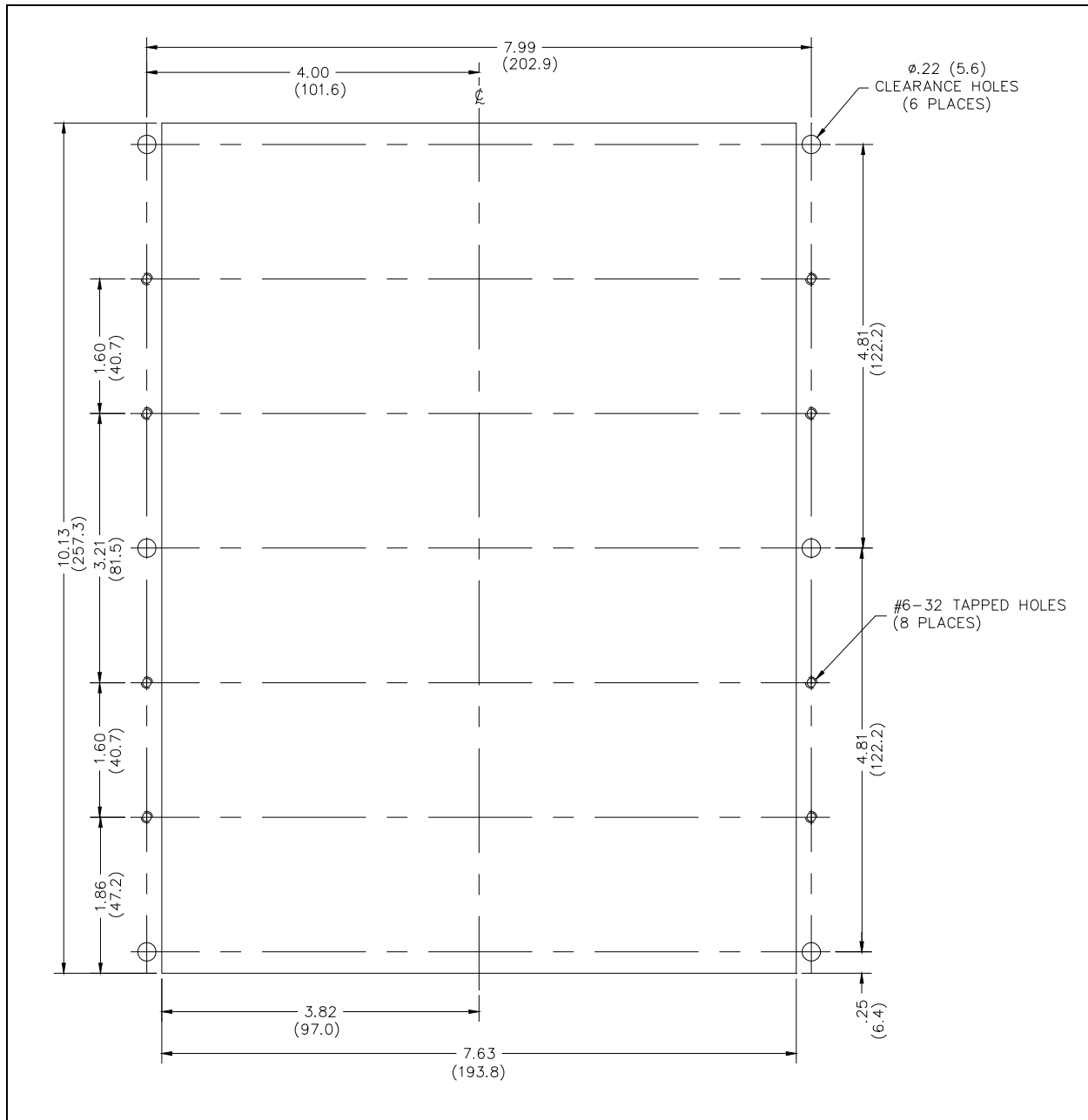

Figure 10. Cutout for Model 397-00xAD

Model 397-001ADFS (Flush-Mount Applications)

This compact model telephone is designed for flush-mount installation in openings measuring 7.75 H × 5.75 W inches utilizing a six-hole mounting pattern.

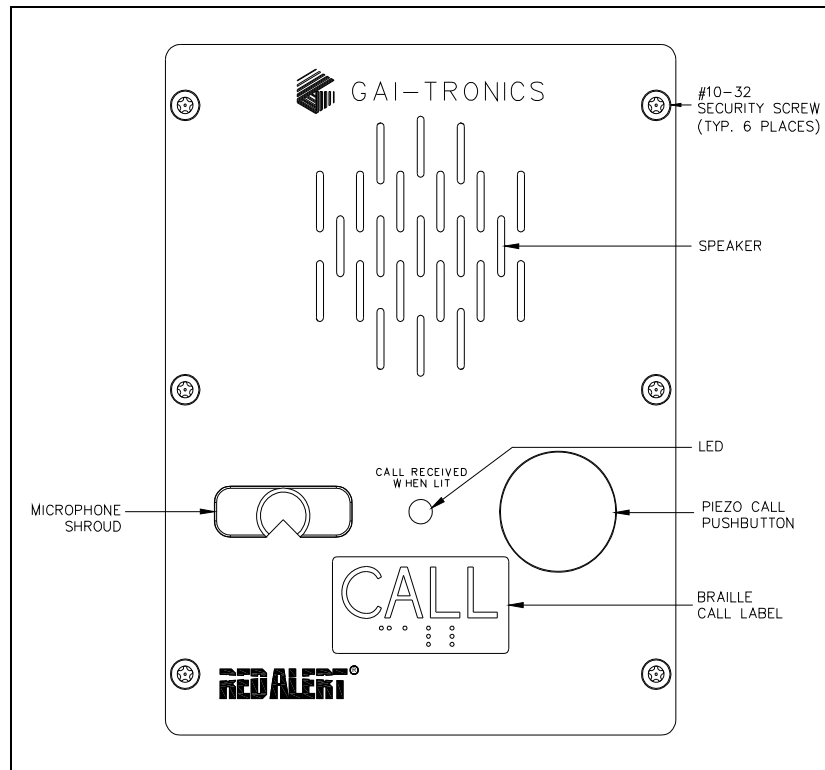

Figure 11. Model 397-001ADFS

1. Remove the back box from the front cover.

NOTE: If mounted outdoors, the installation of a telephone line suppressor (customer-supplied) on the telephone line is recommended.
2. Feed the telephone line through either of the cable entry holes in the back box.

NOTE: Telephone line connections directly to TB1 are acceptable.
3. Connect the telephone's modular plug into a USOC RJ11 or CA11A (Canada) modular connector or (if applicable) the telephone line suppressor. An inline coupler is provided for use, if necessary. Refer to Figure 12 and Figure 13 for mounting details and Figure 15 for component locations.
4. Reinstall the back box to the front cover.
5. Allow the telephone a minimum of 35 seconds to initialize.
6. Using the "Setup" section of this manual,
 - Configure the hardware as required. Refer to the "Hardware Configuration" section on Page 16 for details.
 - Adjust the audio levels, if necessary. Refer to Figure 15 for "Speaker Volume" and "Microphone Sensitivity" potentiometer locations.
 - Perform the initial programming. Refer to the "Standard Mode Programming" section on Page 21.

7. Verify operation by calling to and from another telephone.
8. Complete the installation by attaching the front panel assembly to the mounting surface using the six supplied #10-32 security screws and washers, 10–12 in-lbs. of torque is recommended.

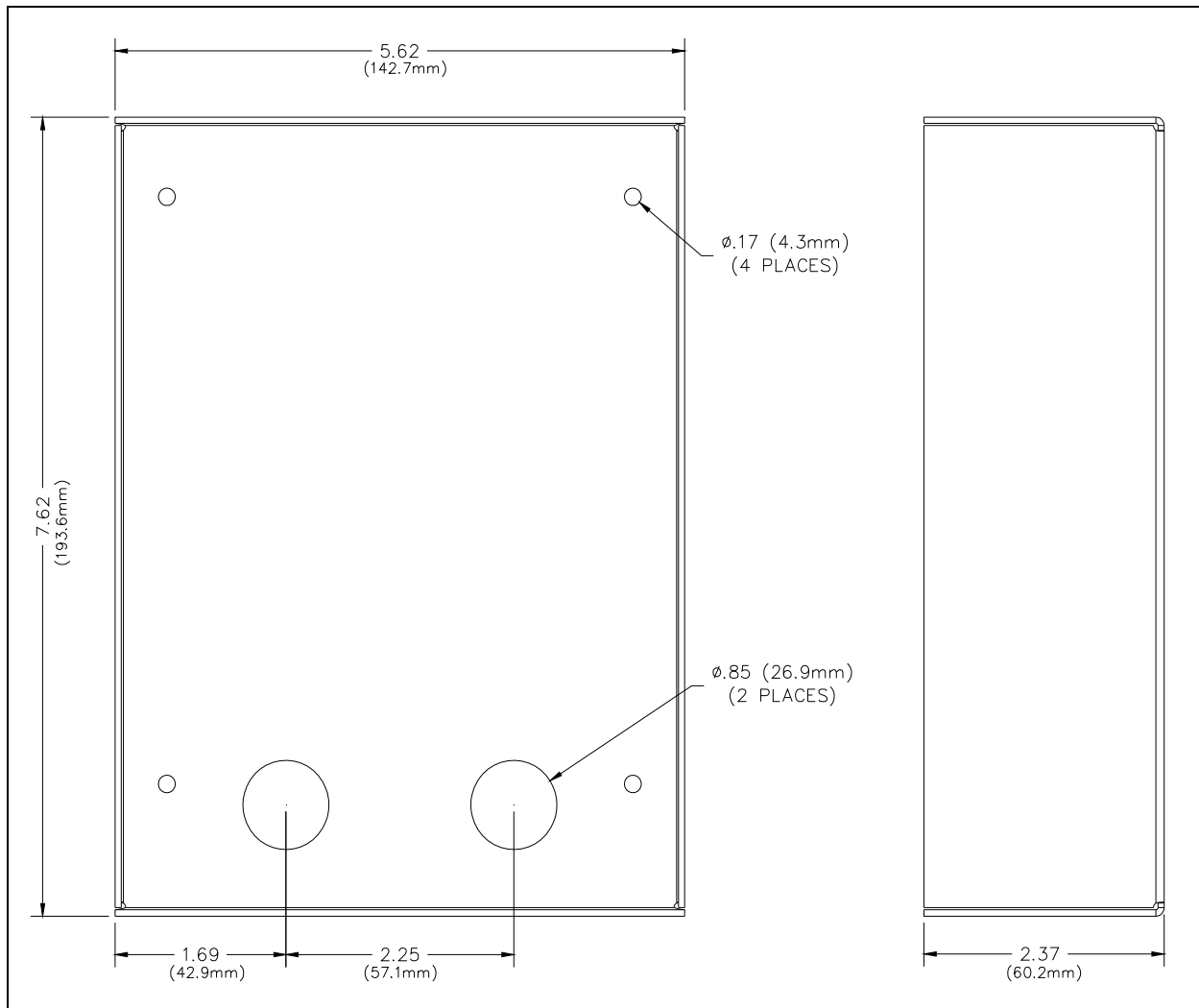

Figure 12. Model 397-001ADFS Back Box

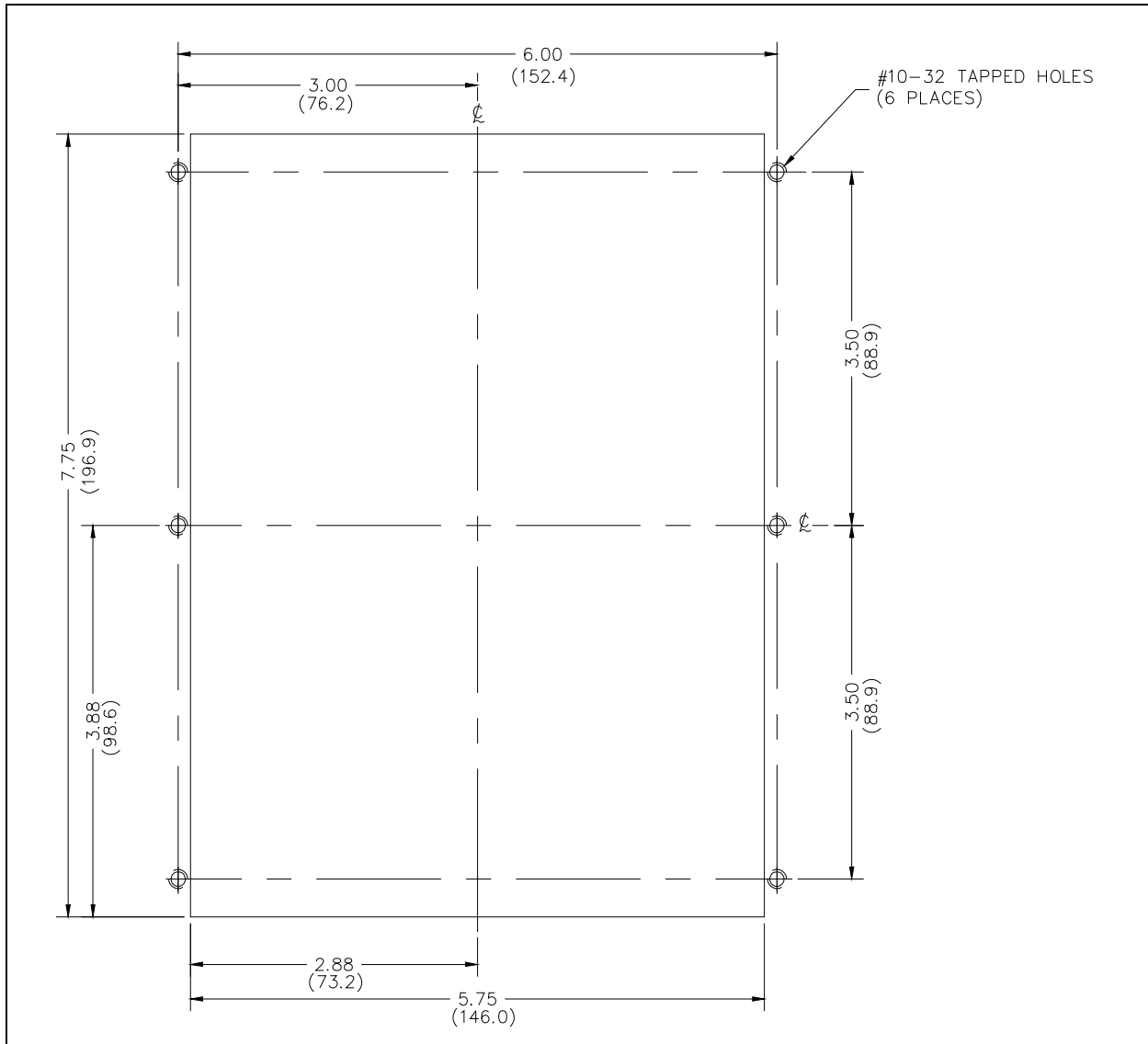

Figure 13. Cutout for Model 397-001ADFS

External Power for -003AD Models

The plug-in power supply is used for operations below -4°F (-20°C) and requires 120 V ac input to provide a 5 V dc output to the unit. The plug-in power supply is equipped with a 4-foot power cable with integral connector that plugs into P17 on the telephone PCBA. Remove the jumper from P17 pins 3 and 4 and insert it on the adjacent header J18 when using the plug-in power supply. See Figure 15 on Page 18 for jumper locations.

NOTE: The external power supply provided with these models does not provide telephone line power for communications. It simply activates a heater circuit to allow operation to -40°C .

GAI-Tronics Strobe Connection

Figure 14 below shows a typical connection detail of the GAI-Tronics 540-001/530-001/531A Strobe (sold separately).

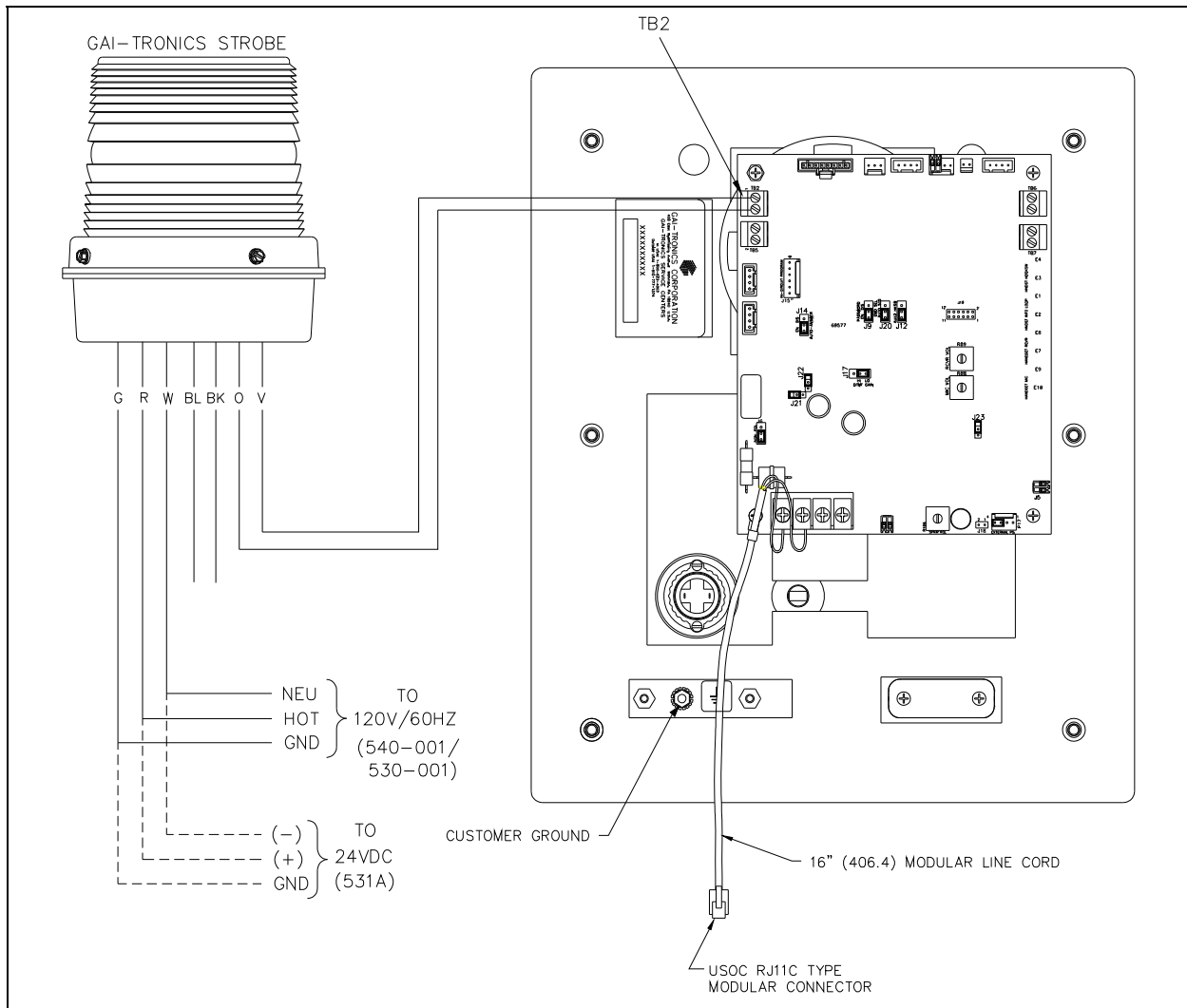

Figure 14. (Model 397-00xAD is shown as an example)
 Connection to Optional GAI-Tronics 540-001, 530-001, 531A Strobe

Setup

Hardware Configuration

The hardware configuration options are explained in detail in the following sections and the necessary jumper settings are identified to enable or disable each option. Reading each section and recording the selected options prior to making the necessary changes is recommended. Create a record of your settings using Table 2 on Page 17. See Figure 15 on Page 18 for the jumper locations.

Auto-answer Configuration

Factory Setting: Auto-answer feature enabled

The Auto-answer feature enables or disables the automatic answering of an incoming call, which allows TMA to monitor the health of this telephone via polling with SMART operation enabled and remote programming in standard mode. When the Auto-answer feature is enabled, the telephone automatically answers the call and attempts to communicate with TMA. If the caller is not TMA, the telephone automatically transitions to a standard two-way communication.

Enable: J14 jumper in position EN.

Disable: J14 jumper in position DIS (Do not use this setting except under the direction of GAI-Tronics personnel.)

NOTE: The Auto-answer feature must be enabled to allow the GAI-Tronics Telephone Management Application PC to contact the telephone or to allow remote touch tone programming.

Polarity Configuration

Factory Setting: Non-polarity sensitive

This telephone can be configured to be polarity or non-polarity sensitive. With the non-polarized setting, the telephone operates regardless of tip and ring polarity. With the polarized setting, the telephone only operates with the telephone line's positive terminal connected to the tip terminal. Use the polarity sensitive setting to allow a line voltage reversal disconnect signal to disconnect the call.

Non-polarity Sensitive: J6 jumper in position NON.

Polarity Sensitive: J6 jumper on in position POL.

DTMF Gain Select Configuration

Factory Setting: Low Gain selected.

Two gain selections are available in the DTMF detection circuit. In most installations, the low gain setting is recommended. The high gain setting may be necessary if the telephone is not responding to manual or TMA-generated DTMF commands.

Low Gain Selected: J17 jumper in position LO.

High Gain Selected: J17 jumper in position HI.

Password Enable Configuration

Factory Setting: Password Enabled

This telephone can be configured to enable or disable the password protection for programming (Standard Mode only). This can be useful when initially programming the telephones.

Password Enabled: J9 jumper in position EN.

Password Disabled: J9 jumper in position DIS.

Command Select Configuration

Factory Setting: Auto

The purpose of jumper J20 is to enable or disable automatic transition to SMART operation. With this jumper in the standard position, SMART operation is disabled.

SMART Operation Enabled (Auto): J20 jumper in position AUTO.

SMART Operation Disabled (Standard): J20 jumper in position STD.

Low-Power Mode Configuration

Factory Setting: Low-Power Mode Disabled

For some installations in which only minimal loop current is available, the performance of the telephone may be improved by enabling this feature. Symptoms of minimal loop current may include low speaker volume and/or momentary muting of audio. In the majority of applications, however, the low-power mode should be disabled. The low-power mode is enabled by installing the following three jumpers: J21, J22, and J23.

Low-Power Mode Enabled: Jumpers installed at J21, J22, and J23.

Low-Power Mode Disabled: Jumpers NOT installed at J21, J22, and J23.

Hardware Settings

Table 2. Hardware Settings Table

Function	Default Settings		User Settings	
	Setting	Jumper/Position	Setting	Jumper/Position
Auto-answer	Enabled	J14/EN		
Password Protection	Enabled	J9/EN		
Line Polarity	Non-polarized	J6/NON		
Command Select	Auto	J20/AUTO		
DTMF Gain Select	Low Gain	J17/LO		
Low-Power Mode	Disabled	J21, J22, J23 not installed		

Extreme Cold Temperature Option

RED ALERT® Auto-Dial Telephones equipped with the Extreme Cold Temperature Option (-003AD models) are capable of operating to $-40\text{ }^{\circ}\text{C}$ (non-option models are rated to $-20\text{ }^{\circ}\text{C}$). This option includes two identifying features.

Each telephone is shipped with a plug-in power supply that requires a 120 V ac input to provide a 5 V dc output to the unit. The power supply is equipped with a 4-foot power cable with integral connector, which plugs into P17 on the telephone PCBA. P17 must be vacated prior to plugging in the power supply. To do so, remove the jumper from P17 pins 3 and 4 and plug it into the adjacent J18 header. Refer to Figure 15 for the connector locations.

In addition to the plug-in power supply, the -003AD models have had the standard tactile (moveable) push button (CALL) replaced with non-tactile (non-moveable) push button. Use of a non-moveable switch eliminates the possibility of water or melting snow from forming and freezing behind the push button, ultimately preventing the movement necessary for activation.

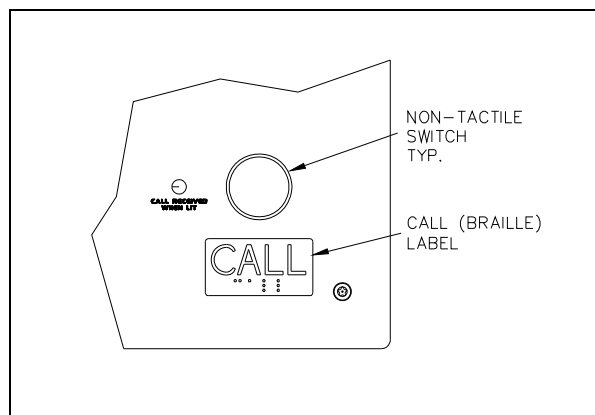

Figure 16. Extreme Cold Temperature Piezo Button (Typical)

NOTE: RED ALERT telephone models ending with the “FS” suffix are equipped with non-tactile pushbutton(s) making them extreme cold weather capable. Operation to $-40\text{ }^{\circ}\text{F}$ ($-40\text{ }^{\circ}\text{C}$) can be accomplished by adding a No. 40404-045 Power Supply (120 V ac required).

Auxiliary Output Control

As previously noted, each RED ALERT® Telephone is capable of providing two isolated control outputs in the form of a dry (voltage-free) contact closure rated for 125 mA at 48 V dc or 80 mA at 28 V ac.

Output one connects to TB2 on the telephone’s PCBA (refer to Figure 15). This output closes when an auto-dial call begins (auto-dial CALL push button activation only) and remains in that state for the duration of the telephone call. The typical use of this output is to activate the flashing sequence on a GAI-Tronics Strobe.

NOTE: Output one can be programmed to remain closed for up to 255 minutes (in one-minute increments) after the auto-dial call ends. This output extension can be deactivated via an external switch or by pressing “*921” on the keypad of the called telephone while the call is in progress. The RED ALERT® Telephone will acknowledge acceptance of this deactivation command with a short beep. If the beep is not initially received, retry the command. This feature requires the use of GAI-Tronics No. 40404-045 Plug-in Power Supply (120 V ac source required).

Output four connects to TB5 on the telephone's PCBA (adjacent to TB2). This output can be remotely controlled via an appropriate DTMF command. This remote control output can be used to activate or control a door latch, gate relay solenoid, alarm, etc. from the called party location.

Auxiliary control example: Output four used for gate entry

A Model 393-001AD RED ALERT® Auto-dial Telephone is installed at the entrance to a gated/secure community. A visitor or delivery person approaches the gate and presses the CALL push button, which automatically calls the security office. Upon verification of approved entry, the security guard presses the pre-programmed, DTMF "open gate" command. This command causes the RED ALERT® telephone's Output four relay contact to close for a pre-programmed amount of time then release. The RED ALERT® Telephone will acknowledge acceptance of this deactivation command with a short beep. If the beep is not initially received, retry the command.

Due to the low current rating of the output contact, an interposing relay will be required that, when energized, will switch a higher voltage to a gate solenoid and cause the gate to open. Refer to Figure 17 below.

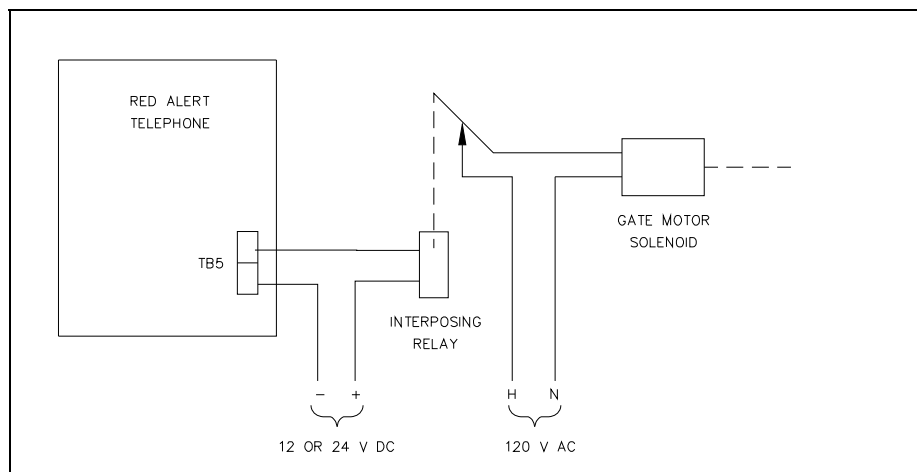

Figure 17. Example of RED ALERT® Telephone Installed for Gate Operation

The output pulse duration (closure) and the DTMF code used as the "open gate" command are user programmable. Refer to the "Standard Mode Programming" section for key sequence program settings on Page 21.

Please note that TMA may be used to change the contact closure settings, if the RED ALERT® Telephone is operating in SMART mode.

Standard Mode Programming

Prior to programming the RED ALERT® Telephones read the “Programming Information” section in its entirety, record the desired key sequences and jumper settings in the “User Settings” section of Table 2 on Page 17 and Table 11 on Page 30, and then complete the programming as specified.

This “Programming” section has been divided into two distinct subsections; “**Standard Mode**” and “**SMART Mode**.” Standard Mode programming is used if the telephone system installation does not include the TMA (Telephone Management Application) PC software. With TMA installed, the telephones will be monitored and the SMART Mode programming should be used. Normal telephone operation is identical in either mode of operation.

Each RED ALERT® Telephone is factory-programmed to receive standard mode commands. Factory-default settings are shown in Table 11 on Page 30.

Set-up Sequence

Set up each RED ALERT® Auto-Dial Telephone for either “remote” access programming or for “local” access programming (keypad required).

Remote

Using a touch-tone telephone, call the RED ALERT® Auto-Dial Telephone. The telephone will automatically answer the call and generate a splash tone (low to high sequence), followed by a success tone (short beep). Proceed to the “Programming Sequence” section on Page 21.

Local

1. Local programming will require the use of a No. 51035-011 Keypad and No. 61504-048 Keypad Cable Assembly. The keypad and cable must be connected to J13 on the PCBA. Refer to Figure 15 for the location of J13.
2. Press the CALL push button. When the dial tone is heard from the speaker, simultaneously press the “1” and “#” keypad buttons. The RED ALERT® telephone will generate a splash tone (low to high sequence), followed by a success tone (short beep). Proceed to the “Programming Sequence” section on Page 21.

Programming Sequence

The following command sequences are common to both “remote” and “local” programming and are used to configure the telephone to the desired operating parameters.

1. Dial the factory-default password **2468** (or appropriate customer-selected password). A success tone (short beep) is generated to indicate that “standard” programming mode has been accessed.
2. After hearing the password success tone, begin entering each desired programming key sequence. A success tone (short beep) is generated each time a new key sequence is accepted. An error tone (two low tones) is generated to indicate an error. If an error tone is generated, verify the key sequence and enter the sequence again.
3. To terminate the programming call:
 - a. Remote – Place the programming telephone on hook. The RED ALERT® telephone will automatically end the programming call within 20 seconds.

- b. Local – Press the **CALL** push button (whichever is connected to J1) to end the call. Restore any moved push-button harness connectors to their original position (if necessary).

NOTES:

1. The RED ALERT® telephone will automatically time out and disconnect if 20 seconds elapses between digit entries, or if an invalid password is entered.
2. If DTMF digits have not been dialed within 3 seconds of the first success tone, the telephone will exit programming mode and revert to a standard voice call.
3. If the password success tone is not generated, the telephone has failed to recognize the password. Therefore, the telephone must then be programmed with the password disabled. Refer to the “Password Disabled Programming” section on Page 22.

Password Disabled Programming

The programmable features of the RED ALERT® Auto-Dial Telephones are protected by a factory default or user specified password, as previously described. Situations may arise when a setting change is required but the password is forgotten or unknown. To permit continued programming support in this situation, converting to Password Disable Programming may be necessary and is described as follows:

1. Access the telephone’s PCBA and disable the password protection feature by changing jumper J9 to the “DIS” position.
2. Confirm the auto-answer feature is enabled (jumper J14 should be in the “EN” position).
3. Using a touch-tone telephone, call the RED ALERT® Telephone. The telephone will automatically answer the call and will generate a splash tone (low to high sequence) followed by a success tone (single beep).
4. Begin entering the desired key sequences as previously described, following steps 2 and 3 in the “Programming Sequence” section on Page 21.

Programming Information

The programming information on the following pages explains the programming options. The telephone is shipped from the factory with a set of default parameters that are listed in the programming table on Page 30. A “User Settings” section has been provided in the programming table for the user to record the selected programming parameters.

Programming Legend

D = DTMF digit 0–9, *, or #
N = Numeric digit 0–9
L = 0 - Disable, 1 - Enable

Dialing Options

The auto-dial telephones can be configured for either auto-dialing or ring-down operation. Select the dialing option that fits your application. The dialing options are explained in detail below.

Auto-dialing

The CALL push button can be programmed to call up to three unique telephone numbers. The unique telephone numbers include a primary telephone number and two backup, or roll over, numbers. In the event that an auto-dial call cannot connect to the primary telephone number (i.e., a busy signal or no answer), the auto-dial telephone will automatically dial the first backup, or roll over, number. Again, in the event that an auto-dial call cannot connect to the first back-up telephone number, the auto-dial telephone will automatically dial the second backup, or roll over, number (if configured). This sequence will continue until the auto-dial call is answered or all numbers have been attempted (one attempt each).

When operating in SMART mode, the number of attempts to call each programmed number can be increased, as required, (two attempts each, three attempts each, etc.).

For the rollover feature to function properly in this mode, all three auto-dial memories must be programmed with valid telephone numbers. The three auto-dial numbers can be the same or any combination of telephone numbers. If the telephone is programmed with only one or two auto-dial numbers, the rollover operation will not function and the numbers will only be dialed one time.

If an auto-dial telephone is connected to a PBX, PABX, KSU, etc. telephone system, the auto-dial telephone can be programmed to access outside CO lines. Typically access to a CO line requires adding a digit (e.g., 9) to the auto-dial number. Also, a “pause” may be required in the auto-dial number. The pause typically is required to wait for the secondary (CO line) dial tone. See the example in the Call Button Auto-dial Number 1 on Page 24.

In addition to the pause, the auto-dial telephone has programmable “Primary Dial Tone Delay” and “Secondary Dial Tone Delay” capabilities. Both delays determine the amount of time that the auto-dial telephone will wait before dialing the stored telephone number. The secondary dial tone delay can only be used if a “9” is dialed to gain access to a CO line.

Ring-down Operation

Ring-down operation enables the telephone to go off-hook when the CALL push button is pressed. The ring-down system must detect loop current and ring-down to the appropriate telephone.

Table 3. Auto-Dialing Key Sequence Setup

Feature	Key Sequence	Description	Default
CALL Button Auto-dial Number 1	DD ... *1	<p>Assigns a telephone number to the auto-dial memory 1. DD ... represents the telephone number, which can be up to 24 digits in length.</p> <p>For access to an outside line, a pause may be required in the telephone number to wait for secondary dial tone. The *# represents a pause in the telephone number.</p> <p><i>Examples:</i></p> <p>To assign the police emergency number 911 to the auto-dial button, enter 911*1.</p> <p>To assign 911 when a “9” is required to gain access to a CO line, enter 9*#911*1.</p> <p>To store * or # as part of the auto-dial number, (such as for speed dialing), enter these digits twice in succession.</p>	None
CALL Button Auto-dial Number 2	DD ... *2	Same as CALL Button Auto-dial Number 1 except the sequence ends in *2 instead of *1.	None
CALL Button Auto-dial Number 3	DD ... *3	Same as CALL Button Auto-dial Number 1 except the sequence ends in *3 instead of *1.	None
Primary Dial Tone Delay	# 1 0 NN	<p>The dial tone delay is the amount of time the unit can wait for a dial tone before auto-dialing the telephone number. (00* [20 seconds]; 01–15 seconds)</p> <p><i>Example:</i> To wait up to 5 seconds for a dial tone, enter # 1 0 0 5.</p> <p>*NOTE: If dial tone is not detected then autodialing does not occur.</p>	03 (3 seconds)
Secondary Dial Tone Delay	# 1 1 NN	<p>This feature is only used if you must dial 9 to access an outside line. It determines the amount of time (00–15 seconds) the telephone waits for a second dial tone. The first programming step indicated you must program 9*# and the number you want the auto-dial to access. This programming parameter allows you to choose the amount of time the telephone waits after sending the 9 and pausing before dialing the auto-dial number.</p> <p><i>Example:</i> To wait 10 seconds for the second dial tone, enter # 1 1 1 0.</p>	02 (2 seconds)
Ring-down Operation	*1	This option clears the telephone number to prevent auto-dialing when the button is pressed. After the button is pressed, the ring-down system must detect loop current and ring-down to the appropriate telephone.	None

Password Protection

The Password Protection feature allows you to change the four-digit password required to program the auto-dial telephone. Each telephone is password protected to maintain the integrity of programmed information and should not be disabled.

The password is required to enter the programming mode when programming the telephone locally or from a remote location. The programming password hardware configuration must be enabled when programming with the password. To enable the Password Protection feature, jumper J9 must be in the “EN” position. Complete the key sequence to change the four-digit password.

Table 4. Password Programming

Feature	Key Sequence	Description	Default
Password Protection	# 1 4 N N N N	A four-digit password must be supplied to remotely program the telephone. If you change the password and cannot enter programming mode, see the “Password Disabled Programming” section. <i>Example:</i> To program the password 1234, enter # 1 4 1 2 3 4.	2468

Auto-Answer Alert Feature

When auto-answering an incoming call, the RED ALERT® Telephone will generate a splash tone on the telephone line. This tone is always heard by the calling party. This tone can be pre-programmed to also be heard over the telephone’s integral speaker using this key sequence.

Table 5. Auto-Answer Alert Programming

Feature	Key Sequence	Description	Default
Auto-answer Alert	# 1 6 L	The Auto-Answer Alert feature allows a person to call the telephone and monitor the area around the telephone with or without sounding a splash tone over the unit’s integral speaker. (Disable alert tone), L=0. (Enable alert tone), L=1.	1 (Enabled)

Disconnect Options

Several options are available for disconnecting a call. Any combination of disconnect options may be used. Select the method that best suits the application, and follow the appropriate programming directions.

Table 6. Disconnect Options

Feature	Key Sequence	Description	Default
HELP Push-button Disconnect Option	# 1 7 L	<p>The CALL push button cannot be used to disconnect a call for 10 seconds after initially pressing the push button. However, the CALL push button can be used to disconnect calls after the 10-second push button lockout period elapses when $L = 1$. To prevent the CALL push button from disconnecting the call, set $L = 0$.</p> <p><i>Example:</i> To enable the CALL push button disconnect, enter # 1 7 1. To disable the CALL push button disconnect, enter # 1 7 0.</p>	1 (Enabled)
Call Time-out Disconnect Option	# 1 2 N N	<p>This feature programs the maximum length of a call if no other disconnect features are used. The valid entries are 1–99, representing 1-minute increments and 0 representing 4.5 hours. The call duration timer begins when the auto-dial telephone goes off-hook. The auto-dial telephone automatically disconnects after the programmed time-out period elapses.</p> <p>The user can press the CALL button to immediately disconnect the current call. This feature helps prevent non-emergency calls from tying up emergency lines for long lengths of time.</p> <p><i>Example:</i> To make the maximum call length 2 minutes, enter # 1 2 0 2.</p>	10 (10 minutes)
Dial Tone Disconnect Option	# 1 9 L	<p>NOTE: Use this option only if no other disconnect options are available.</p> <p>If this option is enabled, the telephone automatically terminates a call if it detects a dial tone continuously for 10 seconds, such as if the called party hangs up. To enable the dial tone disconnect, $L=1$. To disable the dial tone disconnect, $L = 0$.</p> <p><i>Example:</i> To enable the dial tone disconnect, enter # 1 9 1. To disable the dial tone disconnect, enter # 1 9 0.</p>	0 (Disabled)

Americans with Disabilities Act (ADA) Programming

The ADA features provide the following benefits:

- CALL RECEIVED WHEN LIT indication - This lamp provides indication to hearing-impaired individuals that the auto-dial call has been answered.
- The Location Identification Code - This feature enables security personnel to quickly and easily locate an individual in trouble.
- DTMF Call Disconnect - Enables the security operator to disconnect the call by pressing ##.

Table 7. Americans with Disabilities Act (ADA) Programming

Feature	Key Sequence	Description	Default
DTMF Disconnect Option	# 1 8 L	This option controls the DTMF “##” disconnect feature. To enable, set L=1. To disable, set L=0.	1 (Enabled)
Location Identification ID Setup	# 1 3 L N N N	This option enables and stores the three-digit location identification ID number. To enable the ID feature, set L=1. To disable the ID feature, L=0. Enter the three-digit location identification code in the sequence N N N. <i>Example:</i> To enable the location ID feature and store the three-digit ID code 357, enter # 1 3 1 3 5 7 . To disable the location ID feature, enter # 1 3 0 0 0 . NOTE: The ADA options must also be enabled.	No default setting. The user must complete this step to have the identification code transmitted.

Extended Strobe Operation (Requires External Power Supply)

Output 1 can be programmed for extended operation (remain closed) for up to 255 minutes (in 1-minute increments) after the auto-dial call ends.

Table 8. Extended Strobe Operation

Feature	Key Sequence	Description	Default
Extended Strobe Operation	# 2 5 N N N	Sets the duration of the activation of the Output 1 contact starting at the end of a call. Use entries 001–255, representing 1 minute to 255 minutes in 1-minute increments. Use 000 to disable this feature. To set a duration of 7 minutes, enter # 2 5 0 0 7 .	0 0 0 (Disabled)

Output 4 Control Setup

The command (DTMF key sequence) that triggers the timed activation of Output 4 contact closure (TB5) is configurable. The sequence can contain up to eight DTMF digits in the 0–9 range. The first digit must not be 0 (zero). Some examples of valid control sequences are: 87654321; 832; and even a single digit such as 7. The duration of the activation (closure) of Output 4 can be set in the range of 0.1 to 12.7 seconds in 0.1-second increments.

Table 9. Output 4 Control Options

Feature	Key Sequence	Description	Default
Control Sequence	N N..* 8	Assigns the digits NN.. as the command key sequence that triggers the timed activation of Output 4. NN is a sequence of 1–8 digits, with the first digit not zero. To assign “726” as the control sequence, enter 7 2 6 * 8 .	90125
Duration of Timed Activation	# 2 6 N N N	Sets the duration of the activation of the Output 4 contact when triggered by the control sequence. Use entries 001–127, representing 0.1 second to 12.7 seconds in 0.1-second increments. Use 000 to disable this feature. To set a duration of 7 seconds, enter # 2 6 0 7 0 .	5 seconds

Early Microphone Option

The microphone in each telephone activates only after the unit determines connection to the called party. Based on factory-default programming, this will occur in one of two ways; when the telephone receives a DTMF “*” from the called party or when the telephone detects that no more ring-backs from the called number are occurring. This ring-back determination may take four to six seconds to detect, rendering the microphone non-active for that time.

Enabling the “Early Microphone” feature activates the microphone when the telephone begins checking for ring-back tones, typically within less than 1 second after the unit completes the dialing sequence.

Use of the “Early Microphone” feature includes an operational risk that ring-back tones can be missed or audio received by the microphone can be recognized by the telephone, causing it to operate as if the call had been answered. This could prevent call “rollover” from occurring.

It is strongly recommended that the early microphone feature be used only if the telephone number being called by the auto-dial telephone is attended 24 hours per day. If call rollover is desired, the appropriate feature setting is early microphone option disabled.

Table 10. Early Microphone Option

Feature	Key Sequence	Description	Default
Early Microphone Option Enable	# 7 1 1	Provide microphone activation within 1 second of dial sequence completion.	No
Early Microphone Option Disable	# 7 1 0	Returns telephone to default operation of microphone.	Yes

Table 11. Programming Documentation Table

Function	Key Sequence	Default Settings	User Settings
Auto-dial or Ring-Down Programming (see Table 3 on Page 24)			
CALL Button Auto-dial Number 1	<i>DD*1</i>	None	
CALL Button Auto-dial Number 2	<i>DD*2</i>	None	
CALL Button Auto-dial Number 3	<i>DD*3</i>	None	
Primary Dial Tone Delay	<i>#10NN</i>	3 seconds	
Secondary Line Dial Tone Delay	<i>#11NN</i>	2 seconds	
Ring-down Operation	<i>*1</i>	None	
Password Protection Feature Programming (see Table 4 on Page 25)			
Password Protection	<i>#14NNNN</i>	2468	
Disconnect Options Programming (see Table 6 on Page 26)			
Push-button Disconnect	<i>#17L</i>	1 (enabled)	
Call Time-out Disconnect	<i>#12NN</i>	10 minutes	
Dial Tone Disconnect	<i>#19L</i>	0 (disabled)	
ADA Programming (see Table 7 on Page 27)			
DTMF Disconnect Option	<i>#18L</i>	1 (enabled)	
Identification Code Entry	<i>#13LNNN</i>	None	
Other Programming Features			
Auto-Answer Alert Feature (see Table 5 on Page 25)	<i>#16L</i>	0 (disabled)	
Extended Strobe Operation (see Table 8 on Page 27)	<i>NN...*8</i> <i>#26NNN</i>	90125 #26050 (5 sec.)	
Output 4 Control Setup (see Table 9 on Page 28)	<i>#25NNN</i>	0 0 0 (disabled)	
Early Microphone Option (see Table 10 on Page 29)	<i>#71L</i>	0 (disabled)	
Table Legend			
D = DTMF digit 0–9, *, or #		N = Numeric digit 0–9	L = 0-Disable, 1-Enable

SMART Mode Programming

TMA Software is designed to remotely program RED ALERT® Telephones for SMART mode operation. Although they can be locally programmed for SMART operation, there is no advantage to having a RED ALERT® Telephone set up for SMART mode without having TMA installed.

RED ALERT® Telephones installed in systems that will have TMA operational at a later date are recommended to be programmed for standard mode operation. Upon installation of TMA, the installed telephones can be reprogrammed from the TMA PC.

Maintenance

Service

If your RED ALERT® Telephone requires depot repair service, contact your GAI-Tronics Regional Service Center for a return authorization number (RA#). Equipment should be shipped prepaid to GAI-Tronics with a return authorization number and a purchase order number. If the equipment is under warranty, repairs will be made without charge. Please include a written explanation of all defects to assist our technicians in their troubleshooting efforts.

Call 800-492-1212 inside the USA or 610-777-1374 outside the USA for help identifying the Regional Service Center closest to you.

Preventive Maintenance for Models 397-001AD, 397-001ADFS, and 397-003AD

Stainless steel does not normally require maintenance to prevent corrosion from occurring. Different installation locations may require more regular maintenance than others, depending on the environment and exposure to airborne contaminants. The following maintenance steps should be performed on a regular basis or when corrosion is first noticed on your Model 397-001AD, 397-001ADFS, or 397-003AD.

Cleaning

- For general cleaning, wipe the surface with a cleanser or a cleanser and water mixture. Any cleanser that is safe for glass is usually safe for stainless steel. Wipe dry.
- If corrosion or rusting is noticed, remove with a non-abrasive commercial cleanser and water. Rub stained areas in the same direction as the existing grain. Stubborn stains may be removed with a magnesium oxide, ammonia, and water paste. Wipe clean, rinse with water, and dry.

Corrosion Prevention

Automotive wax provides the best results in preventing corrosion on stainless steel. Simply apply wax, let dry to a haze, and buff to a shine with a clean dry cloth. This application should protect the telephone surface for many months as it will allow natural reformation of the chromium oxide layer.

Do NOT use steel wool, sandpaper, mineral acids, bleaches, or chlorine cleansers on the stainless surface.

Replacement Parts

Part No.	Description	393-001AD	393-003AD	393AL-001AD	393AL-003AD	397-001AD	397-001ADFS	397-003AD
233-001	Model 233-001 Security Screwdriver	■	■	■	■	■	■	■
12562-108	PCBA, Replacement Kit	■	■	■	■	■	■	■
12542-002	Security Screws, (Torx T-25), ½ inch, Pack of 15					■	■	■
12516-003	Security Screws, (Torx T-25), 1-½ inches, Pack of 10	■	■	■	■			
12520-010*	Push-button Replacement Kit	■		■		■		
12520-012 †	Piezo Push-button Kit, Black		■		■		■	■
40404-045	Replacement Plug-in Power Supply (provided with Extreme Cold Temperature Option)		■		■		■	■
12521-004	Microphone Replacement Kit	■	■	■	■	■	■	■
12522-007	Piezo Speaker Replacement Kit	■	■	■	■	■	■	■

*Used on the -001AD models.

†Used on the -003AD models.

Specifications

TMA compatibility profile type GTC SMART Hands-free
 Auto-dial digit limit 24 digits

Electrical

Audio output 1 kHz tone – 87 ±3 dB SPL @ 1 m with 40 mA loop current
 Battery voltage (tip and ring) 24 V dc or 48 V dc
 Phone line requirements Loop start, central office (CO), or
 Analog station port (PBX, PABX, or KSU)
 Minimum loop current 24 mA (35 mA recommended)
 Auxiliary output (Isolated solid state switch) 125 mA @ 48 V dc
 80 mA @ 28 V ac
 Signaling DTMF 100 ms tone
 Memory Non-volatile EEPROM

Mechanical

Operating temperature range

-003AD Models -40 °F to +140 °F (-40 °C to +60 °C)

-001AD Models -4 °F to +140 °F (-20 °C to +60 °C)

Relative humidity to 95%, noncondensing

Model 393-00xAD

Enclosure construction Valox® (high impact, glass-reinforced polyester) painted safety yellow

Dimensions 9.5 H × 8.0 W × 4.0 D in (241.3 × 203.2 × 101.6 mm)

Weight 4.0 lb (1.8 kg)

Models 393AL-00xAD

Enclosure construction Cast aluminum painted safety yellow

Dimensions 9.5 H × 8.0 W × 4.0 D in (241.3 × 203.2 × 101.6 mm)

Weight 7.8 lb (3.5 kg)

Models 397-00xAD

Construction

Panel 14-gauge, type 304 brushed stainless steel

Back box 16-gauge cold-rolled steel with black polyurethane finish

Dimensions

Front panel 12.00 H × 10.00 W in (305 × 254 mm)

Back box (overall) 10.06 H × 8.43 W × 2.50 D in (256 × 214 × 63.5 mm)

Cutout for mounting back box 10.13 H × 7.63 W in (257 × 194 mm)

Weight 6.5 lb (2.9 kg)

Model 397-001ADFS

Construction

Panel 14-gauge, type 304 brushed stainless steel

Back box 16-gauge cold-rolled steel with black polyurethane finish

Dimensions

Front panel 8.5 H × 6.5 W in (215 × 165.1 mm)

Back box (overall) 7.62 H × 5.62 W × 2.37 D in (193.6 × 142.7 × 60.2 mm)

Cutout for flush mounting 7.75 H × 5.75 W in (196.9 × 146.1 mm)

Weight 5 lb (2.3 kg)

Approval Standards

Safety of Information Technology Equipment UL/CSA 60950

Enclosures for Electrical Equipment Type 3R

47 CFR Part 68

Certification Number US: ADGTE05BGTC2010

Ringer Equivalence Number 0.5B

Network connection (USOC) RJ11

IC Information (Canada)

IC Certification Number 822B-GTC2010

Ringer Equivalence Number 0.5B

Connection Method CA11A

User Instructions (USA)

This equipment complies with Part 68 of the FCC rules and the requirements adopted by the ACTA. On this equipment is a label that contains, among other information, a product identifier in the format US:AAAEQ##TXXXX. If requested, this number must be provided to the telephone company.

User Instructions (Canada) CP-01, Issue 8, Part I: Section 14.1

NOTICE: The Industry Canada label identifies certified equipment. This certification means that the equipment meets certain telecommunications network protective, operational and safety requirements as prescribed in the appropriate Terminal Equipment Technical Requirements document (s). The Department does not guarantee the equipment will operate to the user's satisfaction. Before installing this equipment, users should ensure that it is permissible to be connected to the facilities of the local telecommunications company. The equipment must also be installed using an acceptable method of connection. The customer should be aware that compliance with the above conditions may not prevent degradation of service in some situations. Repairs to certified equipment should be coordinated by a representative designated by the supplier. Any repairs or alterations made by the user to this equipment, or equipment malfunctions, may give the telecommunications company cause to request the user to disconnect the equipment. Users should ensure for their own protection that the electrical ground connections of the power utility, telephone lines and internal metallic water pipe system, if present, are connected together. This precaution may be particularly important in rural areas.

CP-01, Issue 8, Part I: Section 14.2

NOTICE: The **Ringer Equivalence Number (REN)** assigned to each terminal device provides an indication of the maximum number of terminals allowed to be connected to a telephone interface. The termination on an interface may consist of any combination of devices subject only to the requirement that the sum of the Ringer Equivalence Numbers of all the devices does not exceed 5.

Warranty

Equipment. GAI-Tronics warrants for a period of one (1) year from the date of shipment, that any GAI-Tronics equipment supplied hereunder shall be free of defects in material and workmanship, shall comply with the then-current product specifications and product literature, and if applicable, shall be fit for the purpose specified in the agreed-upon quotation or proposal document. If (a) Seller's goods prove to be defective in workmanship and/or material under normal and proper usage, or unfit for the purpose specified and agreed upon, and (b) Buyer's claim is made within the warranty period set forth above, Buyer may return such goods to GAI-Tronics' nearest depot repair facility, freight prepaid, at which time they will be repaired or replaced, at Seller's option, without charge to Buyer. Repair or replacement shall be Buyer's sole and exclusive remedy. The warranty period on any repaired or replacement equipment shall be the greater of the ninety (90) day repair warranty or one (1) year from the date the original equipment was shipped. In no event shall GAI-Tronics warranty obligations with respect to equipment exceed 100% of the total cost of the equipment supplied hereunder. Buyer may also be entitled to the manufacturer's warranty on any third-party goods supplied by GAI-Tronics hereunder. The applicability of any such third-party warranty will be determined by GAI-Tronics.

Services. Any services GAI-Tronics provides hereunder, whether directly or through subcontractors, shall be performed in accordance with the standard of care with which such services are normally provided in the industry. If the services fail to meet the applicable industry standard, GAI-Tronics will re-perform such services at no cost to buyer to correct said deficiency to Company's satisfaction provided any and all issues are identified prior to the demobilization of the Contractor's personnel from the work site. Re-performance of services shall be Buyer's sole and exclusive remedy, and in no event shall GAI-Tronics warranty obligations with respect to services exceed 100% of the total cost of the services provided hereunder.

Warranty Periods. Every claim by Buyer alleging a defect in the goods and/or services provided hereunder shall be deemed waived unless such claim is made in writing within the applicable warranty periods as set forth above. Provided, however, that if the defect complained of is latent and not discoverable within the above warranty periods, every claim arising on account of such latent defect shall be deemed waived unless it is made in writing within a reasonable time after such latent defect is or should have been discovered by Buyer.

Limitations / Exclusions. The warranties herein shall not apply to, and GAI-Tronics shall not be responsible for, any damage to the goods or failure of the services supplied hereunder, to the extent caused by Buyer's neglect, failure to follow operational and maintenance procedures provided with the equipment, or the use of technicians not specifically authorized by GAI-Tronics to maintain or service the equipment. **THE WARRANTIES AND REMEDIES CONTAINED HEREIN ARE IN LIEU OF AND EXCLUDE ALL OTHER WARRANTIES AND REMEDIES, WHETHER EXPRESS OR IMPLIED BY OPERATION OF LAW OR OTHERWISE, INCLUDING ANY WARRANTIES OF MERCHANTABILITY OR FITNESS FOR A PARTICULAR PURPOSE.**

Return Policy

If the equipment requires service, contact your Regional Service Center for a return authorization number (RA#). Equipment should be shipped prepaid to GAI-Tronics with a return authorization number and a purchase order number. If the equipment is under warranty, repairs or a replacement will be made in accordance with the warranty policy set forth above. Please include a written explanation of all defects to assist our technicians in their troubleshooting efforts.

Call 800-492-1212 (inside the USA) or 610-777-1374 (outside the USA) for help identifying the Regional Service Center closest to you.