



GAI-TRONICS®
A HUBBELL COMPANY

305-003 Line Balance Assembly

Confidentiality Notice

This manual is provided solely as an installation, operation, and maintenance guide and contains sensitive business and technical information that is confidential and proprietary to GAI-Tronics. GAI-Tronics retains all intellectual property and other rights in or to the information contained herein, and such information may only be used in connection with the operation of your GAI-Tronics product or system. This manual may not be disclosed in any form, in whole or in part, directly or indirectly, to any third party.

The following are trademarks of GAI-Tronics Corporation:

SmartSeries®

Page/Party®

ADVANCE

SmartVolume™

General Information

GAI-Tronics' Model 305-003 Line Balance assembly properly loads both the page and party line circuits, of a GAI-Tronics Page/Party communication system, with the correct impedance. Every Page/Party system must have at least one line balance assembly. Use the line balance assembly in single- or multi-party (up to five) line systems.

Installation

Location

There are three primary considerations determining the location of the line balance assembly. It should be:

- near the electrical center of the system,
- adjacent to an indoor station in a relatively quiet area, and
- no more than 5,280 feet (1600 m) from the most distant station, when used with standard GAI-Tronics cable.

Contact a GAI-Tronics representative for further information for larger systems or when using non-standard cable. The line balance assembly has one electrical adjustment that is made using a Page/Party station (see the [Line Balance Assembly Adjustment](#) section).

Mounting

Mount the assembly by suspending it from a 3/4-inch conduit nipple (customer supplied), from the lower side of an indoor wall station, or by using the mounting ears, on the box (see [Figure 1](#)).

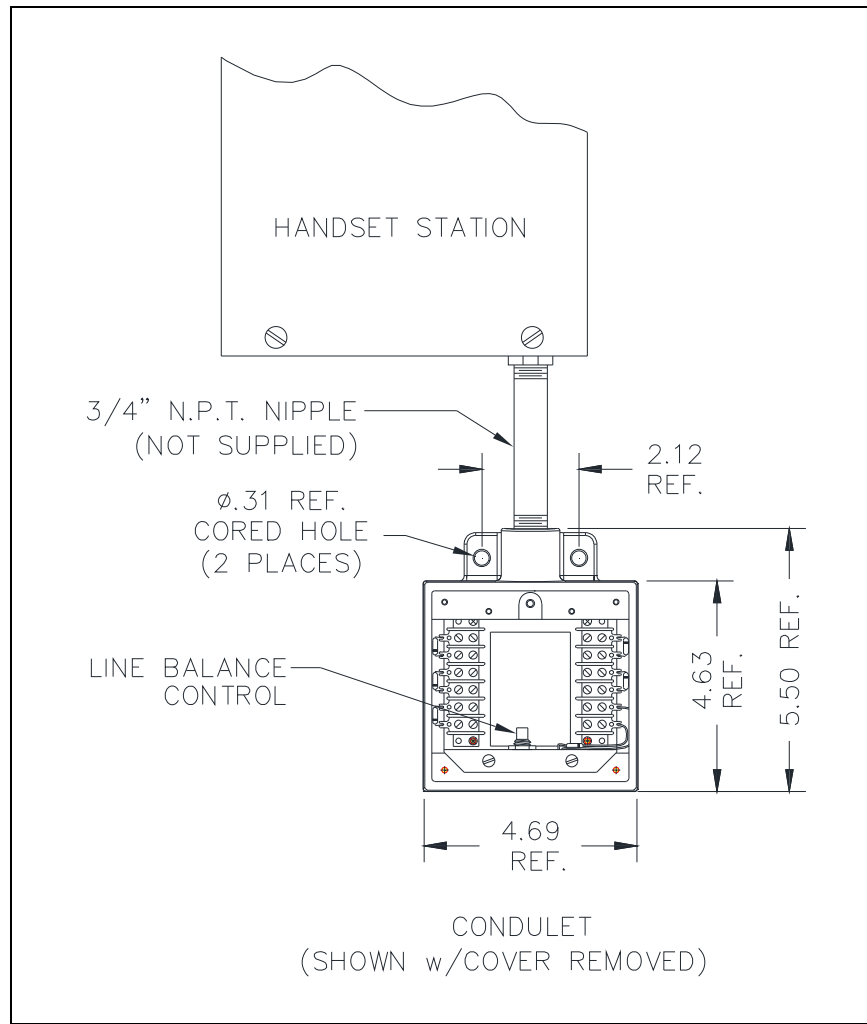

Figure 1. Typical Line Balance Assembly Installation

Wiring

Use one twisted pair for the page circuit and additional pairs, for each party line circuit, to connect the line balance assembly's terminal blocks to the associated indoor wall station.

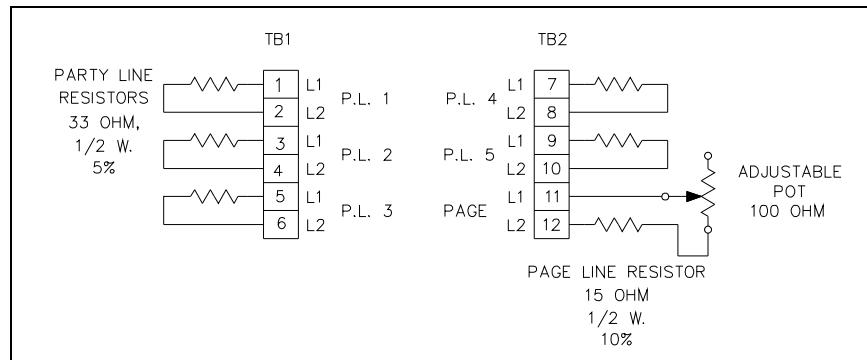

Figure 2. Line Balance Assembly Terminal Block Connections

Line Balance Assembly Adjustment

1. Remove the line balance assembly cover to expose the line balance control.
2. Set the control for proper *page circuit loading*:
 1. lift the handset from the adjacent handset station and press the push-to-page button.
 2. From a normal speaking distance (approximately 1/2 inch), blow steadily into the handset microphone.
 3. Adjust the control to minimize receiver sidetone.

(Sidetone is the amount of signal transmitted from the microphone of a handset to the ear piece, i.e., how loudly the speaker hears their own voice.)

NOTE: Make this adjustment only during initial system installation. However, repeat the *page circuit loading* adjustment if adding or removing more than 10 speaker amplifier stations.

3. Replace the cover after final adjustment.
4. Secure with four mounting screws.

This discourages tampering by unauthorized personnel and prevents entry of contaminants.

For more detailed system installation information, please refer to GAI-Tronics Pub. 42004-139 for 700 Series 120 V ac systems, or Pub. 42004-140 for 700 Series 24 V dc systems.

Specifications

Wiring	barrier-type terminal block
Mounting.....	two holes in mounting ears or supported by an installed 3/4-inch conduit nipple between the conduit hub and the handset station
Enclosure	cast iron two-gang outlet box and dust-tight aluminum cover with gasket
Control	page circuit line balance control
Finish	epoxy
Dimensions	5.5 H × 4.7 W × 2.3 D in (139.7 × 119.4 × 58.4 mm)
Shipping weight	4.0 lb (1.8 kg)

Warranty

Equipment. GAI-Tronics warrants for a period of one (1) year from the date of shipment, that any GAI-Tronics equipment supplied hereunder shall be free of defects in material and workmanship, shall comply with the then-current product specifications and product literature, and if applicable, shall be fit for the purpose specified in the agreed-upon quotation or proposal document. If (a) Seller's goods prove to be defective in workmanship and/or material under normal and proper usage, or unfit for the purpose specified and agreed upon, and (b) Buyer's claim is made within the warranty period set forth above, Buyer may return such goods to GAI-Tronics' nearest depot repair facility, freight prepaid, at which time they will be repaired or replaced, at Seller's option, without charge to Buyer. Repair or replacement shall be Buyer's sole and exclusive remedy. The warranty period on any repaired or replacement equipment shall be the greater of the ninety (90) day repair warranty or one (1) year from the date the original equipment was shipped. In no event shall GAI-Tronics warranty obligations with respect to equipment exceed 100% of the total cost of the equipment supplied hereunder. Buyer may also be entitled to the manufacturer's warranty on any third-party goods supplied by GAI-Tronics hereunder. The applicability of any such third-party warranty will be determined by GAI-Tronics.

Services. Any services GAI-Tronics provides hereunder, whether directly or through subcontractors, shall be performed in accordance with the standard of care with which such services are normally provided in the industry. If the services fail to meet the applicable industry standard, GAI-Tronics will re-perform such services at no cost to buyer to correct said deficiency to Company's satisfaction provided any and all issues are identified prior to the demobilization of the Contractor's personnel from the work site. Re-performance of services shall be Buyer's sole and exclusive remedy, and in no event shall GAI-Tronics warranty obligations with respect to services exceed 100% of the total cost of the services provided hereunder.

Warranty Periods. Every claim by Buyer alleging a defect in the goods and/or services provided hereunder shall be deemed waived unless such claim is made in writing within the applicable warranty periods as set forth above. Provided, however, that if the defect complained of is latent and not discoverable within the above warranty periods, every claim arising on account of such latent defect shall be deemed waived unless it is made in writing within a reasonable time after such latent defect is or should have been discovered by Buyer.

Limitations / Exclusions. The warranties herein shall not apply to, and GAI-Tronics shall not be responsible for, any damage to the goods or failure of the services supplied hereunder, to the extent caused by Buyer's neglect, failure to follow operational and maintenance procedures provided with the equipment, or the use of technicians not specifically authorized by GAI-Tronics to maintain or service the equipment. **THE WARRANTIES AND REMEDIES CONTAINED HEREIN ARE IN LIEU OF AND EXCLUDE ALL OTHER WARRANTIES AND REMEDIES, WHETHER EXPRESS OR IMPLIED BY OPERATION OF LAW OR OTHERWISE, INCLUDING ANY WARRANTIES OF MERCHANTABILITY OR FITNESS FOR A PARTICULAR PURPOSE.**

Return Policy

If the equipment requires service, contact your Regional Service Center for a return authorization number (RA#). Equipment should be shipped prepaid to GAI-Tronics with a return authorization number and a purchase order number. If the equipment is under warranty, repairs or a replacement will be made in accordance with the warranty policy set forth above. Please include a written explanation of all defects to assist our technicians in their troubleshooting efforts.

Call 800-492-1212 (inside the USA) or 610-777-1374 (outside the USA) for help identifying the Regional Service Center closest to you.