



GAI-TRONICS®
A HUBBELL COMPANY

Model 10962-001 and 10962-002 AMI Redundant Controller Modules

Confidentiality Notice

This manual is provided solely as an operational, installation, and maintenance guide and contains sensitive business and technical information that is confidential and proprietary to GAI-Tronics. GAI-Tronics retains all intellectual property and other rights in or to the information contained herein, and such information may only be used in connection with the operation of your GAI-Tronics product or system. This manual may not be disclosed in any form, in whole or in part, directly or indirectly, to any third party.

General Information

The Model 10962-001 and 10962-002 AMI Redundant Controllers (ARC) are designed for GAI-Tronics Page/Party® or public address systems requiring redundant alarm tone/speech generators. They work in conjunction with the GAI-Tronics Model 10959-105, -106, -207, and -208 Audio Messenger Interface (AMI) units. The AMI acts as the alarm tone/speech generator to produce emergency tones and/or pre-recorded speech messages. Refer to Pub. 42004-399 for more information on the Model 10959-105 and -106 AMIs and Pub. 42004-404 for Models 10959-207 and -208 AMIs.

The ARC and AMI devices can be connected in two different configurations depending on the system requirements. If both AMIs are to be installed at the same location, one Model 10962-002 ARC Module can be used to control both AMIs. Refer to Figure 3. If the AMIs are to be installed at separate locations, one Model 10960-001 ARC Module is required at each location. Each ARC will control its respective AMI. Refer to Figure 4.

In either configuration, one AMI acts as the “active” alarm generator and the other AMI acts as the “back-up.” The ARC module(s) control which AMI is active and which is back-up.

During normal alarm operation, input contacts are applied simultaneously to both the active and back-up AMIs. The ARC module(s) allow only the active generator to play the tone/speech message over the system speakers. The back-up AMI is held in standby mode to prevent audio mixing of the two AMI tone/speech messages.

In the event of a failure of the active AMI, the back-up AMI becomes active and plays its tone/speech message over the system speakers.

Hardware Configuration

The Model 10962-001 Single Redundant Controller Module consists of one AMI Redundancy Controller PCBA mounted to the base and one LCD module mounted to the front of the base. Model 10962-002 Dual Redundant Controller has two 69842-001 AMI Redundancy Controller PCBAs mounted to the base and has two LCD modules mounted to the front of the base.

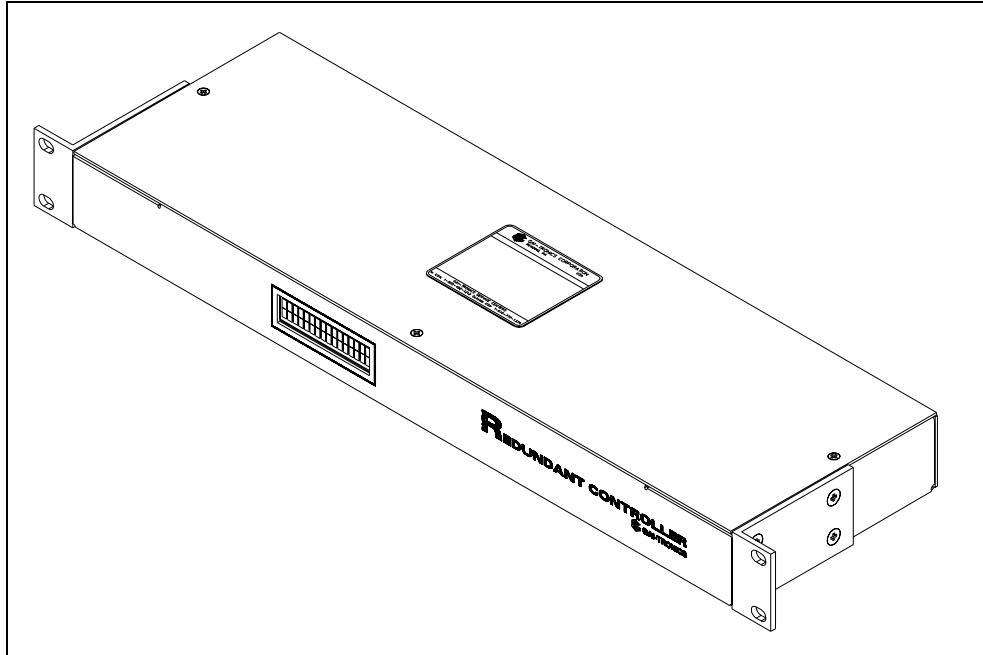

Figure 1. Model 10962-001 Single Redundant Controller for one AMI
Designed for installations where the active and back-up AMIs are installed at separate locations

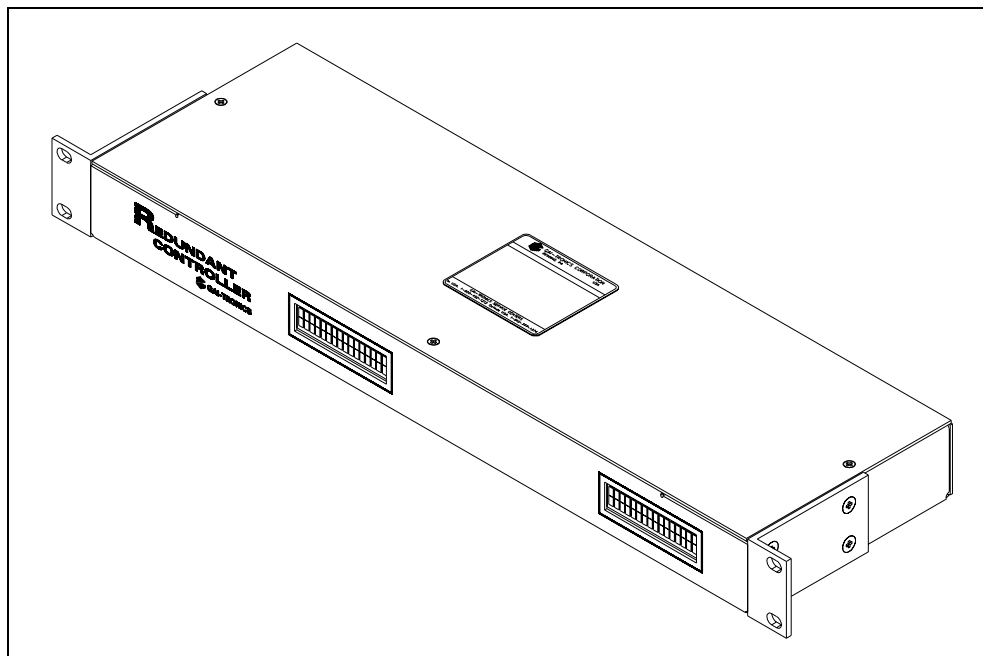

Figure 2. Model 10962-002 Redundant Controller Module
Designed for installations where the active and back-up AMIs are installed at the same location

Block Diagrams

Figure 3 shows the equipment block diagram when the ARC module and AMIs are installed in the same location.

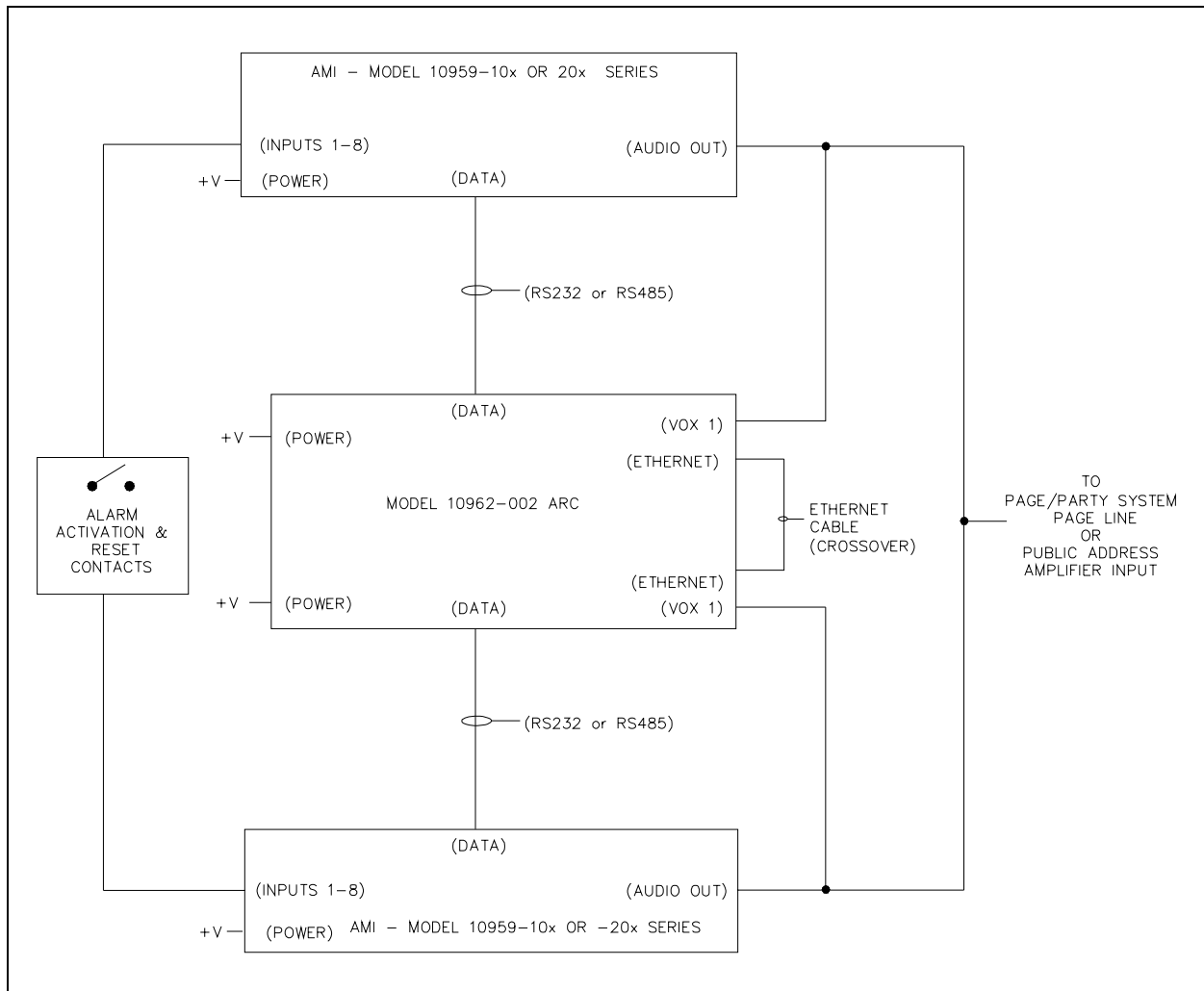

Figure 3. Model 10962-002 ARC and AMI Block Diagram

Figure 4 shows the equipment block diagram when the ARC modules and AMIs are installed in two different locations.

NOTE: When using a CAT 5 cable to directly connect the two ARC modules (as illustrated), the maximum distance between ARC devices is 100 meters. The distance can be extended by using any external Ethernet devices such as fiber optic modems, hubs, etc.

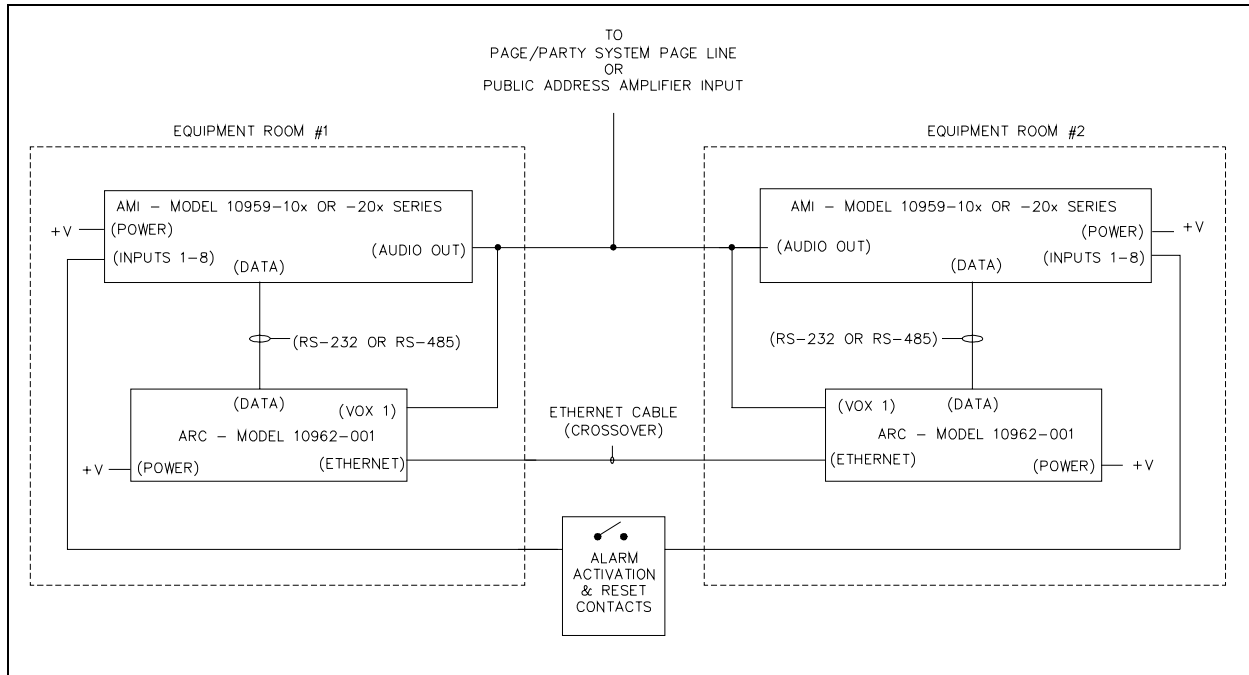

Figure 4. Model 10962-001 ARC and AMI Block Diagram

Installation

Mounting

The Model 10962-001 and -002 Redundant Controller Modules can be mounted in a standard EIA 19-inch electronic equipment rack. Each model requires 1U (1.75 inches) of rack space. Complete the following steps for mounting in the rack:

1. Attach the mounting brackets with the eight 8-32 × 3/8-inch screws provided.
2. Mount the AMI Redundant Controller into the rack using four 10-32 × 3/4-inch screws with plastic shoulder washers.

Wiring Terminations

The Model 10962-001 AMI Redundant Controller provides three terminal blocks, an RJ11 receptacle labeled RS-232, and an RJ45 receptacle labeled ETHERNET on the rear panel for wiring connections. The Model 10962-002 is equipped with two sets of terminal blocks and receptacles since it has two PCBAs. Refer to Figure 5 below for terminal locations.

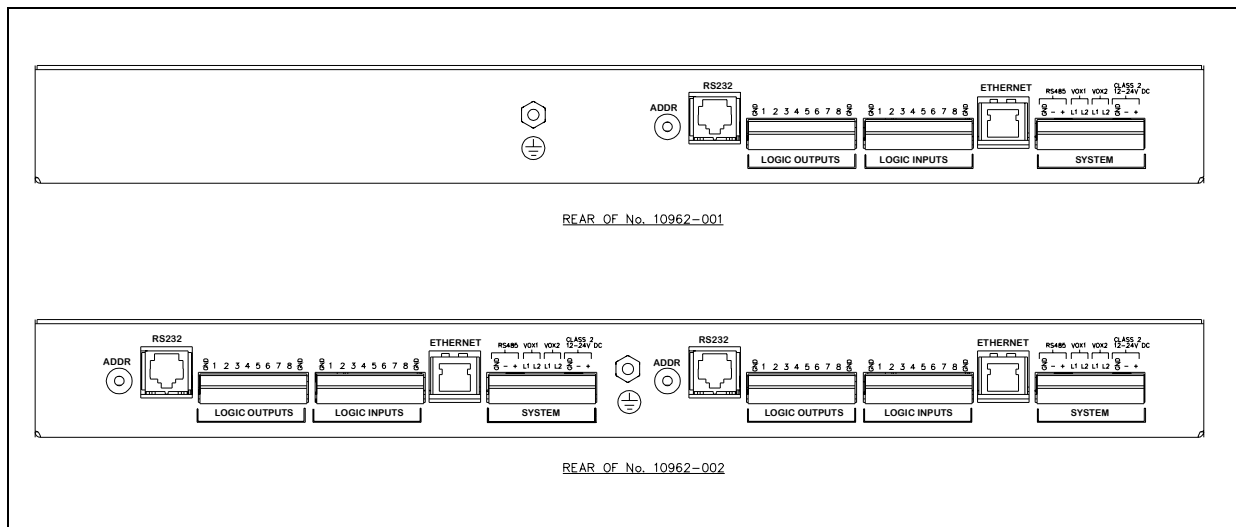

Figure 5. Redundant Controllers - Rear Panels

Refer to Figure 6 for a typical connection diagram between the ARC and the AMI.

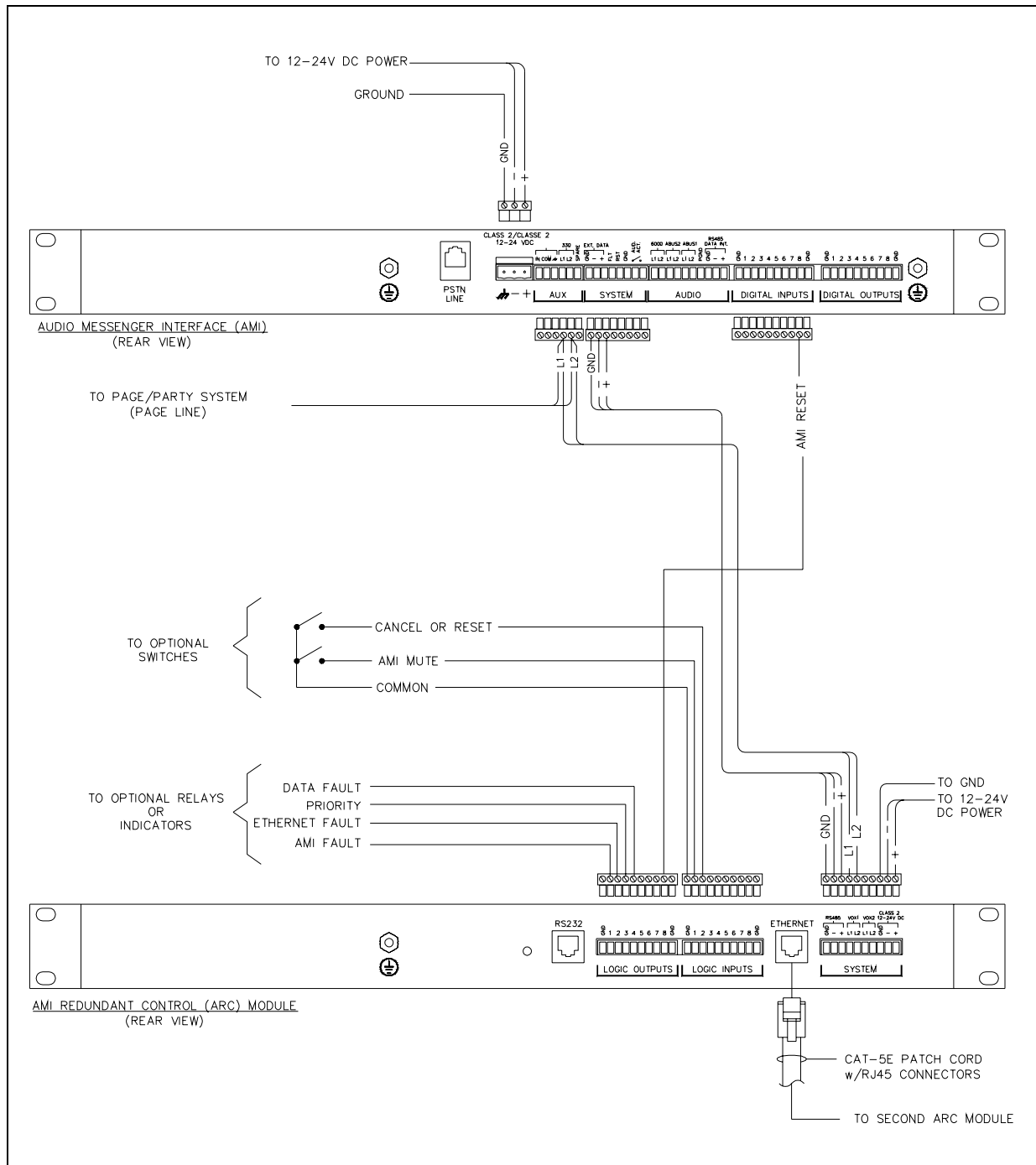

Figure 6. ARC and the 100 Series AMI Connection Diagram

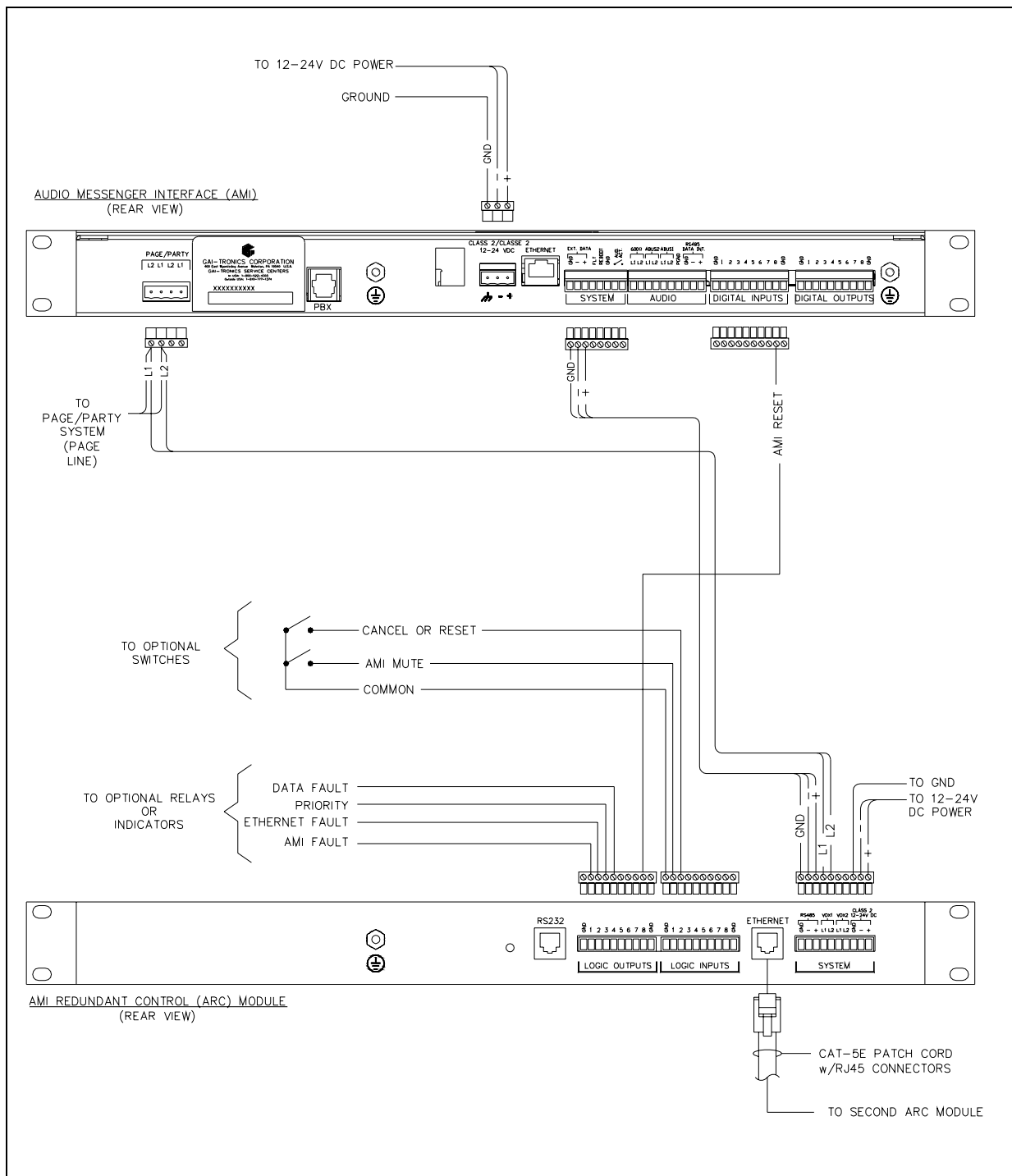

Figure 7. ARC and the 200 Series AMI Connection Diagram

System Terminals

The system terminals are used for data, audio and power connections as follows:

- RS-485** The RS-485 terminals are for a serial data connection to the AMI. This RS-485 data line allows the ARC to monitor the operating status of the AMI and control the playing of the AMI alarm tones and messages.
- Connect the RS-485 +, -, and GND terminals to the EXT DATA terminals on the AMI. Observe (-) and (+) polarity when connecting the data line. Refer to Figure 6.
- NOTE:** When using the RS-485 data connection, the RS-232 cannot be used and vice versa.
- VOX 1** The VOX 1 terminals are for sampling the audio output of the AMI. When the AMI is playing a message, these terminals verify that audio is actually being generated from the AMI. Connect the VOX 1 terminals to either the 600-ohm or 33-ohm audio output of the AMI using a twisted pair cable. Refer to Figure 6. (33-ohm audio is shown.)
- VOX 2** The VOX 2 terminals are reserved for future use. Do not make any wiring connections to these terminals.
- 12-24V DC** The 12–24 V dc terminals are used to connect power to the unit. As labeled, the ARC can operate from 12 to 24 V dc. Power the AMI from the same voltage as the ARC. Observe (-) and (+) polarity when connecting the power. Connect the GND terminal to earth ground. Refer to Figure 6.

Logic Output Terminals

The logic outputs are open collector type designed to drive externally-mounted relays or other indicating circuits. Each output can sink up to 100 mA of current when active. External circuitry (relays, indicators, etc.) must be powered from an external power supply of the same voltage used to power the ARC module (12 to 24 V dc). The ground (or dc common) terminals of the external power supply must be tied to either of the GND terminals of the ARC. The following table outlines each output's active state:

Output	Function	Notes
1	AMI Fault	This output will become active when the ARC receives an error message from the AMI; <u>or</u> when the ARC no longer detects audio on the AMI output during the playing of an alarm message or page.
2	Ethernet Fault	This output becomes active when the Ethernet/Network connection is broken between the ARC modules and they can no longer communicate with each other.
3	Priority	Under normal operation, this output is active only on the ARC module that is controlling the alarm play. If the Ethernet connection is broken between ARCs, this output will be active on both units.
4	Data Fault	This output is active when the ARC loses data communication with the AMI. This can indicate a problem with the RS-232 or RS-485 cable connection.
5	Spare	Reserved for future use.
6	Spare	Reserved for future use.
7	Spare	Reserved for future use.
8	Data Fault During Message	This output is active when the ARC loses data communication with the AMI while the AMI is playing a message. In this case, the output should be used as a "reset" input to the AMI. This resolves the issue where RS-232 or RS-485 communication is lost, and the ARC has no means to command the AMI to stop playing a message or page.

Logic Input Terminals

The logic inputs are designed to accept a normally open contact closure to stop the AMI from playing a message during an active alarm or page. The input switch contact must connect the GND terminal to the corresponding input terminal to activate. The following table outlines each input function:

Input	Function	Notes
1	AMI mute	While this input is active (switch is closed), the audio output of the AMI is muted or silenced. The input is non-latching, which means the mute is only active while the input switch is closed.
2	AMI message silence or AMI message reset	This input is programmable using the ARC's embedded web page configurator. It can be programmed as either a Silence input or Reset input. Silence input: If the AMI is playing a message, and has one or more messages in queue, and a Silence input contact is detected, the currently playing message is reset (stopped) and the next message in the queue is played. Reset input: When a Reset input contact is detected, the currently playing message and any messages in queue are reset (stopped). The Silence and Reset input are latching, which means the input switch should be momentary type contact. The factory default setting is SILENCE.
3	Spare	Reserved for future use
4	Spare	Reserved for future use
5	Spare	Reserved for future use
6	Spare	Reserved for future use
7	Spare	Reserved for future use
8	Spare	Reserved for future use

Ethernet Receptacle

A 100 Mb Ethernet connection is required between the two ARC Modules using the RJ45 receptacle. Use a cross-over CAT 5 cable between the two ARC modules if connecting them directly. If an Ethernet hub is used, connect each ARC module to the Ethernet hub using a straight pinned CAT 5 cable.

RS-232 Receptacle

The RS-232 connector is for a serial data connection to the AMI. This data line allows the ARC to monitor the operating status of the AMI and also to control playing of the AMI messages. The RS-232 data line is **DISABLED** as the factory default. Prior to using this connection, it must be enabled using the ARC's embedded web page configuration screen. An RJ11 type modular cable is connected between this connector and the accessory jack on the AMI front panel. Cable pin-out is as follows:

NOTE 1: When using the RS-485 data connection, the RS-232 cannot be used and vice versa.

NOTE 2: If the ARC and the AMI are not powered from the same source, a GND connection must be made between them for the RS-232 communication to work properly. Connect the GND connection on the Logic Inputs terminal block on the ARC to the GND connection on the Digital Inputs terminal block on the AMI.

ARC Pin No.	Function	AMI Pin No.	Notes:
1	Spare	1	
2	Data TX (to AMI)	7	
3	PTT	6	Used only when paging microphone is required for AMI.
4	Mic HI	4	Used only when paging microphone is required for AMI.
5	Mic Lo	5	Used only when paging microphone is required for AMI.
6	Spare		
7	Data RX (from AMI)	2	
8	Spare		

ADDR Hex Switch

The hex switch labeled **ADDR** is used to set the operating mode of the ARC on initial power-up. Each time the ADDR switch is changed, the unit must be restarted for the new setting to be recognized. Reset the ARC by momentarily removing power.

When the ADDR switch is set to **“0”** the ARC is the “primary” controller meaning that in normal operation, the AMI connected to it will be the “ACTIVE” alarm generator.

When the ADDR switch is set to **“1”** the ARC is the “secondary” controller meaning that in normal operation, the AMI connected to it will be the “BACK-UP” alarm generator.

All other ADDR settings (2–F) are invalid for normal operating mode and should not be selected.

Operation

LCD Display





A two-line LCD display is mounted on the front of the ARC to indicate operational status of the ARC and AMI.

The first line of the display is a text message indicating various AMI operations as follows:

Message	Meaning
AMI:RESPONDING	AMI responded with IDLE status following a status request from the ARC.
AMI:NO RESPONSE	The AMI has not responded to the status request from the ARC for 5 seconds.
AMI:PLAYING	AMI is currently playing a message or page.
AMI:MUTED	The AMI's audio output is muted, but the AMI is playing a message or a telephone page.
AMI:FAILED	The AMI has denied a request from the ARC; or the AMI has returned an unrecognizable response.
AMI:NOT READY	The AMI has returned a "Not Ready" response to a status request from the ARC.
AMI:MEDIA ERR	The AMI has returned a fault to the ARC, indicating that the Compact Flash memory card has been removed.
AMI:AUDIO ERR	The AMI has returned a fault to the ARC, indicating the AMI cannot detect audio at its internal monitoring circuit.
AMI:RS485 ERR	The AMI has returned a fault to the ARC, indicating an RS-485 communications failure with one or more modules.
AMI:DSP ERR	The AMI has returned a fault to the ARC, indicating communications with its internal digital signal processor (DSP) has stopped.

LCD Visual Indicators

The second line of the LCD display indicates if the ARC is set as the primary or secondary controller. It also displays various characters to indicate operations as follows:

Icon	Meaning
¥	This icon indicates the active ARC/AMI.
	The speaker symbol appears when the AMI is playing a message or a telephone page.
	The speaker icon turns solid when the AMI is playing a message or page but the output is muted by the ARC mute input.
	This symbol indicates a working Ethernet connection between the two ARC modules. Absence of the icon indicates an Ethernet problem.
	This symbol indicates that messages are being sent to the AMI from the ARC via the RS-232 or RS-485 connection. This symbol should flash when messages are being actively sent to the AMI and expected responses are being received from the AMI. If the ARC stops sending messages to the AMI, this symbol will no longer flash.
	This symbol indicates that messages are being sent to the ARC from the AMI via the RS-232 or RS-485 connection. This symbol should flash when recognized messages are received from the AMI. If the ARC stops receiving recognized messages from the AMI, this symbol will not be displayed.

Maintenance

ARC Diagnostics

There are two board level diagnostic tests available that are enabled by setting the ADDR switch. The top cover must be removed from the ARC module to allow the test LEDs to be observed.

VOX Input Test

When ADDR switch is set to “A,” followed by a board reset, the LCD will show DIAG: VOX INPUT. This indicates that the ARC board is in diagnostic mode for the VOX1 and VOX2 inputs.

When audio is detected on VOX1, LED 3 on the PCBA illuminates. LED 3 turns off when audio is no longer detected at the VOX1 input. Likewise, when audio is detected on VOX2 input, LED 4 illuminates. LED 4 turns off when audio is no longer detected at the VOX2 input.

Input/Output (Switch B)

When ADDR switch is set to “B,” followed by a board reset, the LCD will show DIAG: I/O. This indicates that the ARC board is in the diagnostic mode for testing the inputs and outputs.

When Input 1 is activated, Output 1 will be activated. When Input 2 is activated, Output 2 will be activated, etc. This sequence is true for Input 1 through Input 8.

ARC Embedded Web Page

The ARC contains an embedded web server, which can be used for altering some of the unit's factory default settings. The IP address of the unit depends on the setting of the ADDR switch.

- When the ADDR switch is set to “0” the ARC is the Primary controller and the IP address is 192.168.1.151
- When the ADDR switch is set to “1” the ARC is the Secondary controller and the IP address is 192.168.1.152

Connect a computer to the Ethernet plug of the ARC using a crossover CAT5 network cable. Using Internet Explorer open the ARC webpage by typing in the correct IP address listed above. The following screen display is an example of the web page for the Primary Controller.

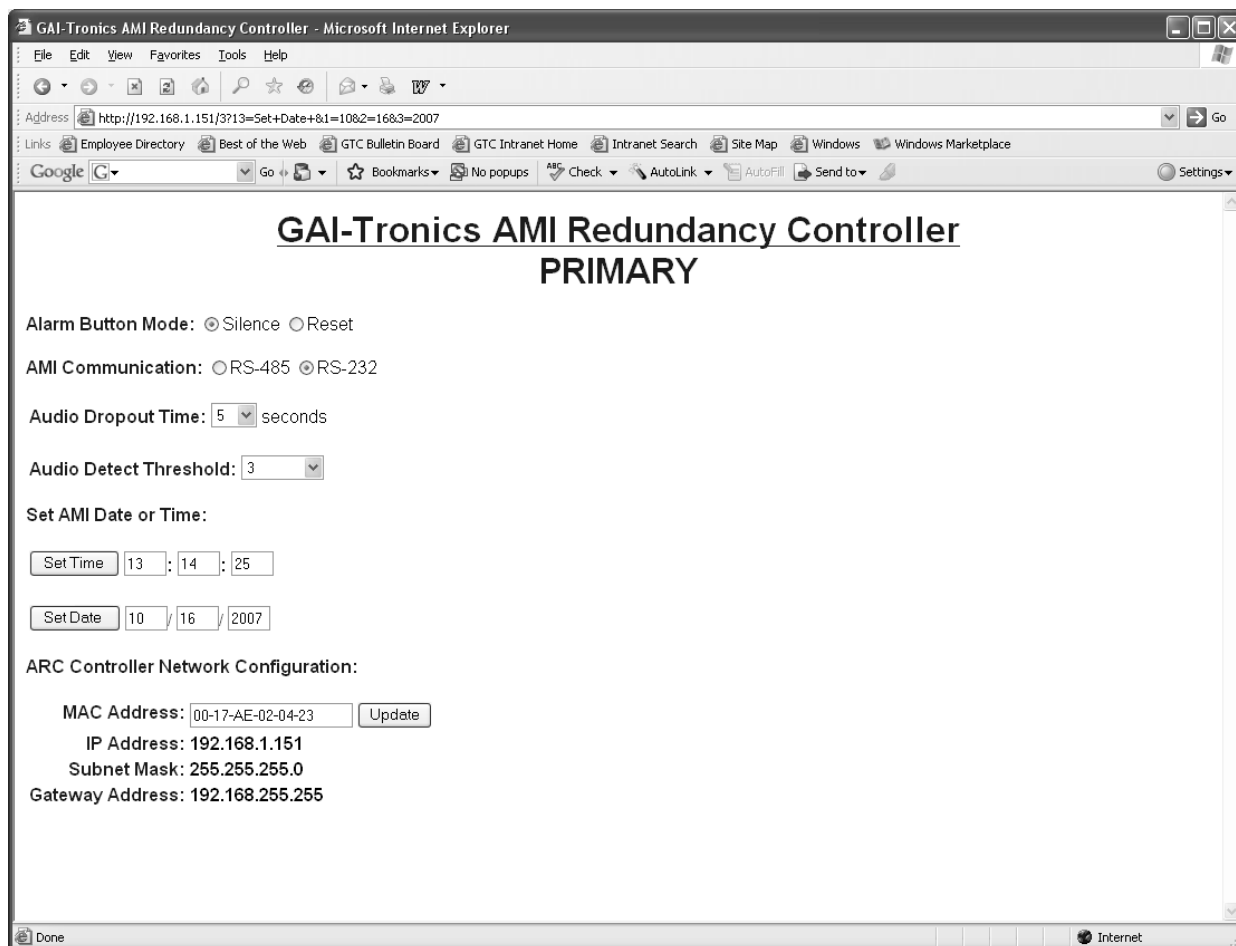

The following functions may be changed using the web-page.

Function	Meaning
Alarm Button Mode	<p>These radio buttons select the mode assigned to Input 2.</p> <p>Selecting Silence mode will cause the AMI to stop playing its current message or page when the button is pressed.</p> <p>Reset mode will cause the AMI to clear all of its alarms and pages when the button is pressed.</p>
AMI Communication	<p>This button is used to select the communication interface between the ARC Board and the AMI (RS-232 or RS-485). RS-485 is the default communication interface. After changing this value, the ARC board MUST be reset. The web page must be refreshed following the board reset.</p>
Audio Dropout Time	<p>Assuming no audio is detected at the VOX 1 input, this setting value determines the length of time (in seconds) before the ARC reports a “No Audio” condition and switches control to the back-up AMI. The range is 5–10 seconds in 1-second increments. The default value is 5 seconds. This parameter may need to be altered if there are pause (silence) times in the AMI message greater than 5 seconds.</p>
Audio Detect Threshold	<p>This setting specifies the threshold level at which the audio is detected by the ARC board. Selecting the Disable option from the drop-down list will disable audio detection. Valid values for audio detection are 1 through 10, ranging from 100 mV to 1 V, in steps of 100 mV. The default value of this parameter is 3 (300 mV).</p>
Set AMI Date or Time	<p>Allows the user to change the date and time on the corresponding AMI. NOTE: This is the only way to set the date/time on the AMI, and must be done separately for each ARC board. The default web page values for date and time are set according to the last date/time retrieved from the AMI. The data connection to the AMI must be functioning properly to allow the date and time to be set.</p>
ARC Controller Configuration	<p>Displays the network configuration data for the ARC board:</p> <ul style="list-style-type: none"> • Current MAC address • Current IP address • Subnet mask • Gateway address <p>These values cannot be modified via the web page.</p>

AMI Configuration Requirements

The following parameters must set:

- The **Advance Control** must be enabled on the Global parameter tab.
- **Input 8** must be **Maintained - Normally Open** switch type, and the **Clear All** function must be selected. This AMI Input 8 should be wired to Output 8 on the ARC. This input causes the ARC to reset the AMI message in the event that data communication is lost while an alarm is active.

All other settings regarding the AMI configuration can be project specific.

Specifications

Power Supply Requirements

Connection to a 12 to 24 V dc (UL-listed) Class 2 power source..... 0.2 amps minimum

Power consumed 2 watts maximum

Electrical

Logic outputsSink 100 mA per output to circuit common and must be powered from an external power supply of the same voltage as the ARC module

Mechanical

Enclosure Steel body and cover, black fine-textured paint finish

Mounting..... Rack-mount, IU Standard, 19-inch

Dimensions 19.00 W × 5.30 D × 1.75 H inches (431 × 135 × 44 mm) nominal

Weight..... 5 lbs.

Environmental

Temperature range +32° F to +122° F (0° C to +50° C)

Warranty

Equipment. GAI-Tronics warrants for a period of one (1) year from the date of shipment, that any GAI-Tronics equipment supplied hereunder shall be free of defects in material and workmanship, shall comply with the then-current product specifications and product literature, and if applicable, shall be fit for the purpose specified in the agreed-upon quotation or proposal document. If (a) Seller's goods prove to be defective in workmanship and/or material under normal and proper usage, or unfit for the purpose specified and agreed upon, and (b) Buyer's claim is made within the warranty period set forth above, Buyer may return such goods to GAI-Tronics' nearest depot repair facility, freight prepaid, at which time they will be repaired or replaced, at Seller's option, without charge to Buyer. Repair or replacement shall be Buyer's sole and exclusive remedy. The warranty period on any repaired or replacement equipment shall be the greater of the ninety (90) day repair warranty or one (1) year from the date the original equipment was shipped. In no event shall GAI-Tronics warranty obligations with respect to equipment exceed 100% of the total cost of the equipment supplied hereunder. Buyer may also be entitled to the manufacturer's warranty on any third-party goods supplied by GAI-Tronics hereunder. The applicability of any such third-party warranty will be determined by GAI-Tronics.

Services. Any services GAI-Tronics provides hereunder, whether directly or through subcontractors, shall be performed in accordance with the standard of care with which such services are normally provided in the industry. If the services fail to meet the applicable industry standard, GAI-Tronics will re-perform such services at no cost to buyer to correct said deficiency to Company's satisfaction provided any and all issues are identified prior to the demobilization of the Contractor's personnel from the work site. Re-performance of services shall be Buyer's sole and exclusive remedy, and in no event shall GAI-Tronics warranty obligations with respect to services exceed 100% of the total cost of the services provided hereunder.

Warranty Periods. Every claim by Buyer alleging a defect in the goods and/or services provided hereunder shall be deemed waived unless such claim is made in writing within the applicable warranty periods as set forth above. Provided, however, that if the defect complained of is latent and not discoverable within the above warranty periods, every claim arising on account of such latent defect shall be deemed waived unless it is made in writing within a reasonable time after such latent defect is or should have been discovered by Buyer.

Limitations / Exclusions. The warranties herein shall not apply to, and GAI-Tronics shall not be responsible for, any damage to the goods or failure of the services supplied hereunder, to the extent caused by Buyer's neglect, failure to follow operational and maintenance procedures provided with the equipment, or the use of technicians not specifically authorized by GAI-Tronics to maintain or service the equipment. **THE WARRANTIES AND REMEDIES CONTAINED HEREIN ARE IN LIEU OF AND EXCLUDE ALL OTHER WARRANTIES AND REMEDIES, WHETHER EXPRESS OR IMPLIED BY OPERATION OF LAW OR OTHERWISE, INCLUDING ANY WARRANTIES OF MERCHANTABILITY OR FITNESS FOR A PARTICULAR PURPOSE.**

Return Policy

If the equipment requires service, contact your Regional Service Center for a return authorization number (RA#). Equipment should be shipped prepaid to GAI-Tronics with a return authorization number and a purchase order number. If the equipment is under warranty, repairs or a replacement will be made in accordance with the warranty policy set forth above. Please include a written explanation of all defects to assist our technicians in their troubleshooting efforts.

Call 800-492-1212 (inside the USA) or 610-777-1374 (outside the USA) for help identifying the Regional Service Center closest to you.