



**GAI-TRONICS®**  
A HUBBELL COMPANY

# Model 379-001 Monitored Relay Module (MRM) Station

---

## Confidentiality Notice

This manual is provided solely as an installation, operation, and maintenance guide, which contains sensitive business and technical information, that is confidential and proprietary to GAI-Tronics. GAI-Tronics retains all intellectual property and other rights in or to the information contained herein, and such information may only be used in connection with the operation of your GAI-Tronics product or system. This manual may not be disclosed in any form, in whole or in part, directly or indirectly, to any third party.

## General Information

The Model 379-001 Monitored Relay Module (MRM) Station is used in SmartSeries ADVANCE Systems. Operation is controlled by the system's Master Control Unit (MCU) programming.

The MRM provides eight relay output circuits. Each relay contains two type "C" contacts rated for 5 amps. Relay outputs are typically used for switching power to signaling devices such as beacons or strobes but can be used for any switching application that does not exceed the relay's current rating. Relay circuits can be programmed to activate during system alarms, pages, or trouble conditions.

The MRM also contains eight input circuits. Input circuits can be used supervise the cable integrity connecting the relay output to the signaling device (as described above). During an inactive state, the cable is monitored for open circuit, short circuit and ground fault conditions. If a cable fault is detected, the relay circuit will not activate, preventing a possible dangerous condition. Fault conditions are automatically reported to the MCU.

For each relay circuit not requiring supervision, one input circuit is available for other functions. Inputs are activated by a voltage-free contact (either opening or closing) or the presence/absence of a 24 V dc input voltage. When using inputs from voltage-free contacts, the MRM can supervise the cabling between the input terminal and the remote contact closure device. The cable is monitored for open circuit, short circuit and ground fault conditions. Fault conditions are automatically reported to the MCU.

Each input circuit can be programmed to initiate one of the following functions in the ADVANCE System.

- Activate an alarm
- Reset all alarms
- Cancel the current alarm
- Report a fault condition
- Reset the system MCU

Model 379-001 Monitored Relay Module (MRM) Station

The Model 379-001 Monitored Relay Module (MRM) Station components are housed in a NEMA 4X stainless steel enclosure measuring 13.0 W × 14.3 H × 6.23 D inches (330.2 × 363.2 × 158.2 mm). Components include a 12 V dc power supply, a 12579-003 Monitored Relay Module, and two terminal blocks.

The 12579-003 Monitored Relay Module is comprised of three components: the 69613-001TR CPU, the 69251-201TR Monitored-Input PCBA, and the 69252-001TR Relay PCBA. Refer to Figure 1 for component locations.

The scope of this manual is limited to mounting and wiring connections for the Model 379-001 Station. Refer to Pub. 42004-716L2 for additional information on the 12579-003 Monitored Relay Module.

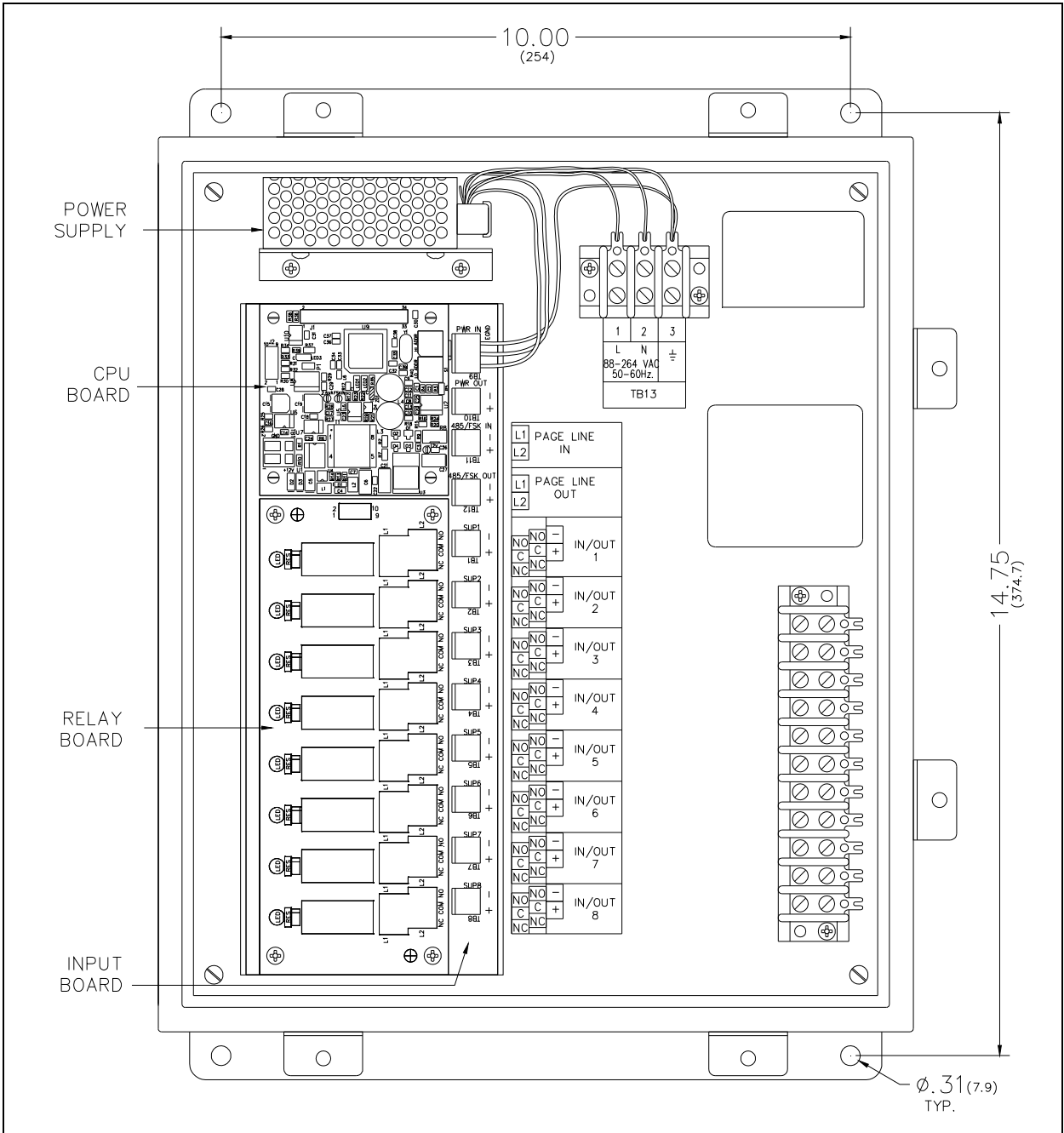

Figure 1. Model 379-001 MRM Station (Interior View)

# Installation

**⚠ CAUTION ⚠** Do not install this equipment in hazardous areas other than those indicated on the approval listing in the “Specifications” section of this manual. Such installation may cause a safety hazard and consequent injury or property damage. Disconnect power before installing or removing the MRM.

## Mounting

The Model 379-001 MRM Station enclosure is not supplied with conduit or cable gland holes since cable quantity, size, and entry location vary with each installation.

Drill or punch openings at the required locations before mounting the enclosure. Typically, multiple cable entries are required for SmartSeries Page/Party<sup>®</sup> system cable and input wiring. Refer to the Wiring section below. Use caution when drilling or punching the enclosure to avoid damaging the internal components. Bottom cable entry is recommended to prevent moisture from entering the enclosure and dripping onto the terminals or circuit boards.

Mount the enclosure to a suitable surface using appropriate customer-supplied hardware. Refer to Figure 1 for mounting hole dimensions.

Remove the shipping tie-wrap that is securing the PCBA to its mounting snaptrack.

## Wiring

The MRM Station is wired in parallel to the Page/Party<sup>®</sup> system cable in the same fashion as SmartSeries handset/speaker stations. The system cable distributes ac power, party line audio and a page line to the stations. The MRM requires only ac power and page line connections from the system cable. Spare terminals are provided for the unused conductors in the system cable. A separate cable(s) is generally used for the input connections. Each connection is explained below.

### Power

88 V ac to 264 V ac power is connected to terminal block TB13 at the top of the panel. Refer to Figure 1. AC power is accessed from the Page/Party<sup>®</sup> system cable per the following table.

Function	Terminal Block	System Cable Wire Color
AC Line (hot)	TB13-1	Black
Neutral	TB13-2	White
Ground	TB13-3	Green/yellow

Page Line

The page line twisted pair in the Page/Party<sup>®</sup> system cable serves as the data line between the MRM and the ADVANCE system control cabinet. The page line connections are made to the MRM module per the following table. Refer to Figure 1 for terminal locations.

Function	MIM Terminal Block	System Cable Wire Color
Page Line (L1)	TB 11 (L1)	Red/blue
Page Line (L2)	TB 11 (L2)	Blue/red

Inputs

Input connections (from voltage-free contacts or switched 24 V dc voltage sources) are made to screw terminals TB1 through TB8 on the input PCBA. Refer to Figure 1 for terminal locations.



To ensure proper termination, ferrules should be crimped on the end of all input wires prior to connecting to the MRM terminal blocks. The terminal blocks accept No. 28 to No. 12 AWG conductors.

Each input is wired to operate in one of five input configurations (modes) that is set via system programming. Each mode requires a unique connection scheme between the external field device and the corresponding input terminals on the MRM. The connection scheme for each input mode is described below. Since each input operates independently, only input one will be discussed. Inputs two through eight are identical.

**Mode 0: Deactivate Circuit**

The input circuit is disabled via system programming. No external connections may be made to connector TB1.

**Mode 1: IDC Line Supervision (Multiple Switches)**

In this mode, any number of normally open voltage-free contact closures may be installed on the input line and a 20-kilohm resistor must be installed across the last contact. The cable is monitored for ground faults and open circuits. When the contacts are inactive (open), the line appears as 20-kilohm load. This indicates a healthy inactive cable loop.

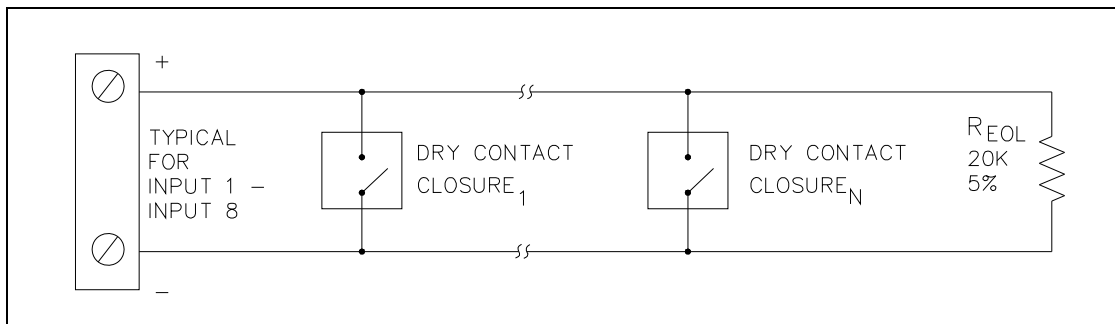

Figure 2. Multiple normally-open switches

When any contact is closed, the 20-kilohm resistor is bypassed. The input circuit is shorted, indicating an active input.

If either cable leg is grounded, or if a cable break occurs on either leg, the 20-kilohm load is removed indicating a fault condition.

**NOTE:** The 20-kilohm, 5% tolerance resistor is not included with the MRM. This resistor is included in the Model 12509-003 Kit, which is sold separately.

**Mode 2: IDC Single Normally-Open (N.O.) Switch**

In this configuration, only one normally open voltage-free contact closure may be installed and a 5.1-kilohm and 15-kilohm resistor must be wired in series/parallel with the contact. The cable is monitored for open circuits, wire-to-wire short circuits (across + and -), and ground faults. When the contact is inactive (open), the line appears as 20.1-kilohm load (15 kilohms in series with 5.1 kilohms). This indicates a healthy inactive cable loop.

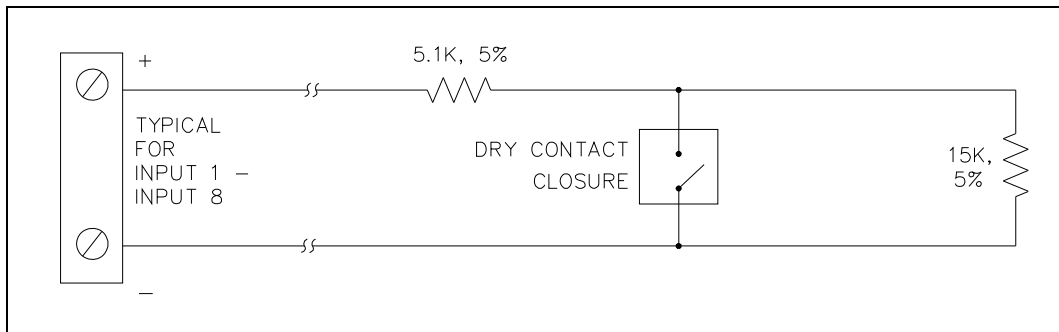

Figure 3. Single normally-open switch

When the contact closed, the 15-kilohm resistor is bypassed. The circuit then sees only the 5.1-kilohm load, indicating an active input.

If there is a short across + and -, if either cable leg is grounded, or if a cable break occurs on either leg, the 20-kilohm load is removed indicating a fault condition.

**NOTE:** The terminating resistors are not included with the MRM. These resistors are included in the Model 12509-003 Kit, which is sold separately.

**Mode 3: IDC Single Normally-Closed (N.C.) Switch**

In this configuration, only one normally closed voltage-free contact may be installed and a 5.1-kilohm and 15-kilohm resistor must be wired in series/parallel with the contact. The cable is monitored for open circuits, wire-to-wire short circuits (across + and -), and ground faults. When the contact is closed, the 15-kilohm resistor is bypassed and the circuit sees only the 5.1-kilohm load. This indicates a healthy inactive cable loop.

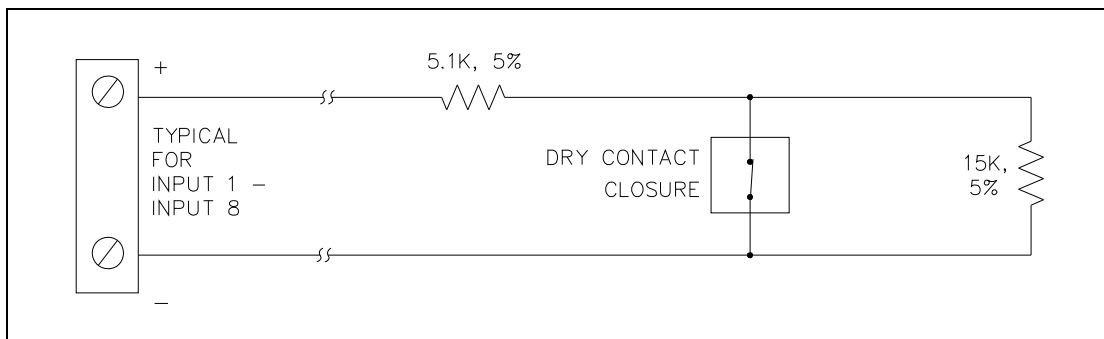

Figure 4. Single normally-closed switch

When the contact opens, the circuit then sees a 20.1-kilohm load (15 kilohms in series with 5.1 kilohms), indicating an active input.

If there is a short across + and -, if either cable leg is grounded, or if a cable break occurs on either leg, the 20.1-kilohm load is removed indicating a fault condition.

**NOTE:** The terminating resistors are not included with the MRM. These resistors are included in the Model 12509-003 Kit, which is sold separately.

**Mode 4: IAC Line Supervision**

In this mode, multiple strobe lights may be installed across the common relay terminals. Total strobe current draw cannot exceed 5 amps. A 20-kilohm 2-watt resistor must be installed across the last strobe. The strobe power source is connected to the normally open relay terminals. The normally closed relay terminals are connected to the corresponding input terminals. (Relay 1 to Input 1, Relay 2 to Input 2, etc.) Refer to Figure 5 and Figure 6 below.

During an inactive condition, the input circuit monitors the strobe cable for open circuits, short circuits and ground faults. Under normal conditions the line appears as 20-kilohm load, indicating a healthy cable loop.

During an active condition, the relay contacts change state. The input circuit is isolated from the strobe cable and power is applied to activate the strobes. The cable loop is not monitored during active relay conditions.

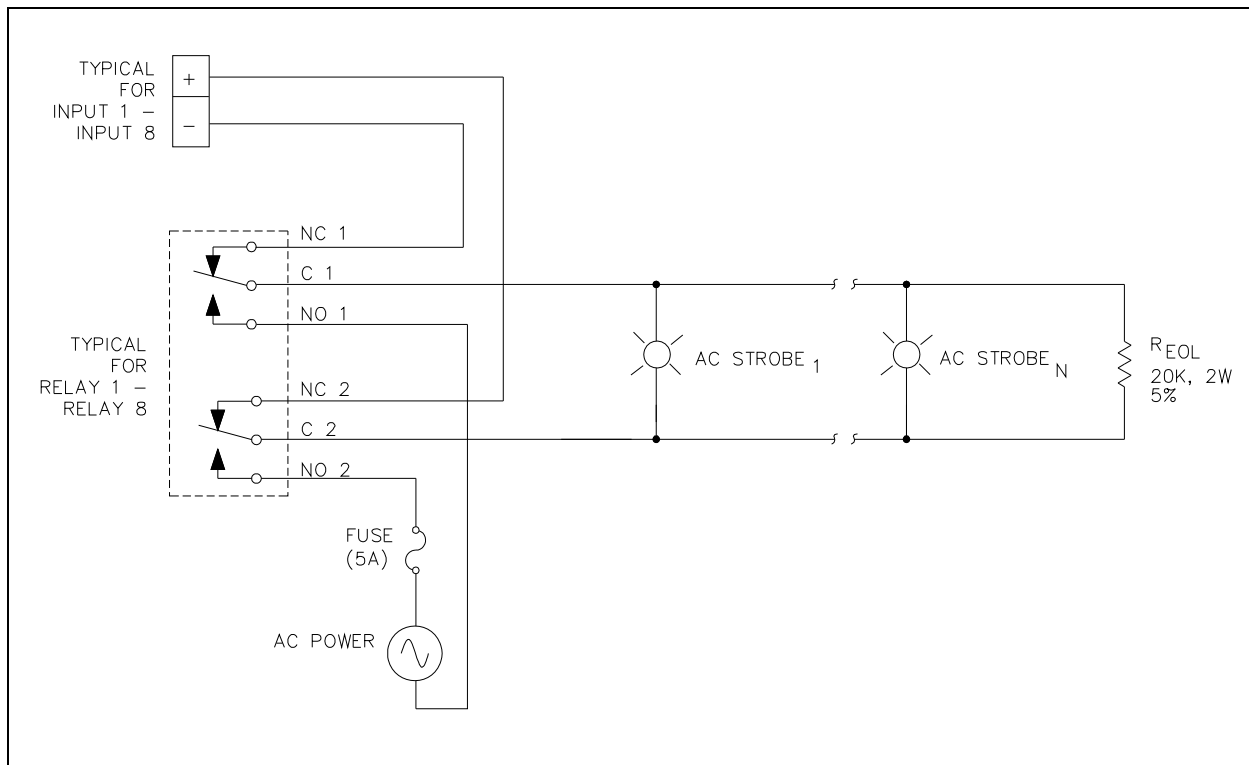

Figure 5. Cable supervision for ac-powered strobes

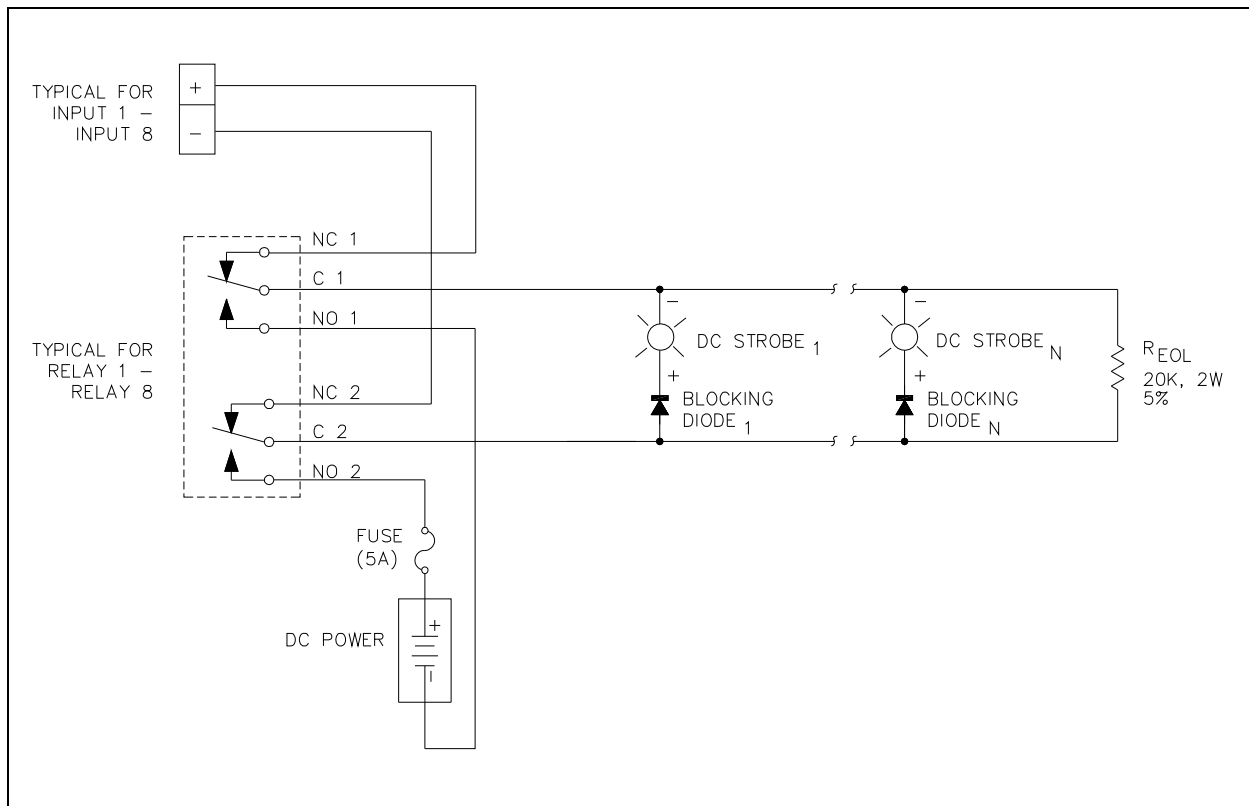

Figure 6. Cable supervision for dc-powered strobes

**Mode 5: IDC Non-Supervision Multiple Switch (Voltage-free Contact)**

In this mode, any number of normally open dry contact closures can be installed on the line. No end-of-line resistors are installed. The cable loop is not monitored for any faults.

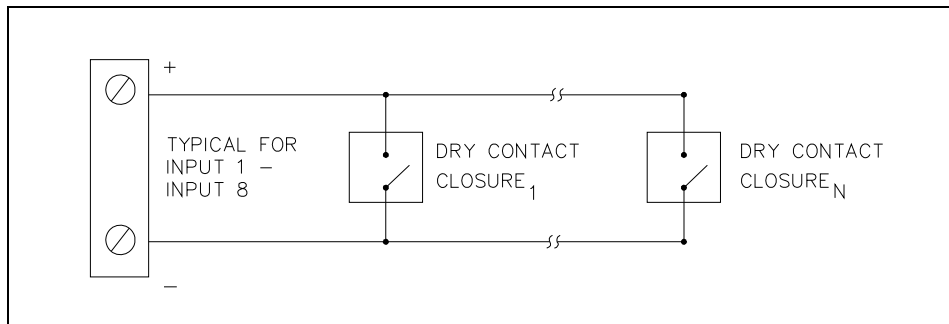

Figure 7. Non-Supervision Multiple Switches

When the contact is open the circuit is inactive, and when the contact is closed, the circuit is active.

**Mode 5: IDC Non-Supervision (24 V DC)**

In this mode, a 24 V dc voltage source can be installed on the line. No end-of-line resistors are installed. The cable loop is not monitored for any faults.

Shorting jumpers (located next to the input terminals) must be moved from the factory default of “dry” to “wet” contact mode.

When set to “wet” contact mode, the input can be activated during a 0 V condition or a 24 V condition depending on the “active” jumper position. The factory default setting is “24 V dc input when active” (position 2-3). If “0 V dc input when active” is desired, move jumper from position 2-3 to position 1-2.

Ensure the polarity of input connection is correct as it is polarity sensitive.

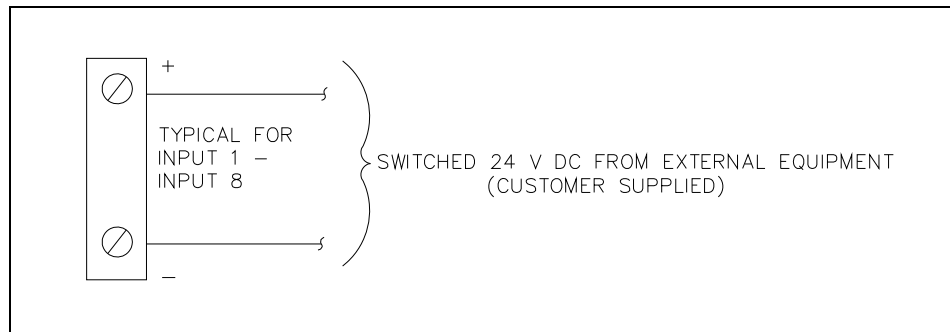

Figure 8. Non-Supervision (wet contact)

### Relay Outputs

Field wiring connections are made to the screw terminals on the relay PCBA. Eight relays are available; each contains two type “C” contacts rated for 5 amps. The normally open (NO), common (C), and normally closed (NC) terminals are labeled on the relay PCBA. Refer to Figure 1 for terminal locations. Refer to Figure 5 for a typical beacon light connection diagram.

To ensure proper termination, ferrules must be crimped on the ends of all input wires prior to connecting them to the relay terminal blocks. The terminal blocks can accept No. 28 AWG to No.12 AWG conductors.

### Setting the Station Address

Each station connected to the Page/Party<sup>®</sup> system cable requires a unique address. Valid address settings are hexadecimal numbers 05 through FE. The address for each station is determined by the system programming.

Two hexadecimal switches located on the MIM CPU Board set the station address. The address consists of a low address setting and high address setting. Each switch contains 16 settings, labeled 0–F. The MRM station’s address is determined by the high address setting followed by the low address setting.

For example, to assign an address of **05**, the high address is set to **0** and the low address is set to **5**.



# Specifications

## Electrical

Power requirements .....88 V ac to 264 V ac, 50/60 Hz, 0.87 A maximum

**NOTE:** Power requirements do NOT include power switched to external devices such as strobe lights.

## Mechanical

Enclosure material ..... No. 16 gauge, 316 stainless steel

Dimensions ..... 13.0 W × 14.3 H × 6.23 D in (330.2 × 363.2 × 158.2 mm)

Weight..... 19 lb

## Environmental

Humidity ..... 95% non-condensing relative humidity

Temperature range ..... -22 °F to 158 °F (-30 °C to 70 °C)

Environmental rating ..... NEMA 4X

# Replacement Parts

Part Number	Description
69613-001TR	PCBA, CPU Module with FSK
69251-201TR	PCBA, Monitored-In-8
69252-001TR	PCBA, Relay Module
40404-009	Power Supply, 12 V dc, 25W

# References

For additional information, please refer to the standard publication listed below.

42004-716L2..... Model 12579-003 Monitored Relay Module (MRM) Manual

# Warranty

---

Equipment. GAI-Tronics warrants for a period of one (1) year from the date of shipment, that any GAI-Tronics equipment supplied hereunder shall be free of defects in material and workmanship, shall comply with the then-current product specifications and product literature, and if applicable, shall be fit for the purpose specified in the agreed-upon quotation or proposal document. If (a) Seller's goods prove to be defective in workmanship and/or material under normal and proper usage, or unfit for the purpose specified and agreed upon, and (b) Buyer's claim is made within the warranty period set forth above, Buyer may return such goods to GAI-Tronics' nearest depot repair facility, freight prepaid, at which time they will be repaired or replaced, at Seller's option, without charge to Buyer. Repair or replacement shall be Buyer's sole and exclusive remedy. The warranty period on any repaired or replacement equipment shall be the greater of the ninety (90) day repair warranty or one (1) year from the date the original equipment was shipped. In no event shall GAI-Tronics warranty obligations with respect to equipment exceed 100% of the total cost of the equipment supplied hereunder. Buyer may also be entitled to the manufacturer's warranty on any third-party goods supplied by GAI-Tronics hereunder. The applicability of any such third-party warranty will be determined by GAI-Tronics.

Services. Any services GAI-Tronics provides hereunder, whether directly or through subcontractors, shall be performed in accordance with the standard of care with which such services are normally provided in the industry. If the services fail to meet the applicable industry standard, GAI-Tronics will re-perform such services at no cost to buyer to correct said deficiency to Company's satisfaction provided any and all issues are identified prior to the demobilization of the Contractor's personnel from the work site. Re-performance of services shall be Buyer's sole and exclusive remedy, and in no event shall GAI-Tronics warranty obligations with respect to services exceed 100% of the total cost of the services provided hereunder.

Warranty Periods. Every claim by Buyer alleging a defect in the goods and/or services provided hereunder shall be deemed waived unless such claim is made in writing within the applicable warranty periods as set forth above. Provided, however, that if the defect complained of is latent and not discoverable within the above warranty periods, every claim arising on account of such latent defect shall be deemed waived unless it is made in writing within a reasonable time after such latent defect is or should have been discovered by Buyer.

Limitations / Exclusions. The warranties herein shall not apply to, and GAI-Tronics shall not be responsible for, any damage to the goods or failure of the services supplied hereunder, to the extent caused by Buyer's neglect, failure to follow operational and maintenance procedures provided with the equipment, or the use of technicians not specifically authorized by GAI-Tronics to maintain or service the equipment. **THE WARRANTIES AND REMEDIES CONTAINED HEREIN ARE IN LIEU OF AND EXCLUDE ALL OTHER WARRANTIES AND REMEDIES, WHETHER EXPRESS OR IMPLIED BY OPERATION OF LAW OR OTHERWISE, INCLUDING ANY WARRANTIES OF MERCHANTABILITY OR FITNESS FOR A PARTICULAR PURPOSE.**

## Return Policy

---

If the equipment requires service, contact your Regional Service Center for a return authorization number (RA#). Equipment should be shipped prepaid to GAI-Tronics with a return authorization number and a purchase order number. If the equipment is under warranty, repairs or a replacement will be made in accordance with the warranty policy set forth above. Please include a written explanation of all defects to assist our technicians in their troubleshooting efforts.

Call 800-492-1212 (inside the USA) or 610-777-1374 (outside the USA) for help identifying the Regional Service Center closest to you.