



**GAI-TRONICS®**  
A HUBBELL COMPANY

# Model 12578-003

## Monitored Input Module (MIM)

---

### Confidentiality Notice

This manual is provided solely as an operational, installation, and maintenance guide and contains sensitive business and technical information that is confidential and proprietary to GAI-Tronics. GAI-Tronics retains all intellectual property and other rights in or to the information contained herein, and such information may only be used in connection with the operation of your GAI-Tronics product or system. This manual may not be disclosed in any form, in whole or in part, directly or indirectly, to any third party.

### How to Use the Assembly/Model

#### Application

The 12578-003 Monitored Input Module (MIM) is used in SmartSeries ADVANCE systems. GAI-Tronics uses the MIM to receive inputs from field devices, monitor the integrity of eight input lines for trouble conditions or contact activation, and report these conditions to the 69254 Series or 69440 Series Master Control Unit (MCU). The MIM is comprised of two components: the 69613-001 Central Processing Unit (CPU) printed circuit board assembly (PCBA) and the 69251-201 Monitored-In-8 PCBA.

The MIM is designed to be mounted in a Snaptrack that is installed inside an enclosure. Snaptrack is a grooved plastic channel that is designed to allow PCBAs to securely 'snap' into the groove. The Snaptrack provides flexible installation because the track may be installed inside an enclosure wherever it is convenient.

The module communicates with the MCU via the 69613-001 CPU PCBA over a FSK modem intended for use in GAI-Tronics SmartSeries systems. The CPU PCBA interprets and reports the status of the inputs. The MIM is capable of monitoring up to eight inputs. The MCU identifies a particular MIM on the page line (FSK link) by its module address. This module address is set by rotary hex switches S1 and S2 of the MIM (located on the CPU PCBA.) The range of valid settings is from 05 to FE (hex).

Each input may be independently configured to operate in one of the following five modes:

Input Mode	Description	Comments
0	Deactivate circuit	Input is not monitored.
1	IDC line supervision multiple switch	Detects open circuit, ground faults, and switch actuation from one or more normally-open dry contact closures.
2	IDC single N.O. switch	Detects open circuit, wire-to-wire short circuit, ground faults, and switch actuation from a single normally-open dry contact closure.
3	IDC single N.C. switch	Detects open circuit, wire-to-wire short circuit, ground faults, and switch actuation from a single normally-closed dry contact closure.
4	IAC line supervision	Reserved for 12579-003 Monitored Relay Module
5	IDC non-supervised N.O. dry switch	Detects a switch actuation from one or more normally-open dry contact closures.
5	IDC non-supervised, wet switch	Detects the presence or absence of 24 V dc voltage depending on applicable onboard jumper settings.

In order to utilize a particular input mode with a particular input, the appropriate external connections must be made between the MIM and the field devices. Also, the input modes must be added to the MCU Configuration using the ADVANCE Console System Configuration Software. Refer to the "Installation Guidelines" section on page 4 for further details.

## Hardware Configuration

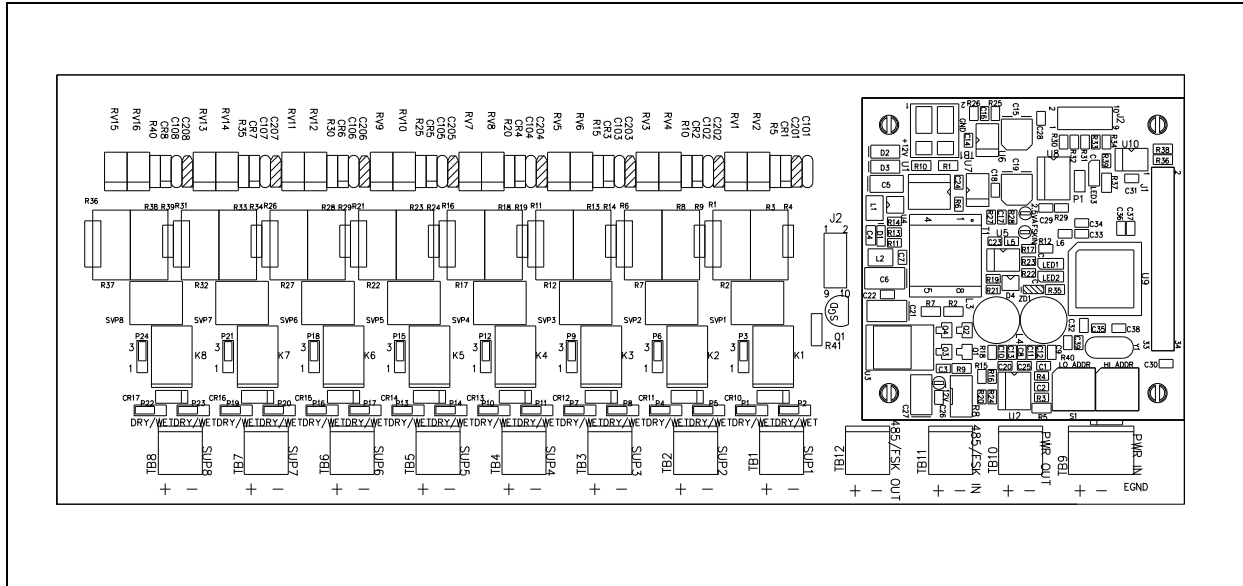

Figure 1. Model 12578-003 Monitored Input Module

## Interfaces

The Model 12578-003 Monitored Input Module interfaces to a Page/Party<sup>®</sup> Interface (PPI) card in the ADVANCE control cabinet via the system page line (FSK link).

## Installation Safety Guidelines

Please adhere to all warnings, safety, and operating instructions on the unit and in the installation manual.



- Disconnect power before servicing
- Do not disconnect equipment while circuit is energized.
- Avoid servicing the unit during electrical storms.
- Do not touch uninsulated wires.

## Installation Guidelines

1. Notify plant personnel of a system shutdown prior to servicing the unit.
2. Disconnect power before installing or removing the MIM.

### Mounting



Warning: Observe precautions for handling electrostatic sensitive devices.

To install the module into the Snaptrack slide either the right or the left edge of the module into the top groove on the track. On the opposite side, press firmly on the top and bottom corners of the module until they snap into the groove. Carefully press from each corner toward the center and simultaneously snap the edge firmly into place.

### Power

After the PCBA is installed onto the Snaptrack, 12 V dc power is brought in from the auxiliary power supply and terminated on TB9 (PWR IN). The positive leg is connected to TB9-1 (+) and the return leg is landed on TB9-2 (-). An earth ground is connected to TB9-3 (EGND). TB9 is paralleled with TB10. TB10 (PWR OUT) may be used to distribute power to additional Snaptrack modules.

### NOTES:

- Although power may be daisy-chained between MIMs and other Snaptrack modules, the preferred method of delivering power to these modules is by providing a dedicated cable run between each module and the auxiliary power supply.
- The auxiliary power supply return leg must be connected to earth ground for proper operation. The physical connection should be made at the auxiliary power supply terminals.
- The ground reference for this assembly must be identical to that of the enclosure.
- The MIM does not contain any current-limiting for power. It is recommended that an external fuse be provided with the appropriate voltage and current ratings. The selected fuse should be of the slo-blo variety.

### Data Communication Line

Terminal blocks TB11 and TB12 are for the page line connection (FSK data communication) from the PPI card and to additional MIM and MRM modules.

**NOTE:** The conductor terminated on TB12 should be a twisted pair.

### FSK Signal Gain

The FSK Signal Gain, R8, adjusts the FSK transmit signal strength. It is set at the factory and should not be adjusted by the installer.

## Inputs

The MIM contains eight individually configurable inputs, allowing it to interface with field devices. Connections with these field devices are made at connectors TB1 through TB8. Each connector corresponds to a single input (TB1 is used for input #1, TB2 is used for input #2, etc.) Each one of these inputs may be configured to operate in one of five input modes.

Each input mode requires a unique connection scheme between the external field devices and the appropriate input connector on the MIM. The connection scheme for each input mode is indicated below. Since the connection scheme is independent of which input is used, only input #1 will be discussed.

**NOTE:** To ensure proper termination, ferrules must be crimped on the end of all conductors that are terminated on the terminal blocks. The size of the ferrule is dependent upon the size of the conductor used and may be sourced from any supplier such as Phoenix, Altec or Weidmuller. The terminal blocks may accept conductors between sizes No. 28 AWG to 12 AWG.

### Mode 0: Deactivate Circuit

In this mode, input #1 is not used and is not monitored by the MIM. If this mode is used, **no external connections** should be made to connector TB1.

### Mode 1: IDC Line Supervision Multiple Switch

In this mode any number of normally-open dry contact closures may be installed on the line. The loop is monitored for ground faults and open circuits in Mode 1. The end-of-line device is a 20 k $\Omega$ , 5% tolerance resistor.

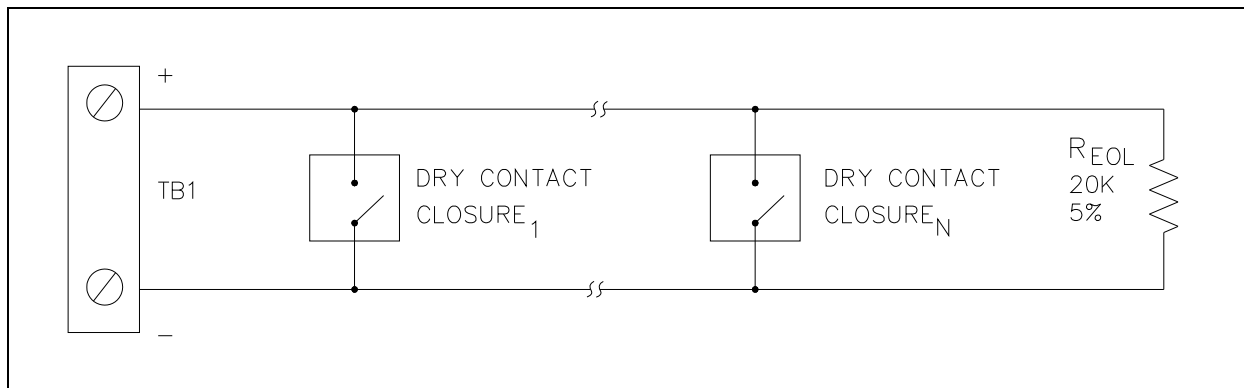

Figure 2. IDC Line Supervision Multiple Switch

**NOTE:** The 20 k $\Omega$ , 5% tolerance resistor is not included with the MIM. This resistor is included in a kit (12509-003), which must be ordered separately.

## Model 2: IDC Single Normally-Open (N.O.) Switch

In this configuration, only one normally-open dry contact closure may be installed per supervised line. In this mode, the loop is monitored for open circuits, wire-to-wire short circuits (across + and -), and ground faults. When the contact closure is not active (open), the loop appears as 20.1 k $\Omega$  load (15 k $\Omega$  in series with 5.1 k $\Omega$ ). This appears on the input to the MIM and indicates a healthy loop. When the contact closure is active (closed), the 15 k $\Omega$  resistor is bypassed.

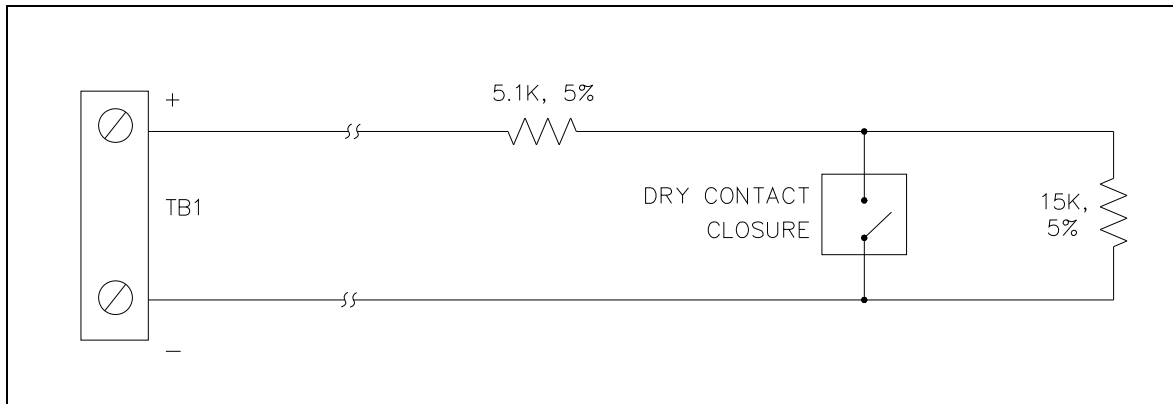

Figure 3. IDC Single Normally-Open Switch

The circuit then sees only the 5.1 k $\Omega$  load. This changes the value of the input and indicates to the MIM that the contact closure is active. If there is a short across + and -, if either leg is grounded, or if a break occurs on either leg, the MIM indicates that a fault has occurred.

**NOTE:** The terminating resistors are not included with the MIM. These resistors are included in a kit (12509-003) that must be ordered separately.

### Mode 3: IDC Single Normally-Closed (N.C.) Switch

In this configuration, only one normally-closed dry contact closure may be installed per supervised line. In this mode, the loop is monitored for open circuits, wire-to-wire short circuits (across + and -), and ground faults. When the contact closure is not active (closed), the 15 k $\Omega$  is bypassed and the circuit sees only the 5.1 k $\Omega$  load.

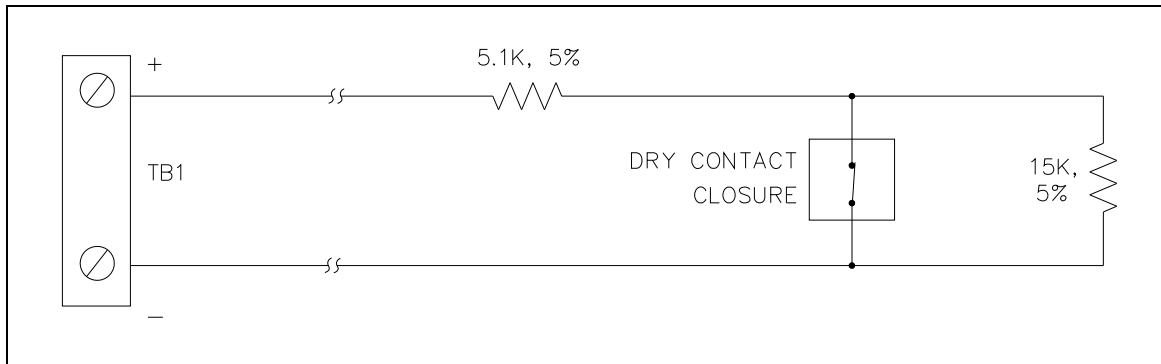

Figure 4. IDC Single Normally-Closed Switch

When the contact closure is active (open), the loop appears as a 20.1 k $\Omega$  load (15 k $\Omega$  in series with 5.1 k $\Omega$ ). This changes the value of the input and indicates to the MIM that the contact closure is active. If there is a short across + and -, if either leg is grounded, or if a break occurs on either leg, the MIM indicates that a fault has occurred.

**NOTE:** The terminating resistors are not included with the MIM. These resistors are included in a kit (12509-003) that must be ordered separately.

### Mode 4: IAC Line Supervision

(Reserved for 12579-003 Monitored Relay Module)

Mode 5: IDC Non-Supervision Multiple Switch (Dry Contact)

In this mode, any number of normally-open dry contact closures can be installed on the line. The loop will not be monitored for any faults in Mode 5.

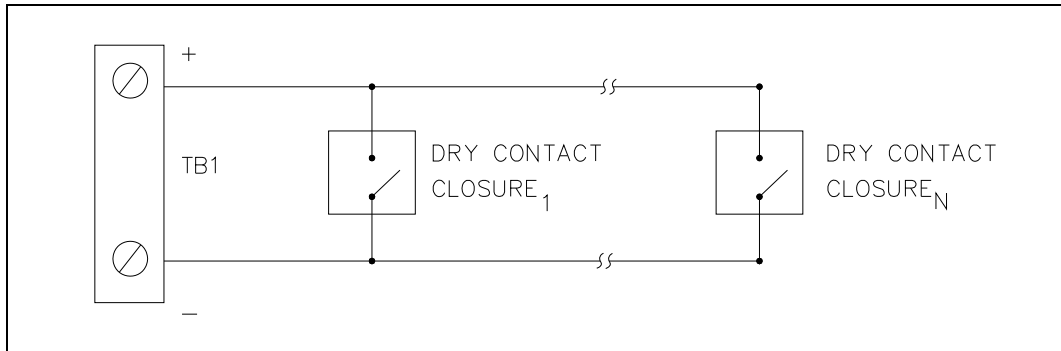

Figure 5. IDC Non-Supervision Multiple Switch (Dry Contact)

Mode 5: IDC Non-Supervision (Wet Contact)

In this wet contact mode, shorting jumpers for each input must be moved from the factory default of “dry” to “wet” contact mode. When in “wet” contact mode, the input can be activated during a 0 V condition or a 24 V condition. The factory default setting is “24 V dc input when active” (position 2-3).

If “0 V dc input when active” is desired, move jumper from position 2-3 to position 1-2. The loop will not be monitored for any faults in Mode 5. Ensure the polarity of input connection is correct as it is polarity sensitive.

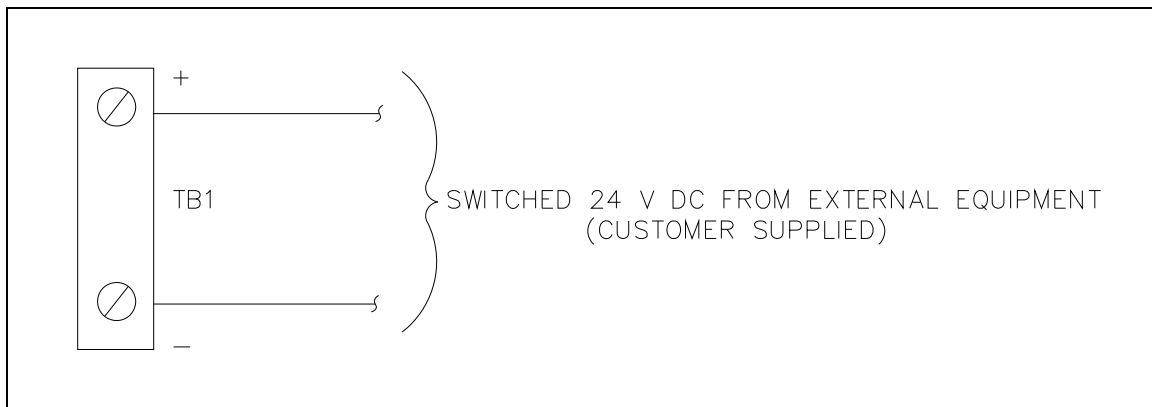

Figure 6. IDC Non-Supervision (Wet Contact)



**Table 1. Jumper Settings for Mode 5 Input Operation**

Input No.	Dry Contact Input Selection	24 V DC Wet Contact Input Selection	Factory Default Setting
1	P1 – Pins 2 & 3 P2 – Pins 2 & 3 P3 – Pins 2 & 3	P1 – Pins 1 & 2 P2 – Pins 1 & 2 0 V dc – Active: P3 – Pins 1 & 2 24 V dc – Active: P3 – Pins 2 & 3	P1 – Pins 2 & 3 P2 – Pins 2 & 3 P3 – Pins 2 & 3
2	P4 – Pins 2 & 3 P5 – Pins 2 & 3 P6 – Pins 2 & 3	P4 – Pins 1 & 2 P5 – Pins 1 & 2 0 V dc – Active: P6 – Pins 1 & 2 24 V dc – Active: P6 – Pins 2 & 3	P4 – Pins 2 & 3 P5 – Pins 2 & 3 P6 – Pins 2 & 3
3	P7 – Pins 2 & 3 P8 – Pins 2 & 3 P9 – Pins 2 & 3	P7 – Pins 1 & 2 P8 – Pins 1 & 2 0 V dc – Active: P9 – Pins 1 & 2 24 V dc – Active: P9 – Pins 2 & 3	P7 – Pins 2 & 3 P8 – Pins 2 & 3 P9 – Pins 2 & 3
4	P10 – Pins 2 & 3 P11 – Pins 2 & 3 P12 – Pins 2 & 3	P10 – Pins 1 & 2 P11 – Pins 1 & 2 0 V dc – Active: P12 – Pins 1 & 2 24 V dc – Active: P12 – Pins 2 & 3	P10 – Pins 2 & 3 P11 – Pins 2 & 3 P12 – Pins 2 & 3
5	P13 – Pins 2 & 3 P14 – Pins 2 & 3 P15 – Pins 2 & 3	P13 – Pins 1 & 2 P14 – Pins 1 & 2 0 V dc – Active: P15 – Pins 1 & 2 24 V dc – Active: P15 – Pins 2 & 3	P13 – Pins 2 & 3 P14 – Pins 2 & 3 P15 – Pins 2 & 3
6	P16 – Pins 2 & 3 P17 – Pins 2 & 3 P18 – Pins 2 & 3	P16 – Pins 1 & 2 P17 – Pins 1 & 2 0 V dc – Active: P18 – Pins 1 & 2 24 V dc – Active: P18 – Pins 2 & 3	P16 – Pins 2 & 3 P17 – Pins 2 & 3 P18 – Pins 2 & 3
7	P19 – Pins 2 & 3 P20 – Pins 2 & 3 P21 – Pins 2 & 3	P19 – Pins 1 & 2 P20 – Pins 1 & 2 0 V dc – Active: P21 – Pins 1 & 2 24 V dc – Active: P21 – Pins 2 & 3	P19 – Pins 2 & 3 P20 – Pins 2 & 3 P21 – Pins 2 & 3
8	P22 – Pins 2 & 3 P23 – Pins 2 & 3 P24 – Pins 2 & 3	P22 – Pins 1 & 2 P23 – Pins 1 & 2 0 V dc – Active: P22 – Pins 1 & 2 24 V dc – Active: P22 – Pins 2 & 3	P22 – Pins 2 & 3 P23 – Pins 2 & 3 P24 – Pins 2 & 3

## Operation

The operation of the Model 12578-003 MIM is controlled by the MCU configuration. See the MCU configuration details in the system manual for all operation information.

### How to Diagnose Assembly/Model Faults

Symptom	Action
MIM does not communicate with MCU	<ul style="list-style-type: none"> <li>• Verify power is applied to the MIM.</li> <li>• Verify page line is connected to the MIM.</li> <li>• Verify address of MIM agrees with the setup configuration.</li> <li>• Ensure CPU PCBA is correctly connected via J1.</li> <li>• Call for service of the MIM.</li> </ul>
MIM does not recognize dry inputs	<ul style="list-style-type: none"> <li>• Verify total loop resistance is less than 100 <math>\Omega</math>.</li> <li>• Verify power is applied to the MIM.</li> <li>• Verify page line is connected to the MIM.</li> <li>• Verify end of line resistor(s) properly installed on each input circuit.</li> <li>• Call for service of the MIM.</li> </ul>
MIM does not activate an alarm with 24 V dc applied to input terminal. (Wet contact mode ONLY.)	<ul style="list-style-type: none"> <li>• Verify that the jumper that selects the proper “_ V dc when active” mode is in the correct position for the desired mode. Refer to Mode 5 - IDC Non-Supervision (Wet Contact) information.</li> <li>• Verify that the applicable input jumpers have been repositioned for WET operation.</li> <li>• Verify that the input is within the acceptable dc voltage range (20–30 V dc)</li> <li>• Verify that the proper voltage polarity has been observed for external connections to the input terminals.</li> <li>• Call for service of the MIM.</li> </ul>

# Specifications

## Electrical

Power requirements .....	9–15 V dc (12 V dc nominal)
Current draw .....	300 mA maximum @ 12 V dc (no ground faults)
Number of input loops .....	Eight loops
Maximum devices on input loop.....	Unlimited (Mode 1) One (Mode 2) One (Mode 3) Unlimited (Mode 5 – Dry) One (Mode 5 – Wet)
Input/output.....	Power in Power out Page line (FSK) in Page line (FSK) out Eight field inputs
Data communications.....	FSK
End-of-line device.....	20 kΩ (Mode 1) 5.1 kΩ in series with 15 kΩ across contact (Mode 2) 5.1 kΩ in series with 15 kΩ across contact (Mode 3) None (Mode 5)

## Field Inputs

### Mode 1:

Contact closure resistance (activated).....	1 kΩ maximum
Open fault detection.....	Minimum 65 kΩ
Ground fault detection .....	Less than 200 Ω to ground

### Modes 2 and 3:

Contact closure resistance (Mode 2: activated/ Mode 3: de-activated) .....	3 kΩ maximum
Open fault detection.....	Minimum 65 kΩ
Ground fault detection .....	Less than 200 Ω to ground
Wire-to-wire short fault detection.....	Less than 200 Ω

### Mode 5 (Dry)

Contact closure resistance.....	900 Ω maximum
---------------------------------	---------------

### Mode 5 (Wet)

DC input voltage range .....	20–30 V dc (24 V dc nominal)
------------------------------	------------------------------

### Limitations:

Cable limitations .....	100 Ω maximum loop resistance
-------------------------	-------------------------------

### Terminals:

Minimum conductor size .....	No. 28 AWG (0.5 mm <sup>2</sup> )
Maximum conductor size.....	No. 12 AWG (3.0 mm <sup>2</sup> )

Mechanical

Unit dimensions ..... 4.00 H × 10.50 W × 1.25 D inches (101.60 × 266.70 × 31.75 mm)

Unit weight ..... 1.00 lb. maximum

Environmental

Temperature range (operating/storage)..... -30° C to 70° C (-22° F to 158° F)

Humidity ..... 95% non-condensing relative humidity

### Replacement Parts

Model No.	Description
69613-001	CPU PCBA
69251-201	Monitored In-8 PCBA

## Reference Material

### REFERENCE TO ASSEMBLY/MODEL DRAWINGS

Published By	Title	GAI-Tronics Ref. No.
GAI-Tronics	Monitored Input Module Assembly Drawing	73567

# Warranty

---

Equipment. GAI-Tronics warrants for a period of one (1) year from the date of shipment, that any GAI-Tronics equipment supplied hereunder shall be free of defects in material and workmanship, shall comply with the then-current product specifications and product literature, and if applicable, shall be fit for the purpose specified in the agreed-upon quotation or proposal document. If (a) Seller's goods prove to be defective in workmanship and/or material under normal and proper usage, or unfit for the purpose specified and agreed upon, and (b) Buyer's claim is made within the warranty period set forth above, Buyer may return such goods to GAI-Tronics' nearest depot repair facility, freight prepaid, at which time they will be repaired or replaced, at Seller's option, without charge to Buyer. Repair or replacement shall be Buyer's sole and exclusive remedy. The warranty period on any repaired or replacement equipment shall be the greater of the ninety (90) day repair warranty or one (1) year from the date the original equipment was shipped. In no event shall GAI-Tronics warranty obligations with respect to equipment exceed 100% of the total cost of the equipment supplied hereunder. Buyer may also be entitled to the manufacturer's warranty on any third-party goods supplied by GAI-Tronics hereunder. The applicability of any such third-party warranty will be determined by GAI-Tronics.

Services. Any services GAI-Tronics provides hereunder, whether directly or through subcontractors, shall be performed in accordance with the standard of care with which such services are normally provided in the industry. If the services fail to meet the applicable industry standard, GAI-Tronics will re-perform such services at no cost to buyer to correct said deficiency to Company's satisfaction provided any and all issues are identified prior to the demobilization of the Contractor's personnel from the work site. Re-performance of services shall be Buyer's sole and exclusive remedy, and in no event shall GAI-Tronics warranty obligations with respect to services exceed 100% of the total cost of the services provided hereunder.

Warranty Periods. Every claim by Buyer alleging a defect in the goods and/or services provided hereunder shall be deemed waived unless such claim is made in writing within the applicable warranty periods as set forth above. Provided, however, that if the defect complained of is latent and not discoverable within the above warranty periods, every claim arising on account of such latent defect shall be deemed waived unless it is made in writing within a reasonable time after such latent defect is or should have been discovered by Buyer.

Limitations / Exclusions. The warranties herein shall not apply to, and GAI-Tronics shall not be responsible for, any damage to the goods or failure of the services supplied hereunder, to the extent caused by Buyer's neglect, failure to follow operational and maintenance procedures provided with the equipment, or the use of technicians not specifically authorized by GAI-Tronics to maintain or service the equipment. **THE WARRANTIES AND REMEDIES CONTAINED HEREIN ARE IN LIEU OF AND EXCLUDE ALL OTHER WARRANTIES AND REMEDIES, WHETHER EXPRESS OR IMPLIED BY OPERATION OF LAW OR OTHERWISE, INCLUDING ANY WARRANTIES OF MERCHANTABILITY OR FITNESS FOR A PARTICULAR PURPOSE.**

## Return Policy

---

If the equipment requires service, contact your Regional Service Center for a return authorization number (RA#). Equipment should be shipped prepaid to GAI-Tronics with a return authorization number and a purchase order number. If the equipment is under warranty, repairs or a replacement will be made in accordance with the warranty policy set forth above. Please include a written explanation of all defects to assist our technicians in their troubleshooting efforts.

Call 800-492-1212 (inside the USA) or 610-777-1374 (outside the USA) for help identifying the Regional Service Center closest to you.