



GAI-TRONICS®
A HUBBELL COMPANY

Model 12576-501(x) Rack-Mount Access Panel with LCD Display

TABLE OF CONTENTS

Confidentiality Notice 1

General Information 1

Product Overview 1

Features..... 1

Options..... 2

Installation 2

Important Safety Instructions..... 2

Mounting..... 2

Field Wiring..... 3

 TX/RX Data 4

 Power 4

 Audio In 4

 Remote Speaker 4

 LED Driver Outputs..... 4

 Contact Closure Inputs..... 5

Configuration 6

User Adjustments..... 6

 Front Panel Speaker Volume Adjustment..... 6

 Sonalert Volume Adjustment..... 6

Internal Adjustments..... 6

 Open the Enclosure 6

 Jumper Configuration 8

 Potentiometer Adjustments 8

 Front Panel Installation 9

Keypad Labels..... 9

 Label Installation 9

 Label Removal..... 9

Operation 10

Push-Button Switch Summary..... 10

Page Confirmation Tone 10

Page and Party Line Operation (typical)..... 10

Timeout Features 11

Handset Paging Pre-announcement Tones 11

Alarm Activation	11
Sonalert	11
Lamp Test Feature	12
<i>Options</i>	<i>12</i>
Push-Button Switch Protective Cover	12
Key Lock Switch	13
<i>Maintenance</i>	<i>14</i>
Troubleshooting	14
Servicing Guidelines	14
Spare Parts	14
<i>Specifications</i>	<i>15</i>
Power Requirements	15
Access Panel Cabling	15
Handset	15
Handset Amplifier	15
External Audio Input	15
Front Panel Speaker Amplifier	15
Remote Speaker Amplifier	15
LED Outputs	16
Input Contacts	16
Mechanical	16
Environmental	16



GAI-TRONICS®
A HUBBELL COMPANY

Model 12576-501(x) Rack-Mount Access Panel with LCD Display

Confidentiality Notice

This manual is provided solely as an installation, operation, and maintenance guide and contains sensitive business and technical information that is confidential and proprietary to GAI-Tronics. GAI-Tronics retains all intellectual property and other rights in or to the information contained herein, and such information may only be used in connection with the operation of your GAI-Tronics product or system. This manual may not be disclosed in any form, in whole or in part, directly or indirectly, to any third party.

General Information

Product Overview

The Model 12576-501(x) Access Panel is a component of GAI-Tronics' ADVANCE System. The operation of each access panel is programmed at the ADVANCE System Control Cabinet. Operating capabilities include: voice paging, party line communication (with other access panels or Page/Party® stations), activation/reset of emergency alarms, and a text display of the system operating status.

The access panel speaker(s) can broadcast page and alarm audio. A sounder (sonalert) can annunciate system alarm/trouble conditions or communication requests to the access panel operator.

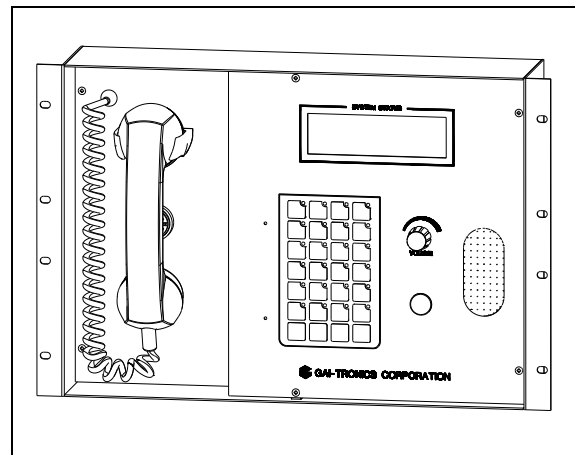

Figure 1. Model 12576-501

Features

- 120/230 V ac, 50/60 Hz input power
- standard 19-inch EIA rack-mountable
- handset with pressbar paging switch
- LCD text display
- five external switch inputs
- 24 LED switch indicators (software-configurable)
- 24 external LED driver outputs
- front panel speaker with volume control
- external speaker connection
- sonalert with volume control
- lamp test push button
- external audio input
- 28 push-button switches (software-configurable)

NOTE: It is necessary to make changes to the ADVANCE configuration file before using this unit as a replacement for a previous rack-mount access panel. Please contact GAI-Tronics Service for details.

Options

- protective door cover for push buttons
- key lock switch to disable push buttons

Installation

Important Safety Instructions

- **Read, follow, and retain instructions**—All safety and operating instructions should be read and followed before operating the unit. Retain instructions for future reference.
- **Heed warnings**—Adhere to all warnings on the unit and in the operating instructions.
- **Attachments**—Attachments not recommended by the product manufacturer should not be used, as they may cause hazards.
- **Servicing**—Do not attempt to service this unit by yourself. Opening or removing covers may expose you to dangerous voltage or other hazards. Refer all servicing to qualified service personnel.

This permanently connected apparatus must have a UL Listed 15-amp circuit breaker incorporated in the electrical installation of the building.

USA and Canada—Consult the National Electrical Code (NFPA 70), Canadian Standards Association (CSA 22.1), and local codes for specific requirements regarding your installation. Class 2 circuit wiring must be performed in accordance with NEC 725.55.

Mounting

NOTE: Mounting hardware is not included with this assembly and must be purchased separately.

1. Remove the access panel from its protective packing.
2. Position the access panel in the 19-inch EIA enclosure.
3. Secure the access panel with the appropriate screws.

When installed correctly, the handset will be on the left side of the access panel (see [Figure 2](#)).

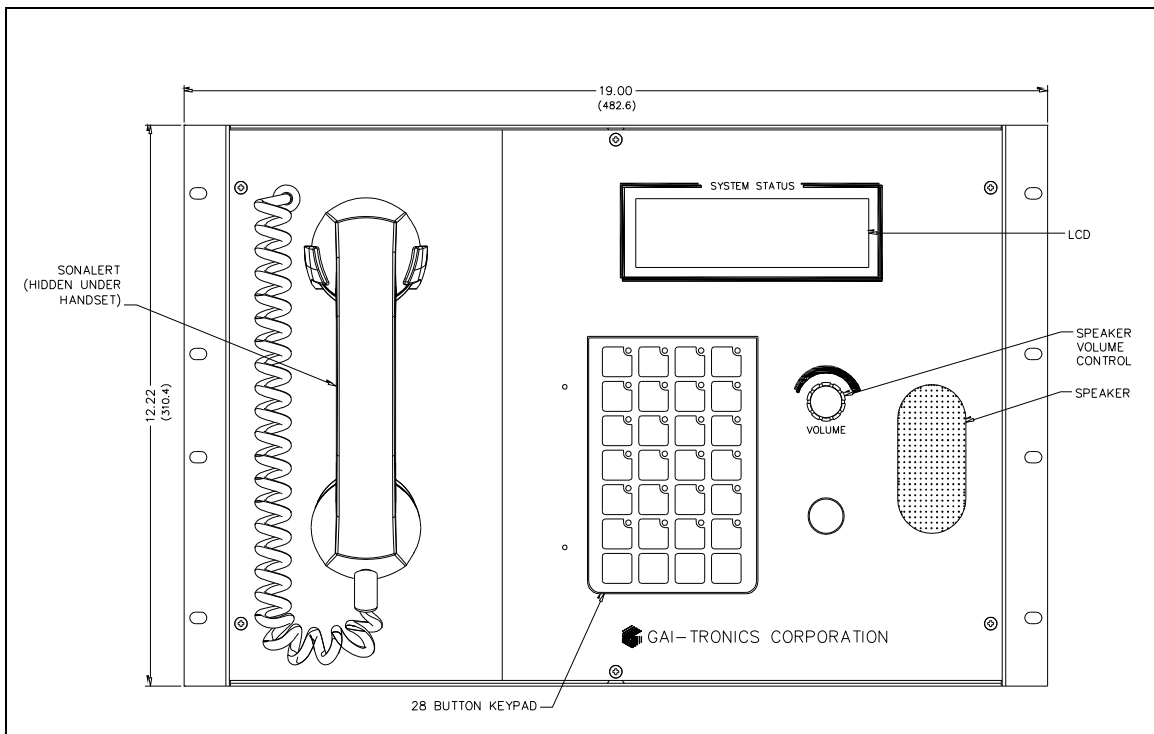

Figure 2. Access Panel—Front View

Field Wiring

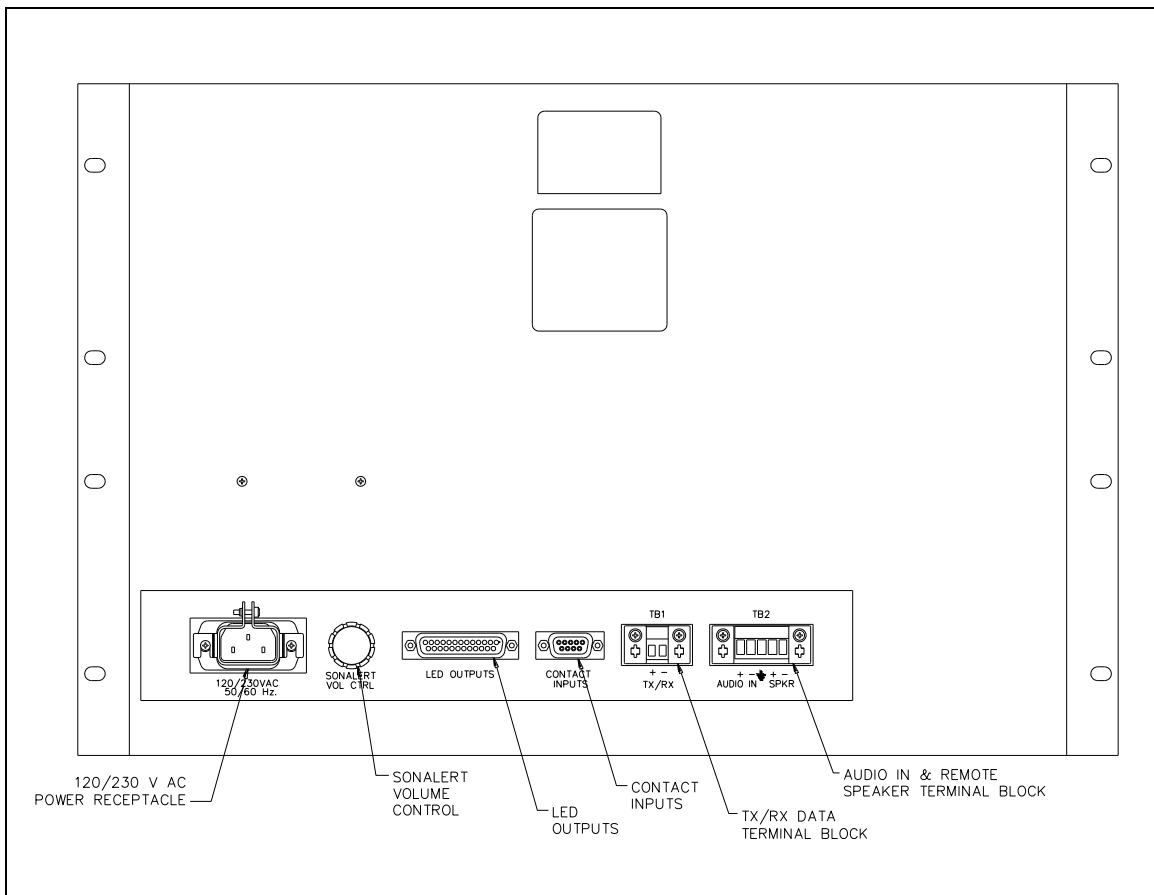

Figure 3. Access Panel—Rear View

TX/RX Data

Connect the access panel data line from the ADVANCE system control cabinet to terminal block TB1 on the rear panel (see [Figure 3](#)).

- Use a minimum Category 3 twisted pair cable for this connection.
- Observe cable conductor polarity (+/-) at the control cabinet: (+ connects to + and - connects to -). No damage will occur if the polarity is reversed, but the access panel will not function.
- Maximum cable distance to the control cabinet is 3 km when using No. 24 AWG (Category 3) cable.

Power

The access panel is supplied with a modular power cord that plugs into the rear panel (see [Figure 3](#)).

1. Loosen the power connector lock on the rear of the access panel.
2. Plug the power cord into the connector and retighten the power connector lock.
3. Plug the other end into a grounded ac electrical outlet (120/230 V ac).

NOTE: The access panel does not have an on/off power switch and will power up immediately upon plugging in the power cable. The ADVANCE System control cabinet must also be powered and running before the access panel is operational. LEDs on the access panel will flash and the display will read “No communication with ADVANCE” until data communication is established with the ADVANCE control cabinet.

Audio In

Connect an external audio source to terminal block TB2 on the rear panel (see [Figure 3](#)).

- Connect the audio source using No. 18–24 AWG shielded twisted pair cable.
- The audio is summed with the handset microphone and can be broadcast to the system party line when the hookswitch is activated.
- For broadcast to the system paging speakers, the hookswitch and page switch must both be activated.

Remote Speaker

Connect an external speaker to terminal block TB2 on the rear panel (see [Figure 3](#)).

- Connect the speaker using a No. 18–22 AWG twisted pair cable.
- The speaker will broadcast the same audio as the front panel speaker but will not be affected by the front panel volume control.

LED Driver Outputs

The DB-25 connector on the rear panel provides 24 LED driver outputs for powering external indicators, mechanical relays, etc.

- The drivers are in parallel with the front panel LED indicators on the keypad switch. When the front panel LED is on, the corresponding output pin is on.
- The pin out of the connector correlates to the LED number, e.g. pin 1 is for LED 1, pin 2 is LED 2, etc. Pin 25 is +5 V dc to power the remote indicators or relays (see [Figure 4](#) and [Figure 5](#)).

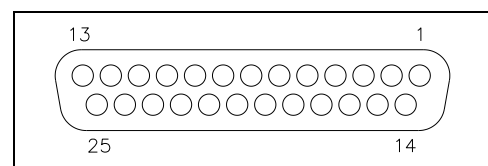

Figure 4. DB-25 Pin Out

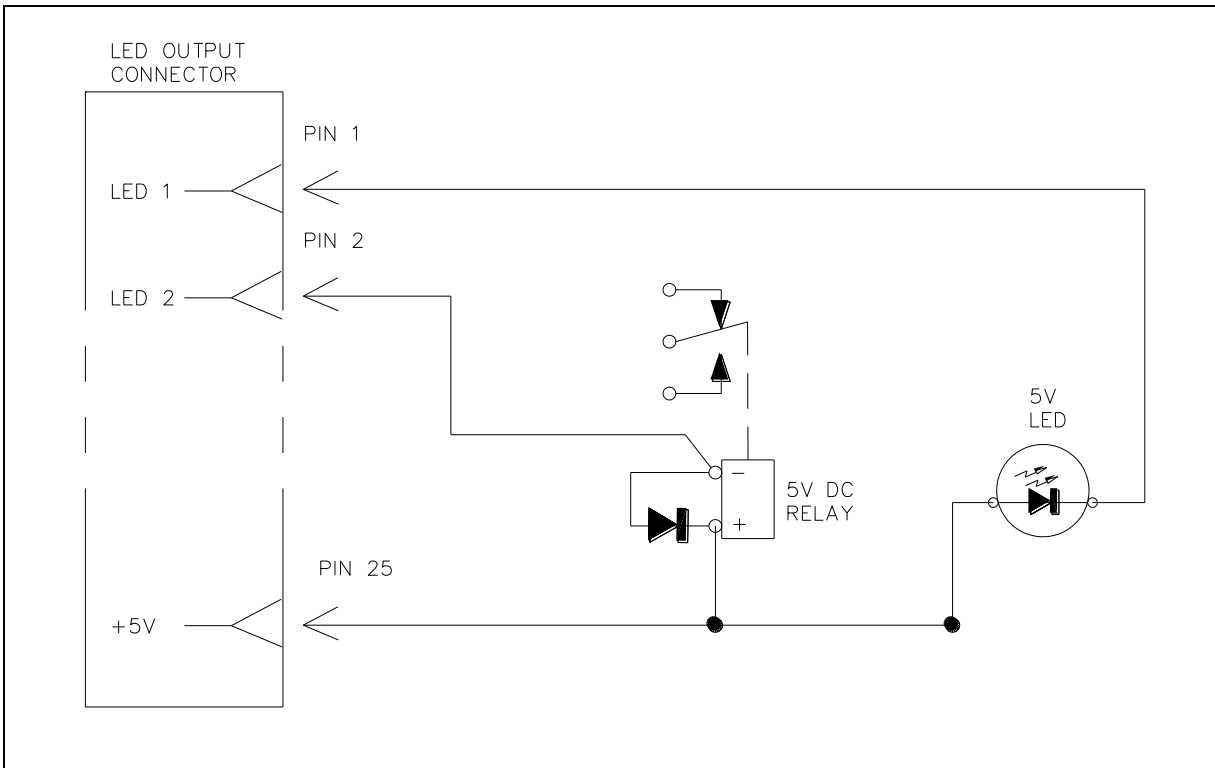

Figure 5. Typical Connection Diagram

Contact Closure Inputs

The DB-9 connector on the rear panel allows connection of external switches for access to the page switch, hookswitch, and three programmable inputs.

- The page and hookswitch inputs are wired in parallel to the page switch contacts (on the handset) and hookswitch contacts (in the handset cradle).
- Inputs 1–3 are wired in parallel to push buttons 26, 27, and 28 on the front panel.

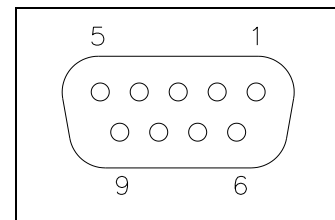

Figure 6. DB-9 Pinout

Table 1. Contact Closure Input Connector—Pin Out

DB-9 Pin Number	Function
1	Input contact 1
2	Input contact 2
3	Input contact 3
4	Page switch
5	Hookswitch
6	GND
7	GND
8	GND
9	GND

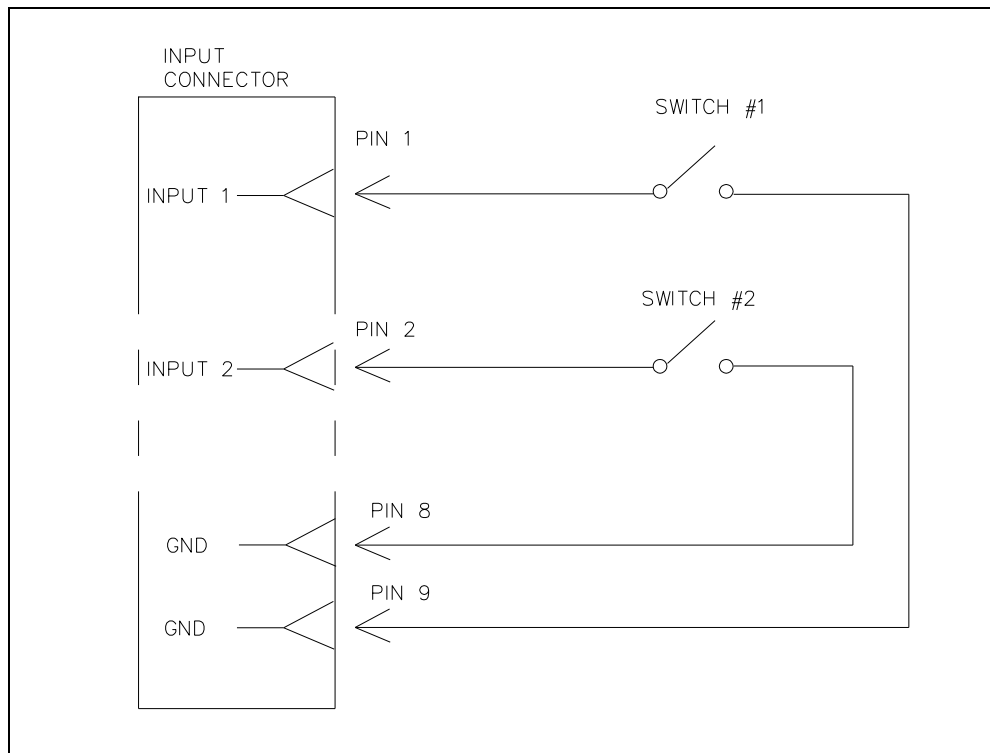

Figure 7. Typical Connection Diagram

Configuration

User Adjustments

Front Panel Speaker Volume Adjustment

Use the volume control on the front panel to adjust the volume of the front panel speaker. This volume control does not affect any remote speakers connected to the access panel. Remote speaker volume control requires the use of a GAI-Tronics Model 12506-001 Remote Volume Control (or equal).

Sonalert Volume Adjustment

Use the volume control on the rear panel to adjust the volume level of the sonalert alarm. Clockwise rotation increases the volume and counterclockwise rotation decreases the volume.

Internal Adjustments

Open the Enclosure

1. Remove the six screws from the front panel.
2. Open the access panel by rotating the front panel to the left as if on a hinge near the handset.
3. Do not disconnect any cables.

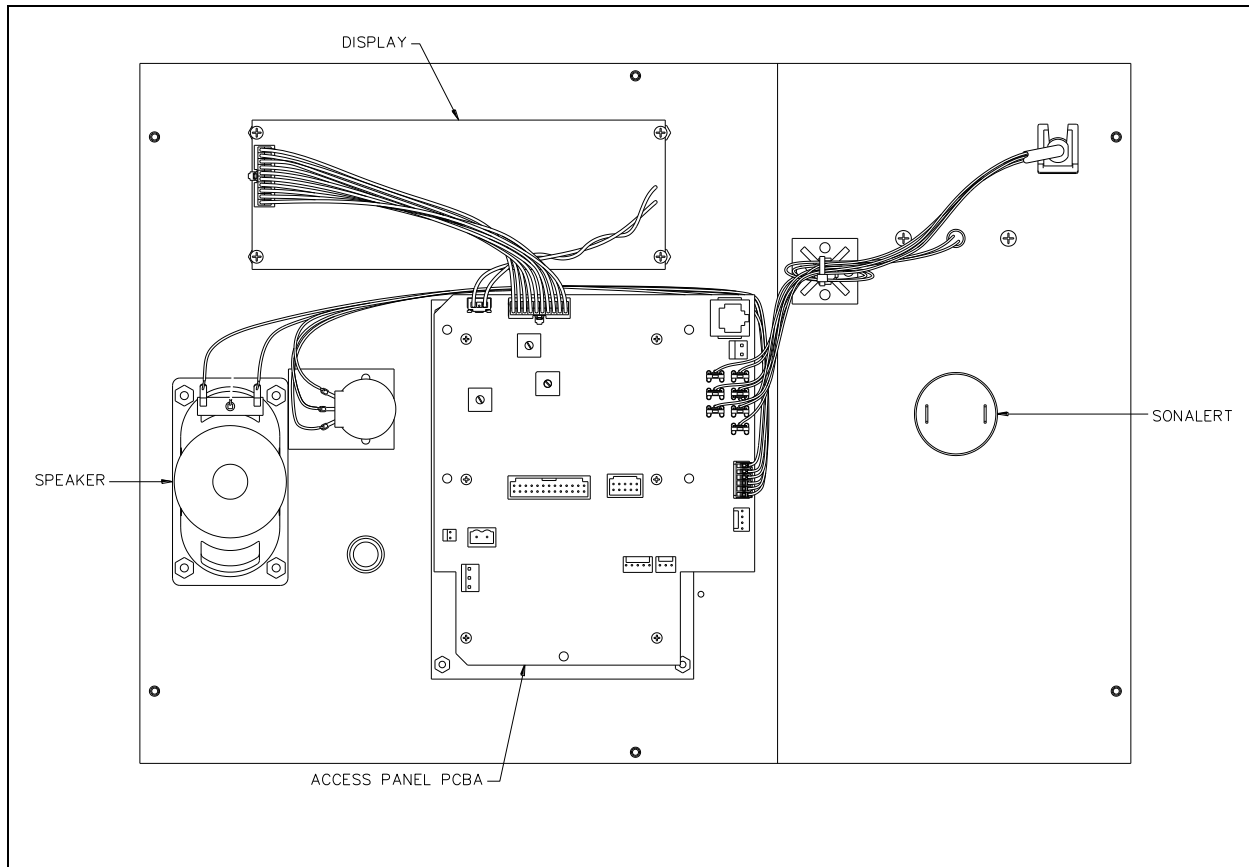

Figure 8. Rear View of Front Panel Assembly

Jumper Configuration

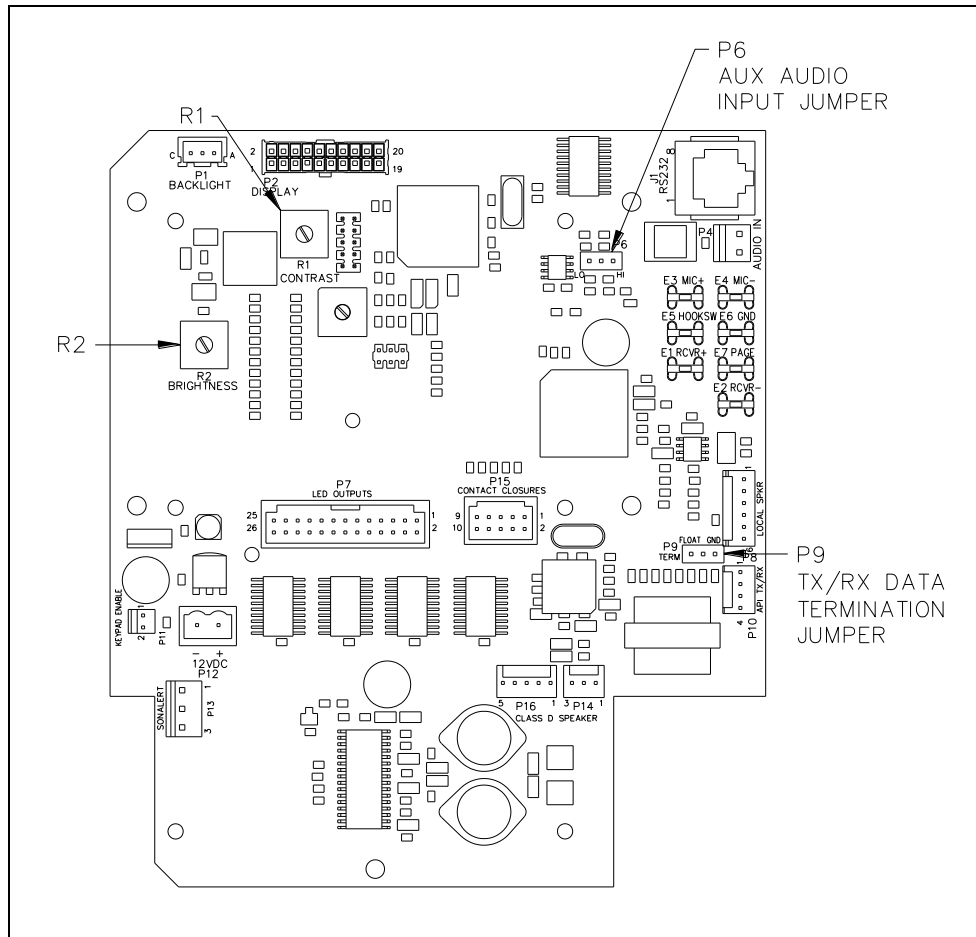

Figure 9. Access Panel PCBA

External Audio Input

Jumper P6 must be set to match the input level (line or microphone) of the external audio source connected to the access panel at TB2 (see [Figure 9](#)).

- Place P6 in the HI position (default setting) for a line level audio signal.
- Place P6 in the LO position for microphone level audio signals.

TX/RX Data

Jumper P9 provides a ground reference to the access panel data line (see [Figure 9](#)). A similar jumper is located on the API (Access Panel Interface) card in the system control cabinet.

NOTE: The data line must be ground referenced on only one side of the communication link.

- Place P9 in the GND position to create a ground reference.
- Place P9 in the FLOAT position (default) to remove the ground reference.

Potentiometer Adjustments

LCD Display Brightness

Potentiometer R2 adjusts the brightness of the backlight of the display (see [Figure 9](#)). Clockwise rotation increases the brightness and counterclockwise rotation decreases the brightness.

LCD Display Contrast

Potentiometer R1 adjusts the contrast of the display (see [Figure 9](#)). Clockwise rotation increases the contrast and counterclockwise rotation decreases the contrast.

Front Panel Installation

After all adjustments have been completed:

1. Place the front panel on the rear enclosure
Do not pinch any cables.
2. Secure the front cover using the six screws previously removed.

Keypad Labels

The keypad on the front panel uses *slide-in* labels to identify the individual switch functions. Two sheets of blank labels are included with the access panel (GAI-Tronics Part No. 14919-113).

The labels are printed by inserting the blank sheets into any laser or inkjet printer. A Microsoft® Word document (Version 97) is available to create custom labels. It is available for download at www.gai-tronics.com.

1. Hover the mouse pointer over the **RESOURCES** tab at the top of the page.
2. Click the **MANUALS** link under **USEFUL LINKS**.
3. Click the **IOMS/USER GUIDES** link on the **MANUALS** page.
4. Scroll down to document 42004-728L2E
5. Click the [Access Panel Label Template](#) link.

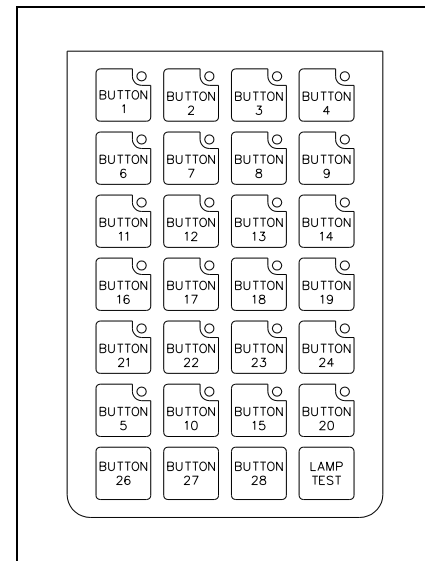

Figure 10. Keypad Button Layout

NOTES:

- To modify the text size and color of the text in the blocks, you must *unprotect* the document. Do not re-protect the document; otherwise, all the information that was typed in will be lost.
- Before printing on the included slide-in labels, print a test page on plain paper to verify that the positioning, orientation, and information are correct. Check the printed paper by laying it behind the included slide-in label sheet to verify that the print is in the proper location. Because printers vary, you may need to adjust the margins in the page setup to center the printed text within the perforated strips.

Label Installation

1. Separate the slide-in labels along the perforated lines on the sheet.
2. Fold the tab at the end of the slide-in label so that it is perpendicular to the rest of the label.
3. Slide the label into the appropriate slot opening located at the top of each of the button columns.
4. Repeat the above steps for the remaining labels.

Label Removal

1. Locate the tab at the top of the label and pull it out from behind.
2. Slide the label out using the tab that has been exposed.

Operation

The Model 12576-501(x) Access Panel provides voice communication, system control functions, and system operating status on the LCD display. The following paragraphs provide a general overview of the available access panel features. Operational details for each access panel are determined by software programming at the ADVANCE System control cabinet.

The access panel handset is used for paging and party line communication. Push-button switches are used for a variety of system control functions.

Push-Button Switch Summary

Each push-button switch function and LED indicator (next to the switch) is programmable. Typical switch functions include alarm activation/reset, paging zone selection, or beacon activation/reset. Other special functions are available through system programming.

Page Confirmation Tone

When paging from an access panel, a short *page-confirmation* tone will be heard in the handset receiver when the page switch is depressed.

- Do not talk until the tone ceases.
- The page request has been granted by the system control cabinet when the tone ceases.
- The page request has been rejected if a busy tone is heard.

Page rejection occurs when a higher priority page or alarm is in progress at the time of the page request.

Page and Party Line Operation (typical)

Complete the following steps to make a page announcement from an access panel:

1. Lift the handset from the cradle.
2. Select the desired paging destination(s) or all call. The LEDs of the selected switches illuminate.
3. Press and hold the handset pressbar switch.
4. After the *page-confirmation* tone is heard, speak directly into the microphone to broadcast the announcement.
5. Release the handset pressbar when complete.
6. Upon releasing the pressbar switch, the access panel handset is connected to party line one or two.
7. Return the handset to the cradle following a page or a party line conversation.

NOTE: To cancel any selected destination push-button switch, press the switch again and the LED will extinguish. The access panel automatically deselects the paging destination(s) after a page is completed.

Complete the following steps to respond to a page:

1. Pick up a station's handset.
2. Turn the selector switch to party line one or two.

Party line communication is not broadcast over the system speakers. Other individuals can also pick up a handset and join the conversation at any time.

3. Return the handset to the cradle following a page or a party line conversation.

Timeout Features

Each access panel can be programmed to limit handset paging time and the amount of time the handset can be in use or off-hook. These features are often used to identify handsets that have accidentally been left off-hook or to restrict an access panel from being in use for prolonged periods of time.

Page Timeout—sets amount of time that the access panel can generate a page. If the limit is exceeded, the page will cease and a busy tone is heard in the handset receiver. A trouble report will be sent to the control cabinet. If the handset page switch is released, the page timer is reset. The page timeout can be disabled or set for 1–25 minutes in 1-minute intervals.

NOTE: By default, the page time-out for access panels is disabled.

Off-Hook Timeout—sets amount of time that the access panel can be in use or off-hook. If the limit is exceeded, handset operation will cease and the access panel will be placed electrically on-hook. A trouble report is sent to the control cabinet. The handset remains inoperative until it is physically placed back on-hook. The off-hook timeout can be disabled or set from 1–25 minutes in 1-minute intervals.

NOTE: By default the off-hook time-out for access panels is disabled.

Handset Paging Pre-announcement Tones

An access panel page can be preceded by one of two available tones. Tone selection is based on the system mode of operation at the time of the page (normal or alarm). The *Splash* is a Hi-Lo tone approximately 1 second in duration. The *Alert* is a swept tone approximately 1 second in duration.

NOTE: By default, the preannouncement tone is disabled.

Alarm Activation

Activate an alarm from the access panel as follows:

1. Select the desired destination using the zone push button(s) if configured. The destination can be a single zone, a group of zones, or all zones. The LEDs of the selected zone switches illuminate.
2. Select the appropriate alarm push button. The alarm broadcasts into the selected zones, and the LED of the selected alarm illuminates during the broadcast.
3. *For access panels equipped with an ENTER push button:* Press the ENTER push button after pressing the alarm push button to activate the alarm in the selected zones.

NOTES:

- Press the CANCEL CURRENT or the RESET ALL push button to cancel any concurrent alarm. This cancels all alarms that are currently playing or that are in the alarm queue.
- Alarms may also be configured to play immediately when the alarm push button is pressed. In this case a zone selection is not required. The alarm's destination is pre-configured in the system programming.

Sonalert

The sonalert is an audible indicator and its control signal is paralleled with LED output #20. It is typically configured to sound when a new message is available on the LCD.

- Press the ACK/NEXT push button to display each new message, if configured as described above.
- The sonalert turns off once the last available new message has been displayed.

Lamp Test Feature

The lamp test feature is used to verify that the access panel indicators are functioning properly. When the LAMP TEST push button is pressed, the switch indicators illuminate, and the panel sonalert will sound.

NOTE: The LAMP TEST and PREVIOUS push buttons do not include an indicator.

Options

Two options are available on the access panel:

Push-Button Switch Protective Cover

The push-button switch protective cover consists of a clear cover with a hinge and magnetic latch (see [Figure 11](#)). The door must be opened to access the keypad switches preventing accidental push-button activation.

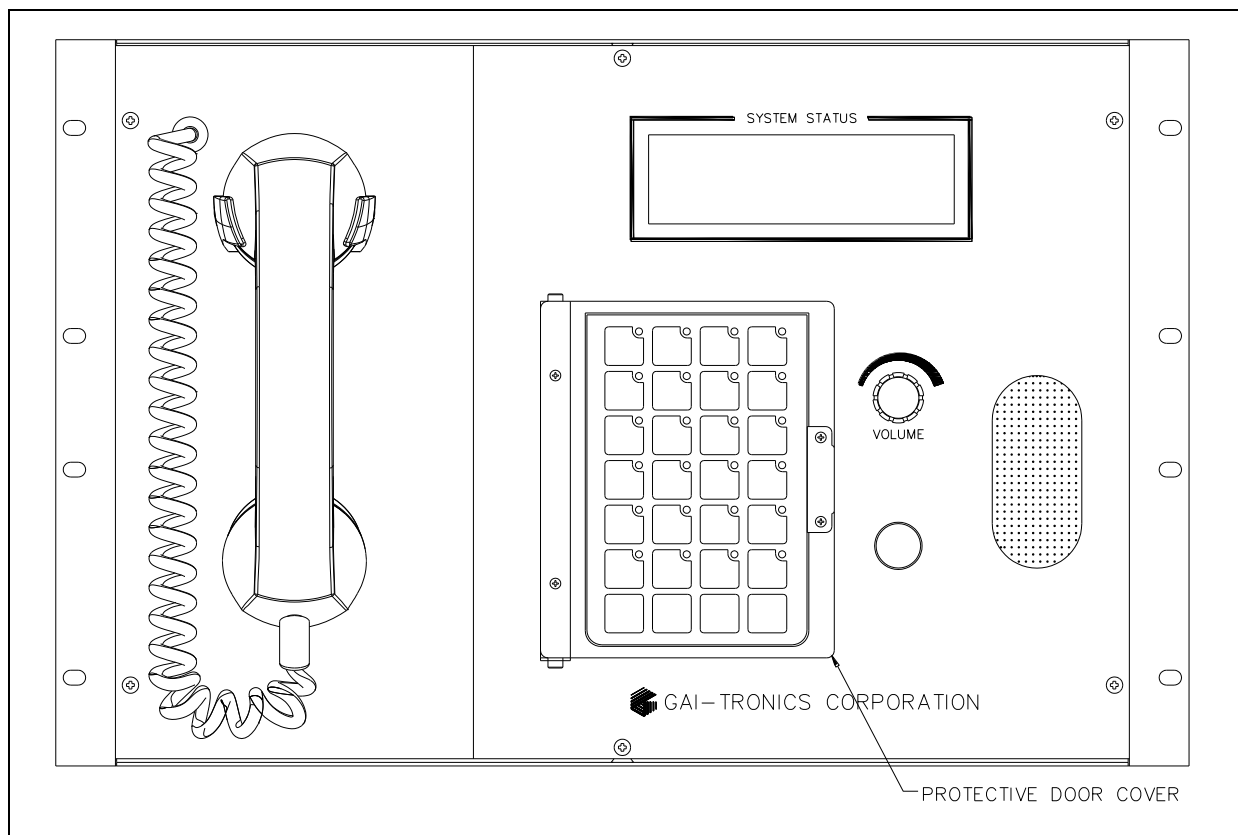

Figure 11. No. 12576-501D Rack-Mount Access Panel with Door Option

Key Lock Switch

The key lock switch prevents unauthorized use of the push-button switches (see [Figure 12](#)). The push-button switches are disabled until the key is inserted and switched to the *Enable* position. The key cannot be removed when in the *Enable* position.

NOTE: The handset, speaker, and display functions are not affected by the key lock switch.

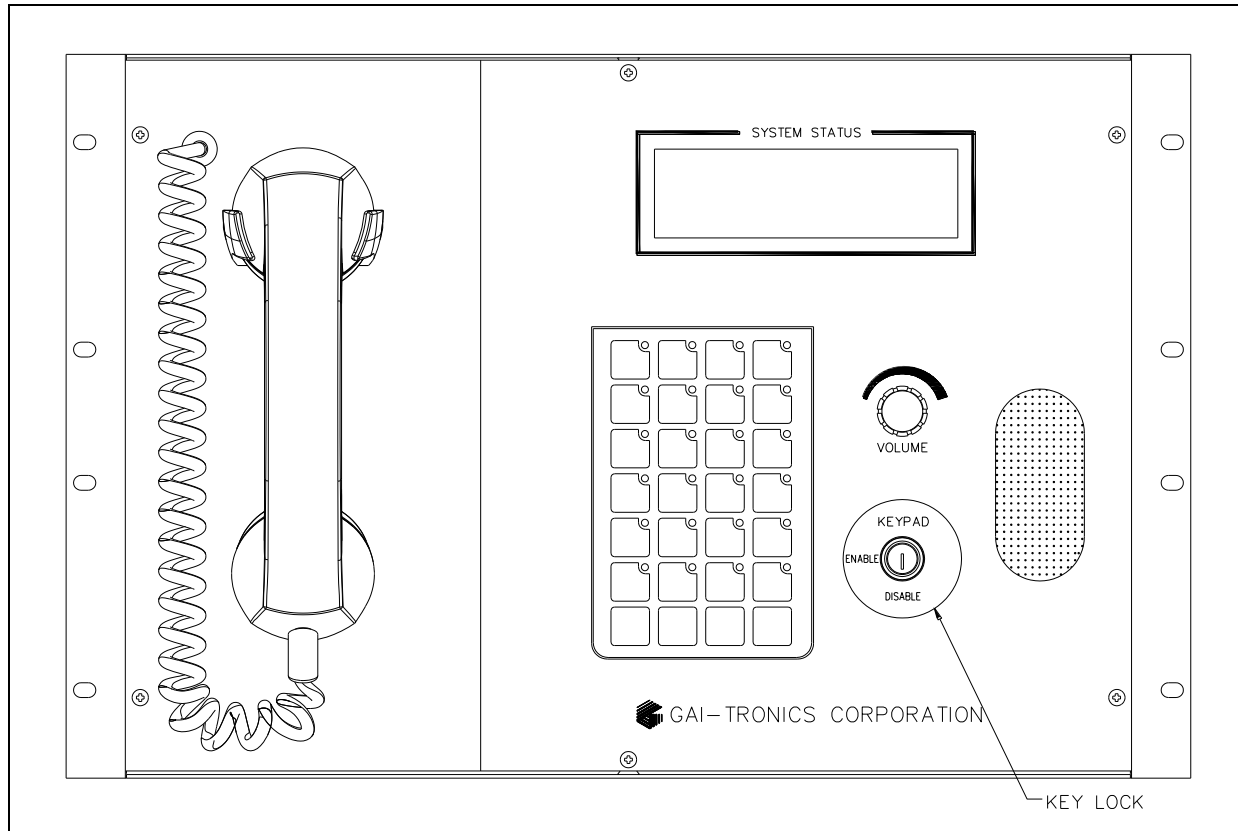

Figure 12. No. 12576-501K Rack-Mount Access Panel with Key Lock Option

Maintenance

Troubleshooting

Symptom	Possible Cause
Access panel LEDs flash and sonalert is sounding. The panel is not operational.	<p>The access panel has lost data communication with the API (Access Panel Interface) card in the ADVANCE System Control Cabinet.</p> <p>Possible Causes:</p> <ul style="list-style-type: none"> • disconnected data cable between the API card and access panel • data cable connected to an un-programmed API card output • data cable polarity is reversed (observe +/- polarity) • defective API card • defective access panel PCBA
Access panel speaker does not broadcast.	<ul style="list-style-type: none"> • speaker volume control is turned down • defective speaker • defective handset hookswitch <p>The speaker is muted when the handset is off-hook.</p>
Handset does not function but push-button switches do.	<ul style="list-style-type: none"> • defective hookswitch • hookswitch polarity programmed backwards
Handset does not page.	<ul style="list-style-type: none"> • access panel's paging destination not programmed • defective page switch or bad page switch wire connection at the PCBA inside the access panel
Some or all push-button switches do not function.	<ul style="list-style-type: none"> • push buttons not programmed • keypad is disabled (key switch input) • defective keypad
Handset receiver volume or microphone volume is low.	<ul style="list-style-type: none"> • handset levels (mic, receiver & side tone) set too low in the system programming • defective handset microphone or receiver
Display does not function	<ul style="list-style-type: none"> • display is not enabled in the system programming • display cable not connected at the PCBA inside the access panel

Servicing Guidelines

1. Notify plant personnel of a system shutdown prior to servicing the unit.
2. Disconnect power before connecting external wiring or installing or removing the access panel.

Spare Parts

Model No.	Description
14919-113	Keypad Replacement Slide-In Labels (Set of 4)

Specifications

Power Requirements

AC Power Supply:

Input voltage	120/230 V ac (nominal), 50/60 Hz
Maximum current draw @ nominal 120 V ac	200 mA
Maximum current draw @ nominal 230 V ac	135 mA

Access Panel Cabling

Twisted pair cable	Category 3 minimum
Nominal cable characteristic impedance.....	100 Ω
Frequency response.....	32.0 to 256 kHz
Maximum attenuation	24 dB
Signal level.....	1.000 to 1.125 V _{P-P}
Signal-to-noise level	>16.5 dB, 300 kHz bandwidth
Line length	3.0 km with Category 3, No. 24 AWG; attenuation = 8.0 dB/km

Handset

Microphone	dynamic, noise cancelling
Receiver	dynamic, hearing aid compatible
Cord	Hytrell, 6 ft
Material	black ABS
External Controls	push-to-page handset pressbar magnetic hookswitch

Handset Amplifier

Output level (through digital system connection).....	1.5 V _{RMS} into Page/Party [®] system
Frequency response.....	250–6500 Hz, +0/–3 dB ref to 1 kHz
Distortion	<1.5% THD @ 1 kHz
Receiver level (with 1.5 V _{RMS} on Page/Party [®] system).....	250 mV _{RMS}

External Audio Input

Low signal input for 1.5 V _{RMS} on Page/Party [®] system	3 mV _{RMS}
High signal input for 1.5 V _{RMS} on Page/Party [®] system.....	0.775 V _{RMS} (0 dBm)

Front Panel Speaker Amplifier

Output level (with 1.5 V _{RMS} on Page/Party [®] system).....	0.3 W
Frequency response.....	250–6500 Hz, +0/–3 dB ref to 1 kHz
Distortion	<1.5% THD @ 1 kHz to 0.2 W <5% THD @ 1 kHz to 0.3 W

Remote Speaker Amplifier

Output level (with 1.5 V _{RMS} on Page/Party [®] system).....	4 W
Frequency response.....	250–6500 Hz, +0/–3 dB ref to 1 kHz
Distortion	<1% THD @ 1 kHz

LED Outputs

Maximum current draw..... 35 mA per output
500 mA total
Maximum voltage applied to output 12 V dc through 1 kΩ load
Maximum current from 5-volt output (pin 25) 500 mA

Input Contacts

Contact closure resistance 1 kΩ maximum

Mechanical

Unit dimensions 19.00 H × 12.22 W × 4.11 D in (482.6 × 310.4 × 104.5 mm)
Net weight..... 14.5 lb (6.58 kg)
Shipping weight 16 lb (7.26 kg)

Environmental

Operating temperature range.....+32 °F to +120 °F (0 °C to +49 °C)
Relative humidity non-condensing 85% maximum

Warranty

Equipment. GAI-Tronics warrants for a period of one (1) year from the date of shipment, that any GAI-Tronics equipment supplied hereunder shall be free of defects in material and workmanship, shall comply with the then-current product specifications and product literature, and if applicable, shall be fit for the purpose specified in the agreed-upon quotation or proposal document. If (a) Seller's goods prove to be defective in workmanship and/or material under normal and proper usage, or unfit for the purpose specified and agreed upon, and (b) Buyer's claim is made within the warranty period set forth above, Buyer may return such goods to GAI-Tronics' nearest depot repair facility, freight prepaid, at which time they will be repaired or replaced, at Seller's option, without charge to Buyer. Repair or replacement shall be Buyer's sole and exclusive remedy. The warranty period on any repaired or replacement equipment shall be the greater of the ninety (90) day repair warranty or one (1) year from the date the original equipment was shipped. In no event shall GAI-Tronics warranty obligations with respect to equipment exceed 100% of the total cost of the equipment supplied hereunder. Buyer may also be entitled to the manufacturer's warranty on any third-party goods supplied by GAI-Tronics hereunder. The applicability of any such third-party warranty will be determined by GAI-Tronics.

Services. Any services GAI-Tronics provides hereunder, whether directly or through subcontractors, shall be performed in accordance with the standard of care with which such services are normally provided in the industry. If the services fail to meet the applicable industry standard, GAI-Tronics will re-perform such services at no cost to buyer to correct said deficiency to Company's satisfaction provided any and all issues are identified prior to the demobilization of the Contractor's personnel from the work site. Re-performance of services shall be Buyer's sole and exclusive remedy, and in no event shall GAI-Tronics warranty obligations with respect to services exceed 100% of the total cost of the services provided hereunder.

Warranty Periods. Every claim by Buyer alleging a defect in the goods and/or services provided hereunder shall be deemed waived unless such claim is made in writing within the applicable warranty periods as set forth above. Provided, however, that if the defect complained of is latent and not discoverable within the above warranty periods, every claim arising on account of such latent defect shall be deemed waived unless it is made in writing within a reasonable time after such latent defect is or should have been discovered by Buyer.

Limitations / Exclusions. The warranties herein shall not apply to, and GAI-Tronics shall not be responsible for, any damage to the goods or failure of the services supplied hereunder, to the extent caused by Buyer's neglect, failure to follow operational and maintenance procedures provided with the equipment, or the use of technicians not specifically authorized by GAI-Tronics to maintain or service the equipment. **THE WARRANTIES AND REMEDIES CONTAINED HEREIN ARE IN LIEU OF AND EXCLUDE ALL OTHER WARRANTIES AND REMEDIES, WHETHER EXPRESS OR IMPLIED BY OPERATION OF LAW OR OTHERWISE, INCLUDING ANY WARRANTIES OF MERCHANTABILITY OR FITNESS FOR A PARTICULAR PURPOSE.**

Return Policy

If the equipment requires service, contact your Regional Service Center for a return authorization number (RA#). Equipment should be shipped prepaid to GAI-Tronics with a return authorization number and a purchase order number. If the equipment is under warranty, repairs or a replacement will be made in accordance with the warranty policy set forth above. Please include a written explanation of all defects to assist our technicians in their troubleshooting efforts.

Call 800-492-1212 (inside the USA) or 610-777-1374 (outside the USA) for help identifying the Regional Service Center closest to you.