



GAI-TRONICS®
A HUBBELL COMPANY

SP2 Fiber Weatherproof Class I Div. 2 Handset/Speaker Amplifier Station

TABLE OF CONTENTS

<i>Confidentiality Notice</i>	1
<i>General Information</i>	1
Product Overview	1
Features	2
Options	2
<i>Installation</i>	3
Important Safety Instructions	3
Enclosure Mounting and Cable Entries	4
Open the Station	5
Field Wiring and Configuration	5
Station Ground	5
Termination PCBA Connections	6
Main PCBA—600-Ohm Audio I/O with Control	10
Fiber Termination PCBA	11
<i>Settings and Adjustments</i>	12
Open the Station	12
Main PCBA Configuration	13
Write Protect (EEPROM) Jumper.....	13
WDOG Enable (Watchdog) Jumper	13
Boot Enable Jumper	13
Reset Switch.....	13
Speaker and 600-ohm Audio Output Volume.....	14
Receiver Volume	14
Group and Station Number Selector Switches.....	15
Main PCBA Indicators	15
Power LED.....	15
Heartbeat LED	15
Ethernet Connection LEDs	15
Five Configurable LEDs	15
Front Cover Installation	15
<i>Programming</i>	15
<i>Operation</i>	16
Standard Handset Paging	16

Party Line Communication	16
All-Call Button Use	17
Alternate-Page Destination Switch Use	18
Headset Use	18
<i>Maintenance</i>	<i>19</i>
Troubleshooting	19
Service and Spare Parts	20
<i>Specifications</i>	<i>20</i>
Power	20
Ethernet	20
RTU	21
Audio	21
Mechanical	22
Environmental	22
<i>Reference Documentation</i>	<i>22</i>
<i>Approvals</i>	<i>22</i>



GAI-TRONICS®
A HUBBELL COMPANY

SP2 Fiber Weatherproof Class I Div. 2 Handset/Speaker Amplifier Station

Confidentiality Notice

This manual is provided solely as an installation, operation, and maintenance guide and contains sensitive business and technical information that is confidential and proprietary to GAI-Tronics. GAI-Tronics retains all intellectual property and other rights in or to the information contained herein, and such information may only be used in connection with the operation of your GAI-Tronics product or system. This manual may not be disclosed in any form, in whole or in part, directly or indirectly, to any third party.

This product contains copyrighted computer programs stored in semiconductor memory. These programs are copyrighted by GAI-Tronics Corporation and may not be reproduced in any form without express written permission from GAI-Tronics.

General Information

Product Overview

The GAI-Tronics SP2 station is a modular industrial multicast VoIP (Voice over Internet Protocol) communication system. The fiber weatherproof Class I Div. 2 SP2 configuration is an outdoor, multi-party, handset/speaker amplifier station using ac power with RTU control. They are constructed of engineered plastic with a powder coated aluminum front panel. A number of options are available to add to or modify station capabilities (see the [Features](#) and [Options](#) sections below).

SP2 stations connect to an Ethernet network so the loss of a single station will not adversely affect the entire system. Each station requires a 100 Mbps link to a switch or router using fiber optic cable. Isolate SP2 network traffic from other network devices to ensure the quality of SP2 audio. Properly configure network switches and routers for IGMP (Internet Group Management Protocol) snooping and multicast filtering. Maximum cable runs between fiber SP2 stations and network switches are determined by the type of fiber optic cable used in the installation.

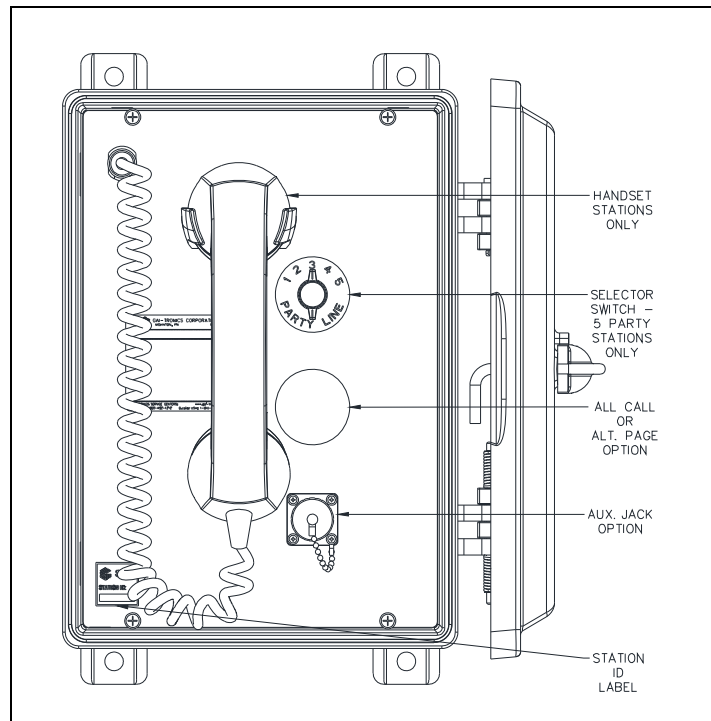

Figure 1. SP2 Station Front Panel

Features

flexible and highly configurable SMART technology featuring ALS (ambient level sensing), real time self-diagnostics, and available remote monitoring

real-time operation providing instantaneous page and party line communication

no SIP server or conference bridge requirement

one-way live paging and alarm annunciation over system speakers

distributed amplifier topology—loss of an individual amplifier will not adversely affect the system as a whole

mutual provisioning mode allows easy system deployment

high efficiency (>80%) Class D paging amplifier provides up to 30 watts of speaker output at 8 ohms

five configurable multicast channels for full-duplex conference communication with party line selector switch

eight configurable multicast channels for receiving page announcements

one isolated output for beacon activation

two isolated inputs

600-ohm audio I/O with control

configurable priority scheme allows urgent/emergency pages to override less important pages

configuration stored in non-volatile memory

field adjustable volume control for handset earpiece, headset earpiece, and speaker amplifier

configurable local and nearby speaker mutual muting to prevent acoustic feedback of live pages

configurable pre-announcement tone

off-hook and page switch timeout functionality

configurable virtual zoning ability

USB interface for field or bench configuration

universal ac power supply

engineered plastic enclosure with powder coated aluminum front panel

Options

All SP2 station options are factory installed.

24 V dc power supply

speaker amplifier only (no handset)

headset with page pressbar for loud environments

five configurable multicast channels for alternate page destinations with page line selector

All-Call push button for secondary page destination

PVC or Hytrel® handset cords in 6-, 15-, or 25-foot lengths

conformal coating for PCBA

Installation



Important Safety Instructions

Read, follow, and retain instructions—Read and follow all safety and operating instructions before installing or operating the unit. Retain instructions for future reference.



Heed warnings—Adhere to all warnings on the unit and in the operating instructions.



Attachments—Do not use attachments not recommended by the product manufacturer, as they may cause hazards.

Servicing—Do not attempt to service this unit. Opening or removing covers may expose dangerous voltage or other hazards. Refer all servicing to qualified service personnel.

 **ATTENTION**  —Install equipment without modification and according to all applicable local, national, and international electrical codes. North America—Consult the National Electrical Code (NFPA 70), Canadian Standards Association (CSA 22.1), and local codes for specific requirements regarding your installation. Install Class 2 circuit wiring in accordance with the NEC.

This equipment is suitable for use in Class I Division 2 Groups A, B, C, and D, Class II Division 2 Groups F and G, Class III, OR non-hazardous locations only. Combinations of equipment in your system are subject to investigation by the local authority at the time of installation.

 **WARNING**  —**EXPLOSION HAZARD**—Do not disconnect equipment before removing power and verifying the area is known to be non-hazardous. Avertissement—Risque d'explosion—avant de déconnecter l'équipement, couper le courant ou s'assurer que l'emplacement est désigné non dangereux.

 **WARNING**  —**In 24 V dc systems:** Do **NOT** operate this equipment from a battery charger with the batteries disconnected. Most 24 V dc battery chargers have an unloaded output of 35 to 45 volts that can quickly damage equipment designed for 24 volts nominal. Do not allow the maximum battery voltage to exceed the maximum specified input voltage.

Only trained, qualified, and competent personnel must install these enclosures. Installation must comply with state and national regulations, as well as safety practices for this type of equipment.

 **WARNING**  —**Do not disconnect equipment while energized. Ensure proper grounding to protective earthing.**

Enclosure Mounting and Cable Entries

The mounting location must be flat and provide proper clearance, rigidity, and strength to support the enclosure and all contained devices.

1. Mount the enclosure using the four 0.437-inch (11 mm) diameter holes located on the mounting flanges with 3/8-inch (M8) hardware (see [Figure 2](#)).
 - The suggested mounting height for all station enclosures is 48 inches (1219 mm) to the center of the bottom mounting holes of the enclosure.
 - SP2 stations are not supplied with conduit or cable openings.
2. Remove the front panel.
3. Drill or punch entry openings in the rear section of the enclosure (see [Figure 2](#)).
 - The station is suitable for bottom and/or side entry.
 - *Recommended:* Bottom entry prevents condensation that may form in the conduit from dripping onto the termination PCBA.
 - The minimum material (spacing) between entry holes is 1/2 inch (13 mm).

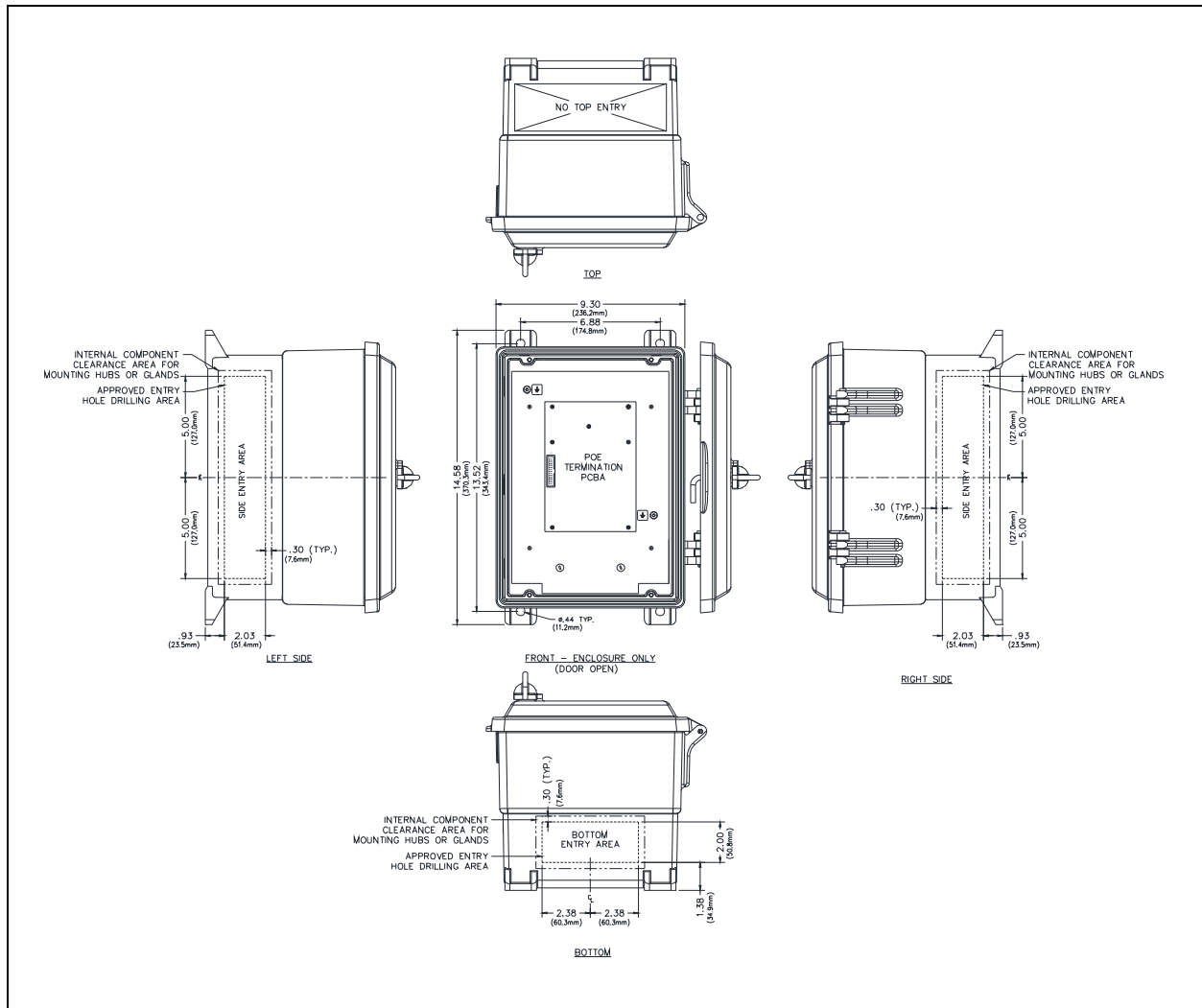

Figure 2. Suggested Wire Entry Locations

Open the Station

Complete the following steps to open the station:

1. Remove the four screws from the front panel and turn it to the left so that the interior surfaces face out.
2. Keep the wiring and ribbon cables connected.

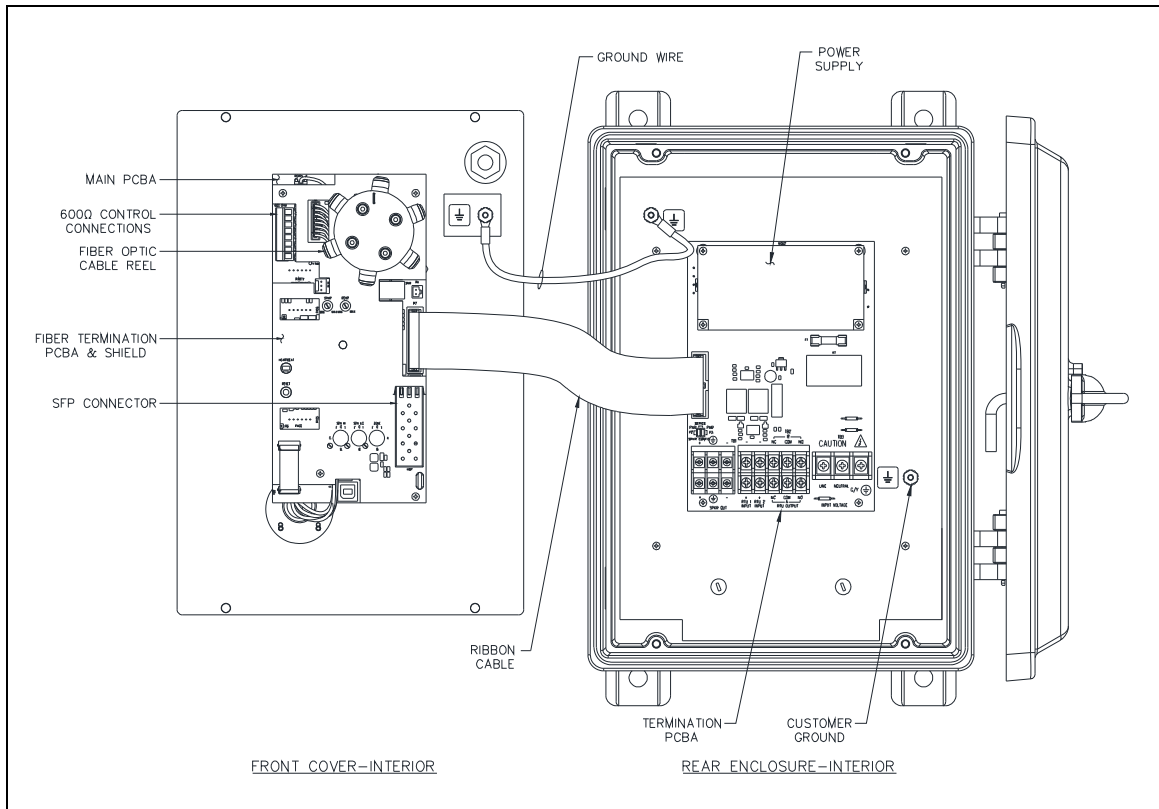

Figure 3. SP2 Fiber Weatherproof Class I Div. 2 Station—Interior View

Field Wiring and Configuration

The fiber weatherproof Class I Div. 2 SP2 station provides terminal blocks on the termination PCBA, located in the rear of the enclosure, for field wiring the power, speaker, and RTU connections. The main PCBA, mounted to the back of the front panel, provides the 600-ohm audio connection. The fiber termination board, mounted on top of the main PCBA, provides fiber optic termination for the Ethernet SFP transceiver.

NOTE: Consult the National Electrical Code (NFPA 70), Canadian Standards Association (CSA 22.1), and local codes for the specific requirements regarding your installation. Install all equipment without modification and according to the local and national codes. Install Class 2 circuit wiring in accordance with the NEC.

Station Ground

The station enclosure must have an earth ground connection:

1. Install a #6 ring lug on the ground conductor.
2. Secure it to the ground terminal located in the lower right corner at the back of the rear enclosure (see [Figure 3](#)).

Termination PCBA Connections

Install all connections as indicated in the following sections:

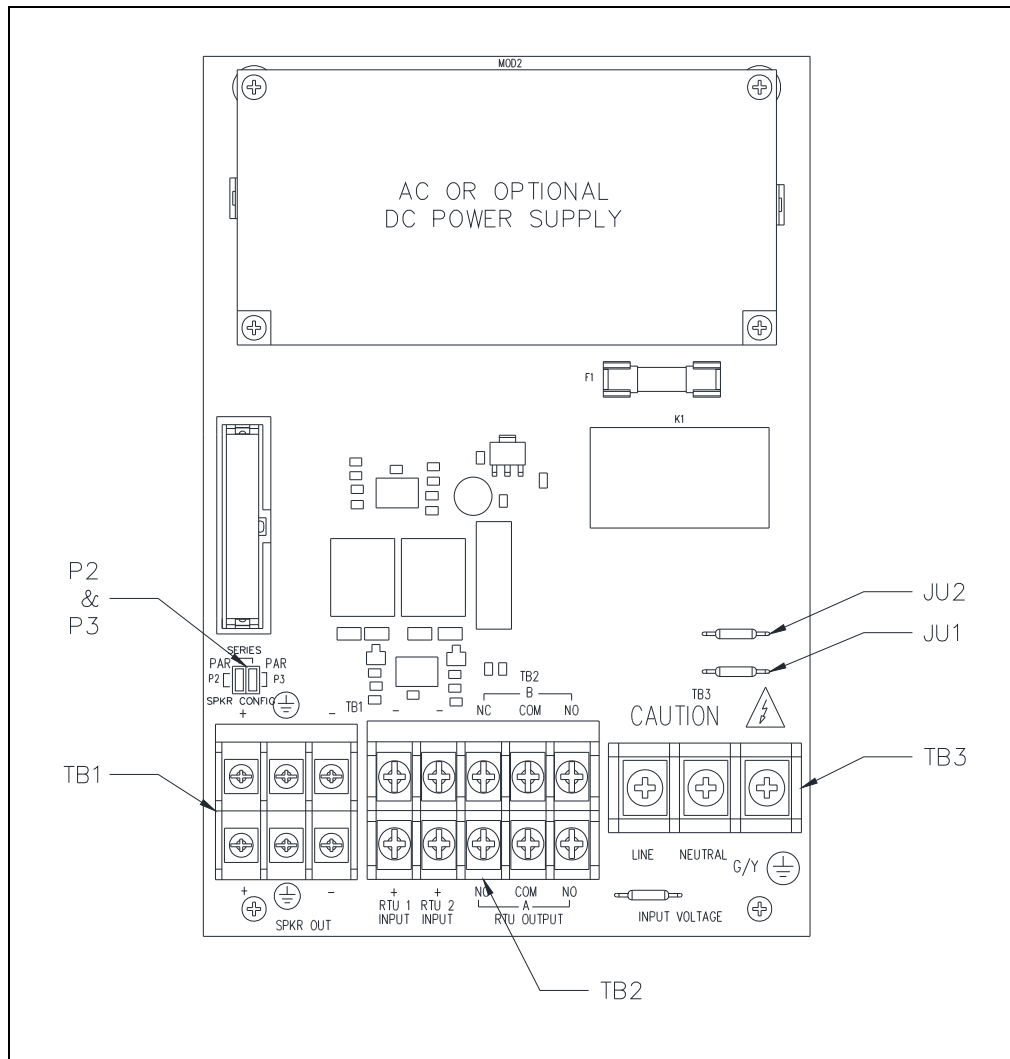

Figure 4. SP2 Termination PCBA

Direct Speaker Connection and Jumper Settings

Terminal block TB1 provides termination for the station’s 8 or 16-ohm remote speaker(s).

1. Pull the speaker cable(s) into the enclosure.
2. Install spade lugs on the wires.
3. Connect the speaker wires to terminal block TB1 (see Table 1).
4. Torque the terminal block screws to 8–10 in·lb (0.90–1.13 N·m).
5. Configure the speaker jumpers; P2 and P3, for the appropriate impedance for use with 8-ohm or 16-ohm speakers (see Figure 4 and Figure 5).

A redundant set of terminals enables connection of a second speaker branch connected in series or parallel with the primary speaker.

Table 1. Direct Speaker Connections—TB1

Pin	Label	Description
TB1-1	+	Parallel/SPEAKER A Series—Output
TB1-2	⊥	Earth Reference
TB1-3	-	Parallel/SPEAKER A Series—Output
TB1-4	+	Parallel/SPEAKER B Series—Output
TB1-5	⊥	Earth Reference
TB1-6	-	Parallel/SPEAKER B Series—Output

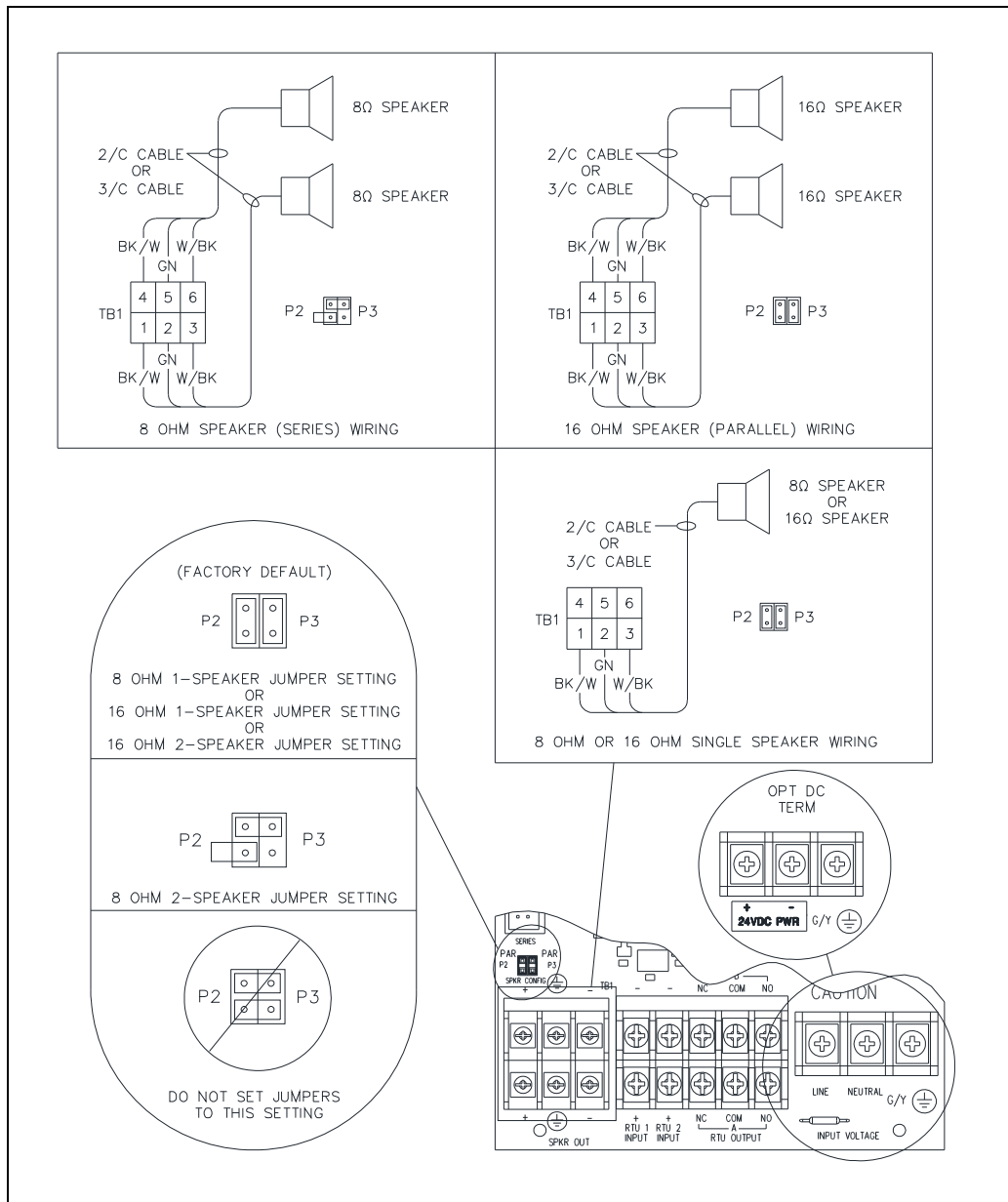

Figure 5. 8/16-ohm Speaker Impedance Configuration and AC/DC Termination at TB3

RTU Inputs

The standard termination PCBA contains two auxiliary RTU inputs. Terminate the inputs at terminal block TB2 (see Figure 4).

1. Pull the RTU input cable(s) into the enclosure.
2. Install spade lugs on the wires.
3. Connect the RTU input wires to terminal block TB2 (see Table 2).
4. Torque the terminal block screws to 8–10 in·lb (0.90–1.13 N·m).
5. Install end-of-line resistors as shown to enable RTU input-cable monitoring (see Figure 6).

Table 2. RTU Input Termination—TB2

Pin	Label	Function
TB2-1	+ RTU 1 INPUT	RTU Input 1 +
TB2-2	-	RTU Input 1 -
TB2-3	+ RTU 2 INPUT	RTU Input 2 +
TB2-4	-	RTU Input 2 -

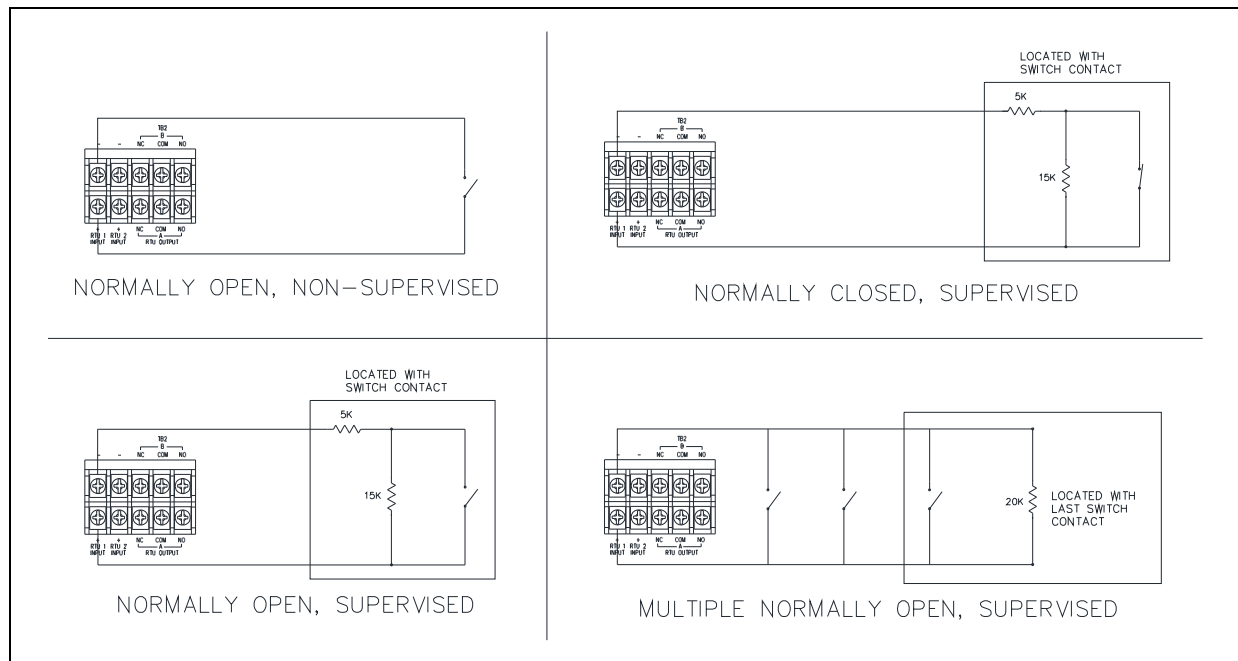

Figure 6. RTU Input Wiring Configurations for Cable Monitoring

RTU Output

Two form C contacts are provided to power a beacon (see Figure 7). Terminate the output at terminal block TB2 (see Figure 4). Configure the output for dry contact use by removing jumpers JU1 and JU2.

⚠ WARNING ⚠ —Line voltage is present at the NO contact until JU1 and JU2 are removed.

1. Pull the RTU output cable into the enclosure.
2. Install spade lugs to the wires.
3. Connect the RTU output wires to terminal block TB2 (see Table 3).
4. Torque the terminal block screws to 8–10 in·lb (0.90–1.13 N·m).

For beacon cable monitoring:

5. Install a 20-kilohm 10-watt resistor across the terminals of the beacon (see Figure 7).
6. Install jumpers at TB2 to enable cable monitoring (see Figure 7).

NOTE: Using an RTU input to monitor the beacon wiring makes it unavailable for other functions.

Table 3. RTU Output Contacts—TB2

Pin	Label	Description
TB2-5	NC A	Normally Closed Output A
TB2-6	NC B	Normally Closed Output B
TB2-7	COM A	Common Output A
TB2-8	COM B	Common Output B
TB2-9	NO A	Normally Open Output A
TB2-10	NO B	Normally Open Output B

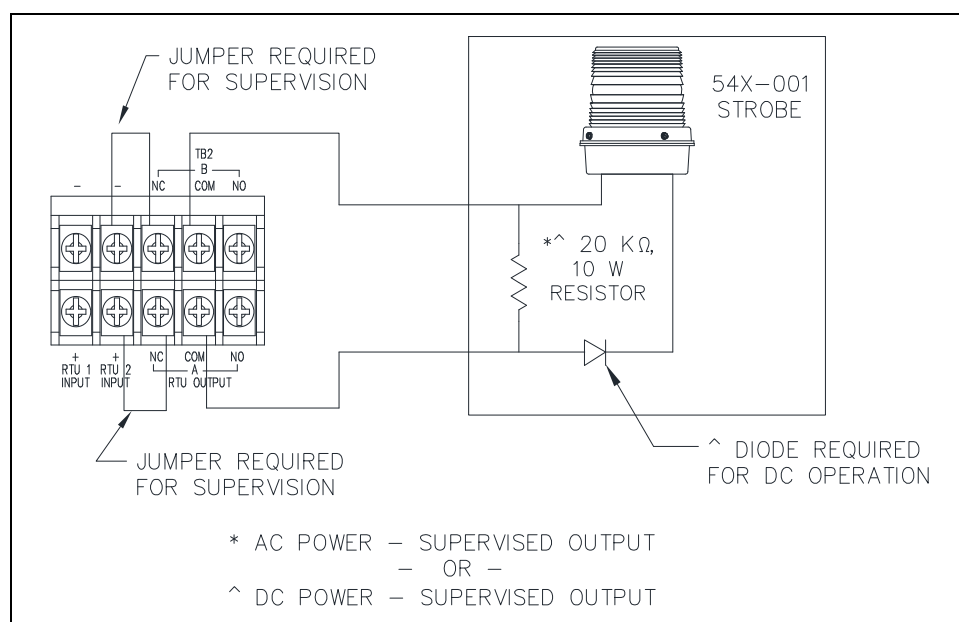

Figure 7. Supervised Output Wiring—TB2

Power

The ac or optional dc power supply is on the termination PCBA. Connect the local ac or dc power source to terminal block TB3 (see [Figure 4](#) and [Figure 5](#)):

1. Pull the cable from the power source into the enclosure.
2. Install spade lugs on the wires.
3. Connect the ac (see [Table 4](#)) or dc (see [Table 5](#)) power source conductors to terminal block TB3.
4. Torque the terminal block screws to 8–10 in·lb (0.90–1.13 N·m).

Table 4. AC Power—TB3

Pin	Label	Description
TB3-1	LINE	Positive
TB3-2	NEUTRAL	Negative
TB3-3	⊥	Earth ground

Table 5. DC Power—TB3

Pin	Label	Description
TB3-1	+	Positive
TB3-2	-	Negative
TB3-3		No Connection

Main PCBA—600-Ohm Audio I/O with Control

SP2 stations have a 600-ohm audio input to broadcast line level audio over the page line. The station broadcasts the 600-ohm input audio stream upon closure of a normally open dry contact input control. SP2 stations also provide a 600-ohm audio output for sending page line audio to a remote audio amplifier. A solid-state dry contact relay controls when the remote amplifier plays the audio.

1. Pull the cable for the 600-ohm audio I/O into the enclosure.
2. Install ferrules onto the wire ends.
3. Connect the 600-ohm audio wires to the pluggable terminal block for the 600-ohm audio I/O connection (see [Table 6](#) and [Figure 8](#)).
4. Connect the pluggable terminal block to terminal block receptacle TB1.

Table 6. 600-Ohm Audio I/O Interface Connections—TB1

Pin	Label	Description
TB1-1	IN CT1+	Input Control Positive
TB1-2	IN CT1-	Input Control Negative
TB1-3	IN AUD+	Input Audio Positive
TB1-4	IN AUD-	Input Audio Negative
TB1-5	OUT AUD+	Output Audio Positive
TB1-6	OUT AUD-	Output Audio Negative
TB1-7	OUT CT1+	Output Control Positive
TB1-8	OUT CT1-	Output Control Negative

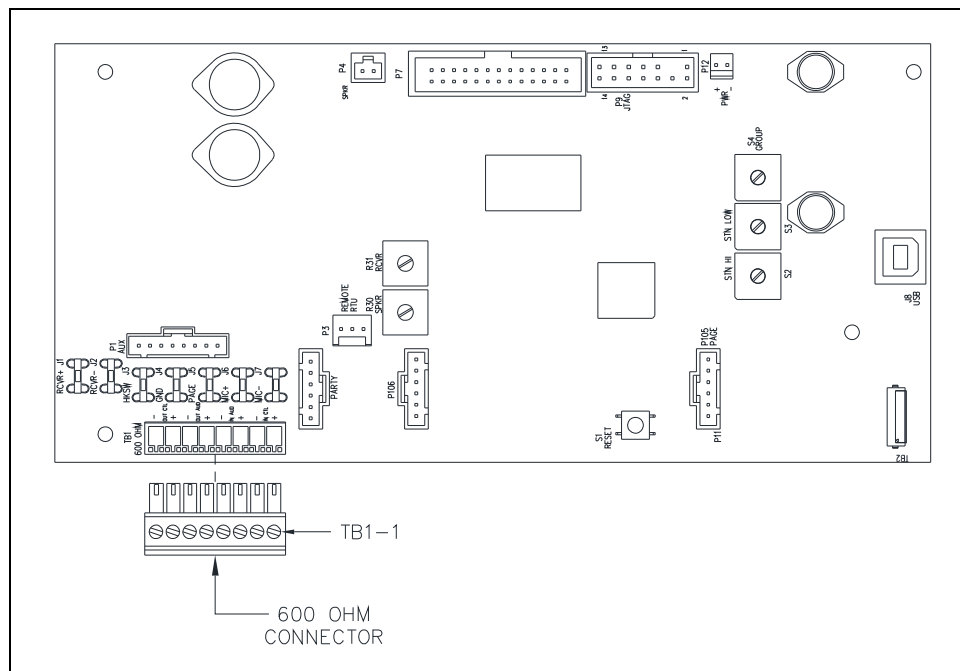

Figure 8. SP2 Main PCBA (Fiber)

Fiber Termination PCBA

The fiber termination PCBA (see Figure 9) is mounted on top of the main PCBA. Exact fiber termination is installation dependent because the fiber optic cable and SFP (Small Form-factor Pluggable) transceivers used in SP2 system installations are customer supplied. Here are the basic steps for terminating the fiber optic cable to the SP2 station:

1. Insert the SFP transceiver into the SFP receptacle (see Figure 9 and Figure 10).
2. Route the terminated fiber with the appropriate connectors into the station and over to the Fiber Termination PCBA.
3. Wrap the fiber cable around the Excess Fiber Spool.
4. Plug the fiber connector into the SFP (see Figure 10).

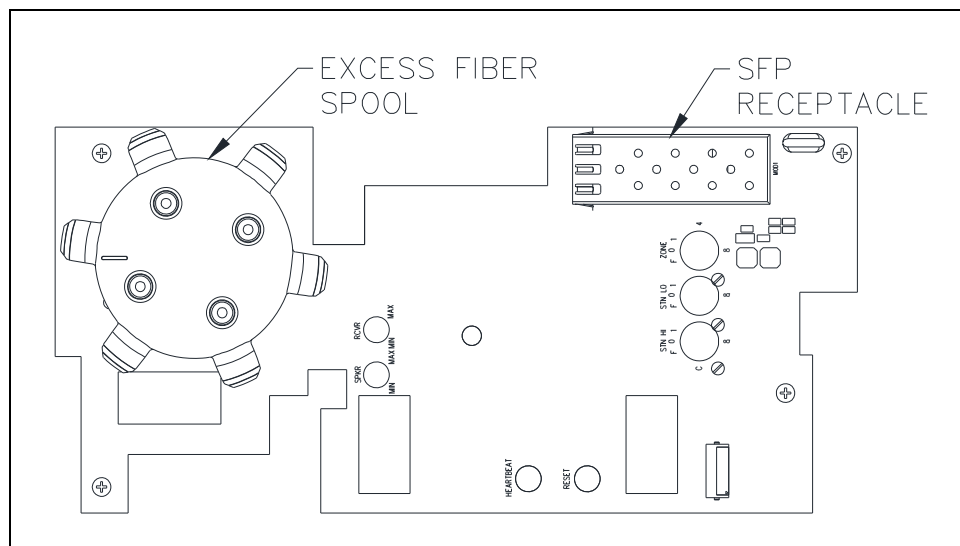

Figure 9. Fiber Termination PCBA

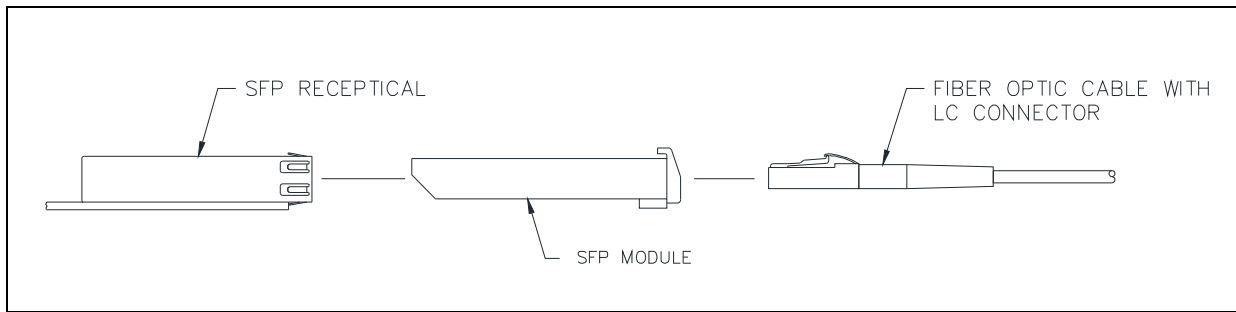

Figure 10. SFP Transceiver Insertion and Fiber Plug-in

Settings and Adjustments

Open the Station

Complete the following steps to open the station:

1. Remove the four screws from the front panel and turn it to the left to expose the interior surfaces.
2. Keep the wiring and ribbon cables connected.

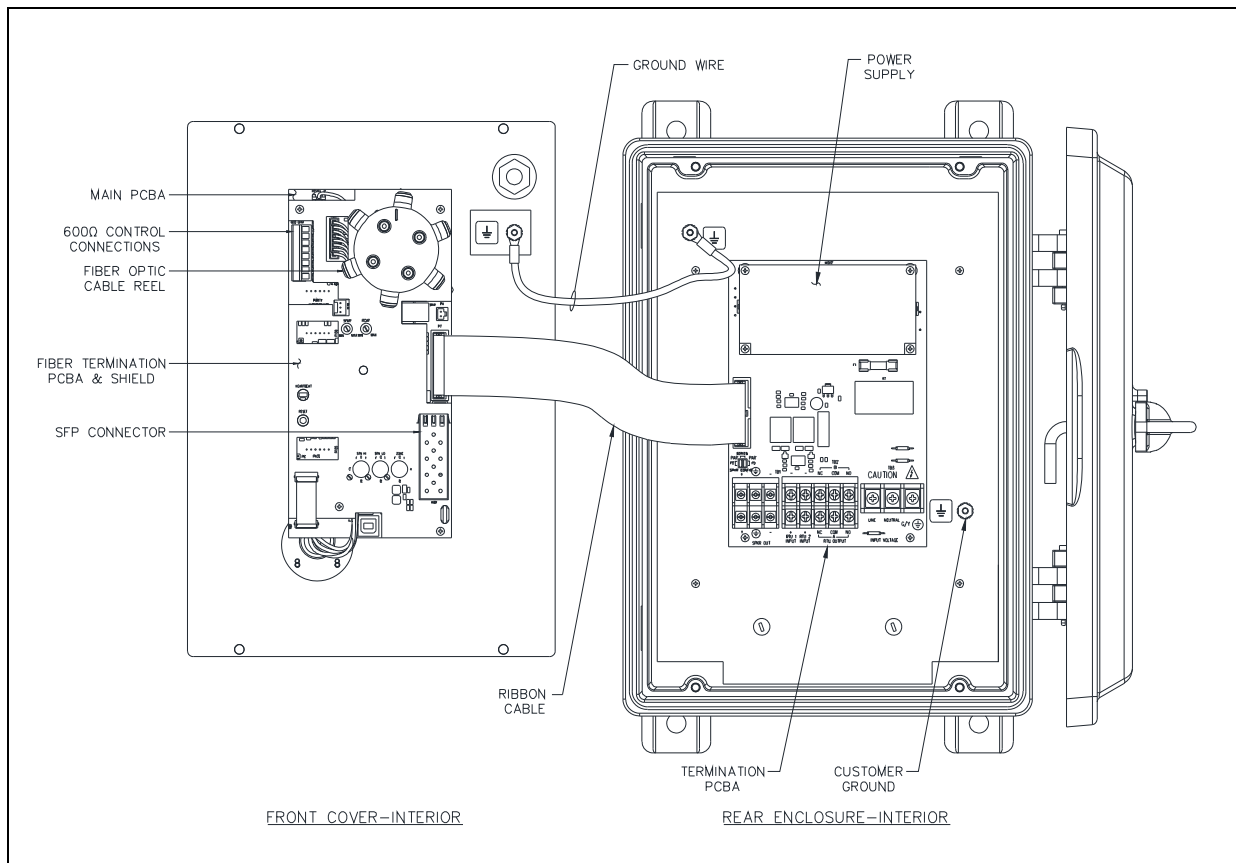

Figure 11. SP2 Fiber Weatherproof Class I Div. 2 Station—Interior View

Main PCBA Configuration

Refer to [Figure 12](#) for switch, jumper, and LED locations on the main PCBA.

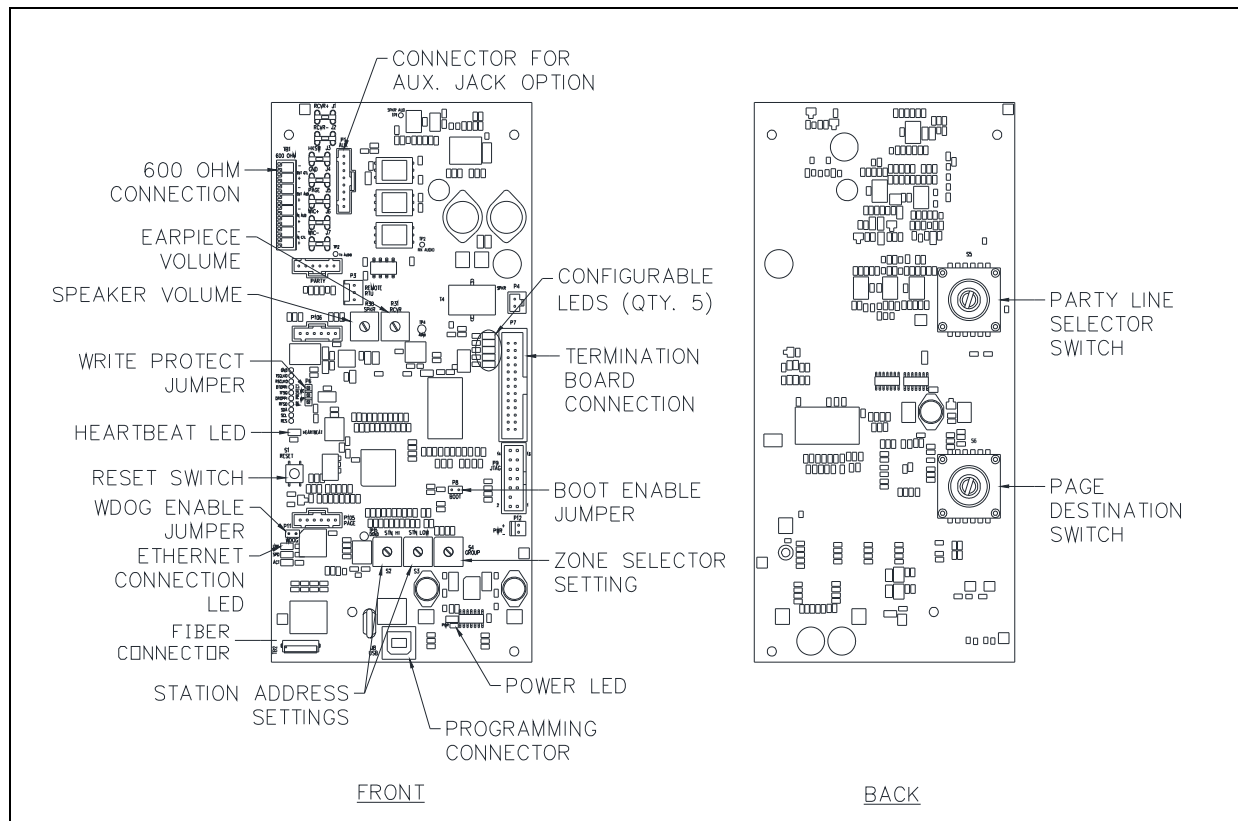

Figure 12. Main PCBA (Front and Rear Views)

Write Protect (EEPROM) Jumper

NOTE: Do NOT change this jumper in the field.

WDOG Enable (Watchdog) Jumper

Watchdog jumper, P11, enables a watchdog feature for software purposes. Do not adjust this jumper in the field. The default setting for this jumper is shorted.

Boot Enable Jumper



Jumper P8—BOOT, is for development purposes only. Do not adjust this jumper in the field. The default setting for this jumper is open.

Reset Switch

Reset switch S1 reboots the station to its initial state. All configuration settings remain programmed.

Speaker and 600-ohm Audio Output Volume

The speaker volume potentiometer, R36, adjusts the signal level to the speaker from the page line. When 600-ohm audio is also connected, R36 adjusts the volume for both. Use the CLI (Command Line Interface) to configure the output level when using 600-ohm audio without external speakers. The default setting is 4 watts from an 8-ohm speaker and 2 watts from a 16-ohm speaker.

 **WARNING**  —Maximum output power may exceed rated speaker wattage resulting in speaker damage.

To adjust the speaker or speaker and 600-ohm output volume:

1. Turn the speaker volume potentiometer, R36, fully counterclockwise.

The speaker emits an audible test-tone.

2. Slowly turn R36 clockwise to obtain the desired output volume.

The test-tone ceases three seconds after making no adjustments.

This setting is also configurable via USB or Ethernet connection using the CLI.

NOTE: Configuring this setting with the SP2 Console in a mutually provisioned system overrides this setting on the station. See the SP2 Configuration Guide, Pub. 42004-784 (see the [Reference Documentation](#) section).

Receiver Volume

Use the receiver volume potentiometer, R37, to adjust the handset volume:

1. Remove the handset from the cradle.
2. Turn the RCVR potentiometer R37 fully counterclockwise.

The receiver emits an audible test-tone.

3. Slowly turn R37 clockwise to obtain the desired output volume.

The test-tone ceases three seconds after making no adjustments.

This setting is also configurable via USB or Ethernet connection using the CLI.

NOTE: Configuring this setting with the SP2 Console in a mutually provisioned system overrides this setting on the station. See the SP2 Configuration Guide, Pub. 42004-784 (see the [Reference Documentation](#) section).

Group and Station Number Selector Switches

One *group-number* and two *station-number* hex-selector switches configure SP2 stations for *mutual provisioning* (see [Figure 12](#)). Each hex switch has a small arrow that indicates the current setting.

1. Adjust the position of the group-number selector switch to the desired group [0-F].
2. Adjust the two station-number switches to assign the station number [00–FF].

NOTE: Do NOT assign the same group/station number to more than one station.

Configure at least one SP2 station as a *master station* to utilize mutual provisioning in an SP2 system. Master stations must be assigned addresses [0.01], [0.02], or [0.03] using the selector switches. Master station(s) store the configuration of all SP2 stations on the network. Each SP2 station retrieves the mutual provisioning configuration from the master station as it powers up. See Pub. 42004-784, SP2 Configuration Guide, for detailed information on configuring SP2 stations and SP2 system mutual provisioning (see the [Reference Documentation](#) section).

Main PCBA Indicators

Power LED

The power LED illuminates when power is applied to the station, indicating the main board power supply is operational (see [Figure 12](#)).

Heartbeat LED

The Heartbeat LED flashes once communication over the LAN is established, indicating the microprocessor is operational (see [Figure 12](#)).

Ethernet Connection LEDs

Three Ethernet connection LEDs are located on the Main PCBA; link (LNK), link speed (SPD), and activity (ACT). The LNK LED is blue, the SPD LED is green, and the ACT LED is yellow. The LNK and SPD LEDs indicate an active 100 Mbs Ethernet link when **off**. The activity LED; ACT, blinks yellow to indicate Ethernet data activity (see [Figure 12](#)).

Five Configurable LEDs

Configure the five LEDs (see [Figure 12](#)) through firmware. Information for configuring these LED indicators is in the SP2 Configuration Guide, Pub. 42004-784 (see the [Reference Documentation](#) section).

Front Cover Installation

After all adjustments are complete:

1. Place the front cover onto the rear enclosure.
Do not to pinch any cables.
2. Secure the front cover using the four screws and washers provided.
3. Torque the screws to 50 in·lb (5.65 N·m).

Programming

SP2 stations are factory configured to provide basic page/party functions upon power-up. Configure stations for custom operation and/or larger system designs using the CLI or SP2 Console application. Refer to Publication 42004-784 (see the [Reference Documentation](#) section).

Operation

Standard Handset Paging

Complete the following steps to make a page announcement from an SP2 handset station:

1. Lift the handset from the cradle.
2. *If requesting conversation:* rotate the party-line selector switch (if equipped) to select an unoccupied party line.
3. Press and hold the handset pressbar (not necessary when using the optional ALL-CALL button).
4. After hearing the short *preannouncement* tone (if configured), speak directly into the microphone to broadcast the page/announcement.

NOTE: SP2 stations incorporate a noise-canceling microphone to reduce transmitted ambient noise. This requires the user to place the microphone as close as possible to their mouth.

5. *If requesting conversation:*
 1. Designate the party line selected in Step 2.
 2. Release the handset pressbar.
 3. Wait for the designated individual(s) to respond.

Full-duplex communication takes place on the party line without broadcasting over the system's speakers.

6. Replace the handset in the cradle.

Party Line Communication

To respond to a page:

1. Turn the selector switch on any SP2 station in the system to the requested party line.
2. Pick up the station handset.

Full-duplex communication takes place on the party line without broadcasting over the system's speakers.

NOTE: SP2 stations incorporate a noise-canceling microphone to reduce transmitted ambient noise. This requires the user to place the microphone as close as possible to their mouth.

3. Return the handset to the cradle following the party line conversation.

The system speakers do not broadcast party line conversations. Other individuals can join the conversation at any time by picking up a handset and rotating the party-line selector switch to the party line in use.

All-Call Button Use

Use the ALL-CALL button to page an alternate destination that is programmed for the station (see [Figure 13](#)). The All-Call option must be software configured for the SP2 station. To initiate a page using the ALL-CALL feature:

1. Lift the handset from the cradle.
2. *If requesting conversation:* rotate the party-line selector switch (if equipped) to select an unoccupied party line.
3. Press and hold the ALL-CALL button.

The ALL-CALL button eliminates the need to press the handset or headset (if equipped) pressbar.

4. After hearing the short *preannouncement* tone (if configured), speak directly into the microphone to broadcast the page/announcement.

NOTE: SP2 stations incorporate a noise-canceling microphone to reduce transmitted ambient noise. This requires the user to place the microphone as close as possible to their mouth.

5. Release the ALL-CALL button and wait for a response on the party line (if requested).
6. Return the handset to the cradle when finished.

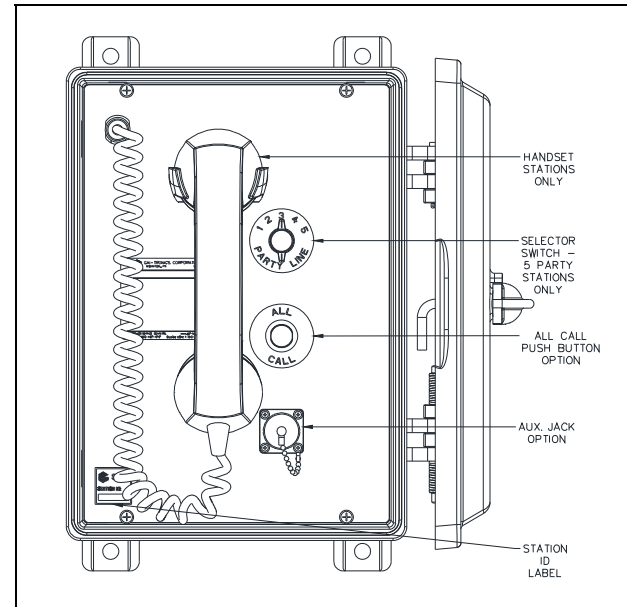

Figure 13. All-Call Button Option

Alternate-Page Destination Switch Use

Use the ALT-PAGE option selector switch to page one of five alternate destinations that have been programmed for the station (see [Figure 14](#)).

Alternate page destinations must be software configured for the SP2 station. To initiate a page using the ALL-CALL feature:

1. Lift the handset from the cradle.
2. *If requesting conversation:* rotate the party-line selector switch to select an unoccupied party line.
3. Select the desired page destination using the ALT-PAGE selector switch.
4. Press and hold the handset pressbar.
5. After hearing the short *preannouncement* tone (if configured), speak directly into the microphone to broadcast the page/announcement.

NOTE: SP2 stations incorporate a noise-canceling microphone to reduce transmitted ambient noise. This requires the user to place the microphone as close as possible to their mouth.

6. Release the handset pressbar.
7. Return the handset to the cradle or wait for a response on the party line (if requested).

Headset Use

Initiate a call with the optional headset feature as follows:

1. Attach the headset assembly to the auxiliary jack on the station (see [Figure 13](#) or [Figure 14](#)).
2. *If requesting conversation:* rotate the party-line selector switch to select an unoccupied party line
3. Rotate the ALT-PAGE selector switch (if available) or press the ALL-CALL button (if available) to select the desired optional destination for the page announcement.
4. Press and hold the headset pressbar (not necessary when using the optional ALL-CALL button).
5. After hearing the short *preannouncement* tone (if configured), speak directly into the microphone to broadcast the page/announcement.
6. Release the headset pressbar.
7. Wait for a response on the party line (if requested).

NOTE: For stations with an auxiliary jack, the Model 10401-201 Headset and 10416-103 Extension Cord allow the user to be hands-free and mobile while maintaining communication. Connecting the headset disables the handset microphone.

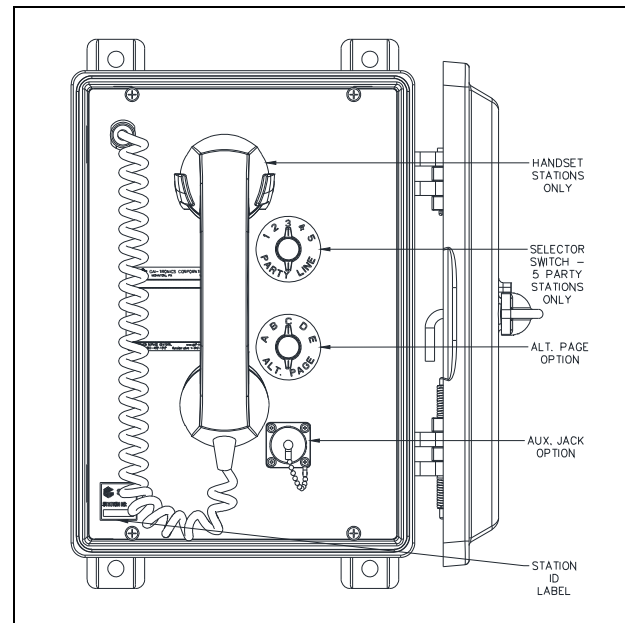

Figure 14. Alternate-Page Switch Option

Maintenance

Troubleshooting

The following table provides aid for qualified service personnel when troubleshooting problems with an SP2 station.

Problem	Solution
station not functional	<ul style="list-style-type: none"> • check wiring and cable terminations • check power supply voltage at TB3 on Termination PCBA • power LED on main PCBA illuminated • heartbeat LED blinking once per second for normal operation
network communication not functional	<ul style="list-style-type: none"> • verify LNK LED on main PCBA is off • verify SPD LED on main PCBA is off • verify IP connection settings using telnet • ping station IP address from an admin PC • verify network switch settings for IGMP snooping and multicast filtering
Handset receiver audio too high/low	<ul style="list-style-type: none"> • adjust <u>receiver volume</u> • check potentiometer R37 setting • check handset connections • check cable terminations between termination and main PCBAs • check hookswitch operation • replace handset
speaker volume too high/low	<ul style="list-style-type: none"> • adjust <u>speaker and 600-ohm audio output volume</u> • check potentiometer R36 setting • P2 and P3 termination PCBA jumper positions incorrect (see <u>Figure 5</u>) • check speaker wiring configuration on TB1 • replace speaker or driver
RTU output not functional	<ul style="list-style-type: none"> • verify no monitored output faults exist • check fuse F1 on the termination PCBA • check connected device operation
RTU input not functional	<ul style="list-style-type: none"> • verify no monitored input faults exist • check <u>RTU Inputs</u> on TB2 • check operation of connected device

Service and Spare Parts

Contact GAI-Tronics' regional service center if the equipment requires service or spare parts. An RA# (Return Authorization Number) will be issued if service is required. Ship equipment prepaid to GAI-Tronics with an RA# and a purchase order number. Repairs or a replacement are made in accordance with GAI-Tronics' warranty policy, if the equipment is under warranty. Please include a written explanation of all defects to assist our technicians in their troubleshooting efforts. Call 800-492-1212 inside the USA or 610-777-1374 outside the USA for help with identifying the nearest regional service center.

Table 7. Replacement Parts

Part No.	Description
12508-002	Screw Kit (Qty. 32)

Specifications

Power

AC Input

Input voltage 120/230 V ac (nominal), 50/60 Hz

Power factor @ nominal 120 V ac 0.5

DC Input

Input voltage 24 V dc +/-20%

Power Consumed (8-ohm load)	120 V AC	230 V AC	24 V DC
Idle	80 mA/6.6 VA	50 mA/12 VA	165 mA/4.0 W
4-watt output (default setting)	150 mA/18 VA	110 mA/25 VA	460 mA/11.0 W
30-watt output	550 mA/65 VA	350 mA/80 VA	1.95 A/46.8 W
Maximum Current Consumed (8-ohm load)	108 V AC	253 V AC	19.2 V DC
30-watt output	600 mA/65 VA	370 mA/77 VA	2.44 A/46.8 W

Current/Power requirements (+/-10%)

Ethernet

Cable fiber optic cable (customer supplied)

Fiber Optic Transceiver 100 Mbps SFP (customer supplied)

Supply Voltage 3.3 V dc

Supply Current 300 mA

Power Dissipation 1 W

Connection Speed 100 Mbps

Maximum Stations 4096

RTU

Output Control

Maximum load current:

- Output 1A (unfused)..... 8.0 A
- Output 1B (fused)..... 1.6 A

Maximum in-rush current 15 A
 Maximum voltage 250 V ac

Input Control

- Switch type..... NO or NC dry contacts
- End-of-line termination..... 20 kΩ, or 15 kΩ + 5.1 kΩ
- Cable resistance 100 Ω maximum loop resistance
- Contact closure resistance..... 1 kΩ maximum
- Open fault detection..... >65 kΩ
- Short fault detection..... <200 Ω

Audio

Handset

- Microphone..... dynamic, noise-canceling
- Receiver dynamic, hearing aid compatible
- Cord retractile, 6-foot extended, PVC
- Material..... ABS

Handset Amplifier

- Frequency response..... 250–3,000 Hz, +0/–3 dB ref. to 1 kHz
- Distortion <1.5% THD @ 1 kHz
- Receiver level..... 200 mV nominal, adjustable 100–350 mV

Headset Earpiece

Level 100 mV nominal, adjustable 50–200 mV

Speaker Amplifier

Maximum output:

- 8-ohm speaker* 30 W into 8-Ω load with –6 dBFs data signal
 adjustable to 30 W; default: 4 W @ 8 Ω
- 16-ohm speaker..... 15 W into 16-Ω load with –6 dBFs data signal
 adjustable to 15 W; default: 2 W @ 16 Ω

Frequency response..... 250–3,000 Hz, +0/–3 dB ref. to 1 kHz
 Distortion <1% THD @ 1 kHz to 24 W
 <3% THD @ 1 kHz to 30 W

600-ohm Audio Input

- Audio Level 1 V_{RMS} maximum
- Control type NO dry contact
- Control cable resistance 1 kΩ maximum loop resistance

Warranty

Equipment. GAI-Tronics warrants for a period of one (1) year from the date of shipment, that any GAI-Tronics equipment supplied hereunder shall be free of defects in material and workmanship, shall comply with the then-current product specifications and product literature, and if applicable, shall be fit for the purpose specified in the agreed upon quotation or proposal document. If (a) Seller's goods prove to be defective in workmanship and/or material under normal and proper usage, or unfit for the purpose specified and agreed upon, and (b) Buyer's claim is made within the warranty period set forth above, Buyer may return such goods to GAI-Tronics nearest depot repair facility, freight prepaid, at which time they will be repaired or replaced, at Seller's option, without charge to Buyer. Repair or replacement shall be Buyer's sole and exclusive remedy. The warranty period on any repaired or replacement equipment shall be the greater of the ninety (90) day repair warranty or one (1) year from the date the original equipment was shipped. In no event shall GAI-Tronics warranty obligations with respect to equipment exceed 100% of the total cost of the equipment supplied hereunder. Buyer may also be entitled to the manufacturer's warranty on any third-party goods supplied by GAI-Tronics hereunder. The applicability of any such third-party warranty will be determined by GAI-Tronics.

Services. Any services GAI-Tronics provides hereunder, whether directly or through subcontractors, shall be performed in accordance with the standard of care with which such services are normally provided in the industry. If the services fail to meet the applicable industry standard, GAI-Tronics will re-perform such services at no cost to buyer to correct said deficiency to Company's satisfaction provided any and all issues are identified prior to the demobilization of the Contractor's personnel from the work site. Re-performance of services shall be Buyer's sole and exclusive remedy, and in no event shall GAI-Tronics warranty obligations with respect to services exceed 100% of the total cost of the services provided hereunder.

Warranty Periods. Every claim by Buyer alleging a defect in the goods and/or services provided hereunder shall be deemed waived unless such claim is made in writing within the applicable warranty periods as set forth above. Provided, however, that if the defect complained of is latent and not discoverable within the above warranty periods, every claim arising on account of such latent defect shall be deemed waived unless it is made in writing within a reasonable time after such latent defect is or should have been discovered by Buyer.

Limitations / Exclusions. The warranties herein shall not apply to, and GAI-Tronics shall not be responsible for, any damage to the goods or failure of the services supplied hereunder, to the extent caused by Buyer's neglect, failure to follow operational and maintenance procedures provided with the equipment, or the use of technicians not specifically authorized by GAI-Tronics to maintain or service the equipment. **THE WARRANTIES AND REMEDIES CONTAINED HEREIN ARE IN LIEU OF AND EXCLUDE ALL OTHER WARRANTIES AND REMEDIES, WHETHER EXPRESS OR IMPLIED BY OPERATION OF LAW OR OTHERWISE, INCLUDING ANY WARRANTIES OF MERCHANTABILITY OR FITNESS FOR A PARTICULAR PURPOSE.**

Return Policy

If the equipment requires service, contact your Regional Service Center for a return authorization number (RA#). Equipment should be shipped prepaid to GAI-Tronics with a return authorization number and a purchase order number. If the equipment is under warranty, repairs or a replacement will be made in accordance with the warranty policy set forth above. Please include a written explanation of all defects to assist our technicians in their troubleshooting efforts.

Call 800-492-1212 (inside the USA) or 610-777-1374 (outside the USA) for help identifying the Regional Service Center closest to you.