

Installation and User Guide

Sentinel

Full keypad Hands-free telephone
1090/1099 model

GAI-TRONICS

CONTENTS

1.	Safety and Care Information.....	4
2.	Product Description	4
3.	Operation / Testing.....	5
3.1.	Making a Call	5
3.2.	Answering calls	5
3.3.	Volume adjustment	5
3.4.	Ending the Call.....	6
3.5.	Call timer.....	6
3.6.	Semi Duplex Operation	6
4.	SMART features	6
5.	Installation	7
5.1.	General	7
5.2.	Wall/Pole Mounting	8
5.3.	Flush mounting.....	11
6.	Connections	12
6.1.	Standard Connections.....	12
6.2.	Supplementary Power supply.....	12
6.3.	Optional relay outputs	13
6.4.	Optional external inputs.....	14
7.	Programming and Option Settings.....	15
7.1.	Quick Programming Guide (using a tone phone)	15
7.2.	Further programming options	16
7.3.	TMA.....	17
8.	Cleaning	18
8.1.	Normal Cleaning	18
8.2.	Stainless Steel faceplate	18
9.	Aftercare.....	18

10. Technical Specifications 19

11. CE Declaration 23

1. Safety and Care Information

- ▲ The safety of the user/installer relies on the isolation of the telephone network and not on the earthing of the case
- ▲ Please read these instructions thoroughly before starting installation. These products must be installed by competent personnel familiar with telephone installation.
- ▲ Telephone network voltages can be hazardous. Take adequate precautions when opening the case or installing. If in doubt, disconnect the telephone line elsewhere before accessing the line connections.
- ▲ For increased protection against lightning transients, attach a local earth to the main terminal block (see section 6.1)

2. Product Description

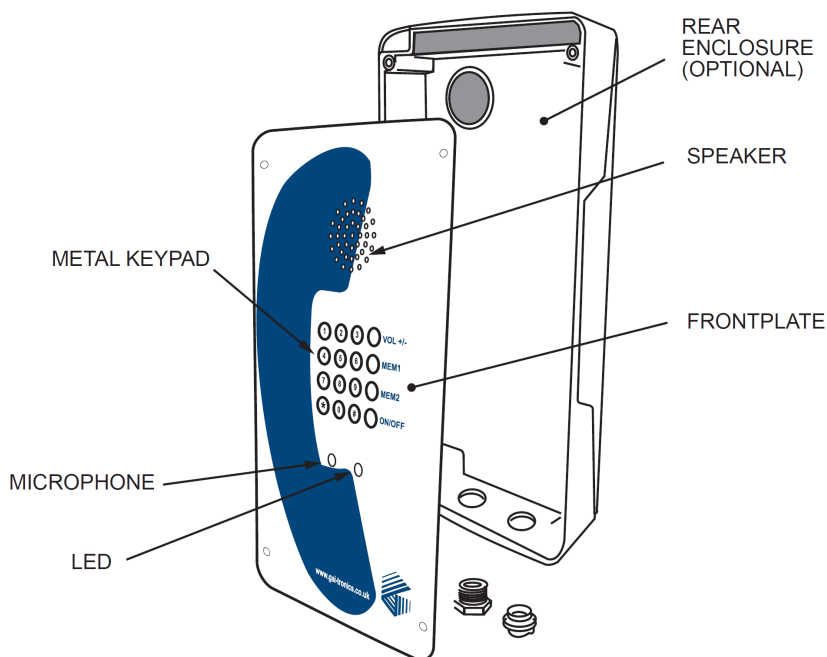

This manual describes Sentinel hands-free telephone products. These units offer high degrees of resistance to weather and abuse, having only a microphone, speaker and a rugged metal keypad mounted on a flat, metal faceplate, in place of a traditional handset. Main features include:

- 2.5mm thick stainless steel faceplate
- Waterproof speaker, protected by stainless steel mesh

- Sensitive microphone, protected by semi porous membrane and aluminium grille
- Metal button keypad, waterproof and vandal resistant
- Full numeric keypad
- 2 auto dial memories
- Volume control
- Call status LED
- Auto-dial numbers are remotely programmable
- Line powered operation (optional supplementary power supply available)
- Optional cast aluminium rear enclosure
- Optional isolated input for power supply
- SMART functionality (compatible with TMA)
- Optional relay outputs (2)
- Optional logic inputs (4)

For the full list of product features, please see the specifications in section 10.

3. Operation / Testing

Please note that, following its initial connection to the line (ie first installation), there may be a delay of up to 30s before the telephone can make an outgoing call.

3.1. Making a Call

To make a call, first press the ON/OFF button – the Sentinel will seize the line, dial tone will be heard and the Status LED will light. Then either dial the required number manually, using the numeric keys, or press one of the memory buttons (MEM1 or MEM2) to dial a pre-stored number.

3.2. Answering calls

To receive a call, press the ON/OFF button when ringing is heard.

3.3. Volume adjustment

During a call, the call volume can be adjusted by pressing the VOL button. Repeatedly pressing the VOL button will cycle the volume between 3 settings (low, mid and high). The telephone does not remember the setting from one call to the next, and will always start each new call at the mid level.

3.4. Ending the Call

To end the call, press the ON/OFF button. The unit will also close down and release the line on receipt of the following signals, usually when the remote party clears:

- Line polarity reversal
- A line break (sometimes referred to as a “k break”).
- Receipt of exchange call progress tones (see section 10 for specification)

3.5. Call timer

The phone has a programmable call timer that can limit the maximum call duration.

When ON, the timer forces the phone back off line after the preset time. This prevents the line remaining tied if the neither party ends the call. The timer is factory-set to 7mins by default, but can be set to any value (up to 2³/₄hrs) or disabled. See section 7.2.1.

3.6. Semi Duplex Operation

The Sentinel is semi duplex, with automated switching between transmit and receive depending on which signal is the stronger. It therefore requires an adequate signal level to be able to switch into receive mode. This level may vary according to ambient noise levels at the Sentinel telephone, but we would recommend ensuring that the incoming signal level received at the Sentinel telephone is at least -35dBm.

This level may have to increase if the ambient noise level at the Sentinel telephone is high, and in any event correct operation cannot be guaranteed in ambient noise levels exceeding 80dBA.

Semi duplex operation can also be affected if the impedance of the telephone line differs significantly from the pan-European standard – see section 10.

4. SMART features

This family of products has a wide range of intelligent features including:

- Monitoring of faults and health status
- Remote programming of auto-dial numbers and configuration parameters
- Alternate day / night autodial numbers
- Call logs for calls made to and from the telephones¹

¹ Called Party Answered signalling (CPA), ie a reversal of line polarity when an outgoing call is answered, is required to ensure accurate recognition of call connection and answer delay times. CPA is a telephone line service and may not be available from all telecom service providers.

These features are all available over standard, 2 wire telephone lines with no external power required at the phone.

To use these features, GAI-Tronics provide a Telephone Management Application (TMA) available separately, see section 7.3.

5. Installation

5.1. General

IMPORTANT

All possible measures must be taken to ensure water, fluid or dust does not contaminate the internal components of the telephone whilst unpacking, preparing and installing the telephone in inclement weather conditions or by negligence.

Failure to do so may invalidate your warranty.

These telephones are supplied without connection leads – cabling to the telephone network must be supplied and installed by the installer. Because of this, extra precautions must be observed: installers must ensure that they have the permission of the owner of the PABX or telephone network to which the telephone is to be connected, and that installation is carried out by competent personnel. Where the telephone faceplate is mounted into an enclosure or recess other than the standard GAI-Tronics backbox, then additional care must be taken that wiring and proximity to conducting surfaces complies with the requirements of the R&TTE Directive - 1999/5/EC.

Contact GAI-Tronics if installation service is required.

5.2. Wall/Pole Mounting

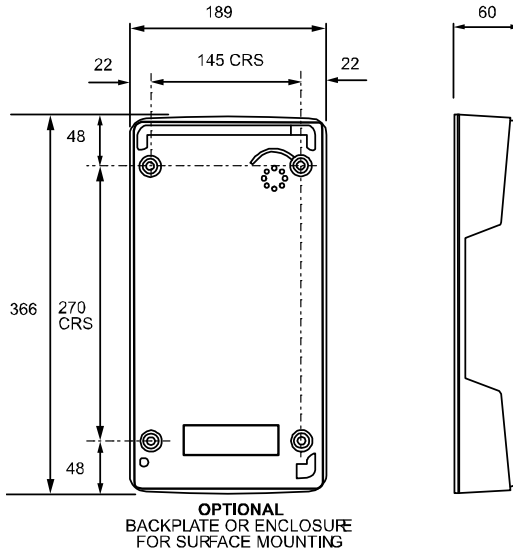

When wall or pole mounted, Sentinel telephones must be fitted inside a dedicated rear enclosure, available separately.

Before mounting the telephone, check the cable routing and requirements. If glands are required, fit them to the case as follows:

1. Remove the RED blanking plug leaving the other (usually BLACK) in place.
Only fit a second gland if a separate cable is required to the phone (for example for an additional hook contact).

2. Select the appropriate sized gland:
Use the smaller gland for cables diameters 4 - 7mm.
Use the larger gland for cable diameters 8 - 13mm.

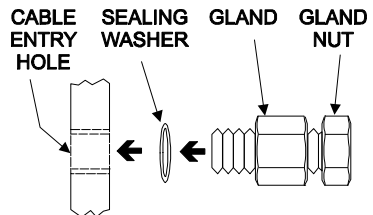

3. From the outside of the case, insert the selected gland into the threaded cable entry hole and tighten, so that its sealing washer is compressed against the enclosure surface.
4. Ensure that both cable entries are sealed with either a gland or a black blanking plug as described.
5. Proceed with chosen mounting method below

5.2.1 Wall mounting

1. Using a suitable tool, punch out 4 holes in the rear enclosure, taking care not to damage or dislodge the plastic bushes. Only four of the eight holes are required - the outer ones are recommended. The inner holes are provided to be compatible with older-style mounting posts, and should be left intact if not used. If the inner holes are used they must be fitted with the supplied plastic bushes.

WARNING: *Your warranty will be invalidated if :-*

1. *Any fixing hole made in the rear enclosure is left unused.*
 2. *Any additional holes are drilled into the telephone enclosure.*
 3. *Plastic bushes are not used on all fixing holes.*
-

2. Mark the wall with hole centres based on the dimensions shown (145 x 270mm). If necessary offer the rear enclosure up to the wall to check alignment. Do not use the enclosure as a template for drilling.
3. Drill holes in the wall on the marked positions. Select appropriate screws, wall plugs etc., for the type of wall, bearing in mind that the weight of the complete phone is around 4kg.

IMPORTANT: USE ONLY *countersunk-headed fixing screws. Check that screws seat properly in the plastic bushes to ensure a watertight seal. Do not use excessive tightening force, as this may crack the case.*

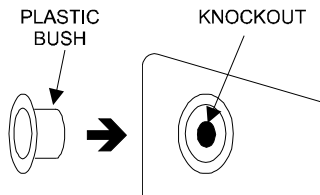

4. Ensure that all four plastic flanged bushes are in place and the rear enclosure is screwed tightly to the surface to prevent any water ingress through the punched holes.
5. Complete the installation by making the appropriate connections (section 6) and re-fitting the face plate.

IMPORTANT: avoid the use of power tools. Spinning the fixing screws too quickly can cause a rapid increase in heat which can cause them to seize as a result of galling or cold-welding.

5.2.2 Pole mounting

Kit No 100-02-0208-001

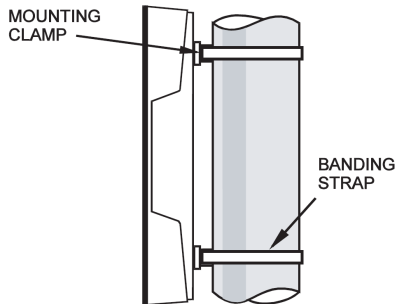

This accessory is for mounting GAI-Tronics telephones on to the side of round poles of 100mm to 200mm diameter, or on to square or rectangular section uprights of 100mm to 150mm across the mounting surface.

NOTE:

Banding straps (large scale worm-drive clamps) are not included in this kit and must be obtained separately. For details of where banding can be obtained, refer to GAI-Tronics.

1. Using a suitable tool, punch out the 4 **outer** holes in the rear enclosure, taking care not to damage or dislodge the plastic bushes.
2. Attach the pole mounting clamp assemblies to the rear enclosure using the M6 x 25 screws provided, pushing the screws through from inside the phone.
3. Tighten nuts to a torque of 4.5Nm max.
IMPORTANT: avoid the use of power tools. Spinning the nuts too quickly can cause a rapid increase in heat which can cause the nuts to seize as a result of galling or cold-welding.
Note: only use the outer four holes, and ensure that the screws seat properly in the plastic bushes to avoid water ingress.
4. Ensuring that the glands are at the bottom, pass a proprietary banding strap round each of the pole mounting clamps and the support pole. Tighten securely.
5. Continue the installation by making the appropriate connections (section 6) and fitting the Sentinel face plate to the rear enclosure.
IMPORTANT: avoid the use of power tools. Spinning the fixing screws too quickly can cause a rapid increase in heat which can cause them to seize as a result of galling or cold-welding.

6. Re-tighten the straps firmly and trim off any excess band material. For security the driving head of the band may also be sawn off.

5.3. Flush mounting

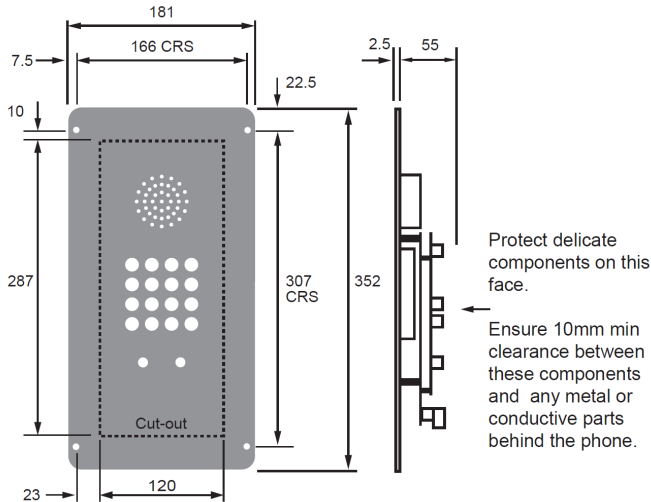

IMPORTANT:

If not mounted in the GAI-Tronics metal rear enclosure, the rear face of the Sentinel telephone must be installed so that its delicate components cannot be damaged and to ensure that there is a minimum 10mm clearance between them and any metal or conductive parts behind.

Note that it is the installer's responsibility to prevent moisture coming into contact with the electronics and connections on the back of the faceplate.

To flush-mount the telephone to a wall:

1. Prepare a recess (at least 55mm deep) in the wall according to the dimensions shown.
2. Mark the wall with hole centres based on the dimensions shown (166 x 307mm). If necessary offer the faceplate up to the wall to check alignment. Do not use the telephone as a template for drilling.
3. Drill holes in the wall at the marked positions. Select appropriate screws, wall plugs etc., for the type of wall, bearing in mind that the weight of the complete phone is around 1.5kg.

- Route the cable to within the recess, and make connections to the telephone as shown in section 6.

Secure the telephone to the wall taking care not to trap any wires. Note that the gasket on the rear of the faceplate is intended to make a weather seal when compressed against a smooth surface. Do not rely on this gasket to keep water out if mounting directly to rough surfaces such as brickwork – in these cases use additional sealant around the edges to ensure a weatherproof seal.

6. Connections

6.1. Standard Connections

Connect the telephone line A and B to the main terminal block CON1 as shown.

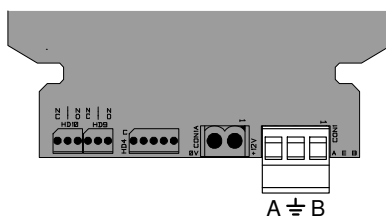

The centre earth terminal is intended for connection to a local earth to provide common mode protection from lightning transients. **If this terminal is not earthed there is an increased risk that the telephone could be damaged by line-born transients.**

Note that user safety from the telephone network is provided by isolation and does not rely on this earth connection.

Note: Conductor sizes to be 0.5mm-2.5mm² (flexible cable); 0.5-4.0mm² (solid cable) The terminal block can be disconnected from the circuit board for easier installation

Cabling must not infringe EC Low Voltage Directive (LVD) 2006/95/EC.

6.2. Supplementary Power supply

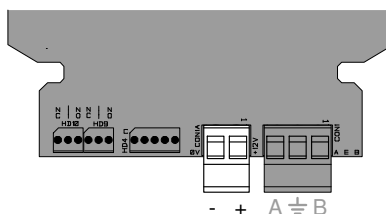

GAI-Tronics hands-free telephones can be equipped with a supplementary power supply, required to power the induction loop (if fitted), external relays (if fitted) and generally to provide increased audio output level.

The standard telephone does not require this supplementary supply for normal operation, but note that ringing on exchanges with low ring voltages (<40Vac) may be unreliable without a supplementary supply.

The supplementary power input is provided on CON1A as shown and must be an earth-free isolated supply of 12V dc (250mA min) to suit the power requirements of the required peripherals, suitable for connection to a TNV-3 circuit.

Note: A common supply cannot be used for multiple telephones unless the unit is equipped with an isolated power supply input. This is available as an option if specifically ordered. Contact GAI-Tronics for details.

CAUTION: occasional problems have been observed with certain 3rd party switched-mode power supplies. GAI-Tronics cannot accept responsibility for the performance of any 3rd party supplied power supply. If in doubt always use a power supply provided by GAI-Tronics.

6.3. Optional relay outputs

GAI-Tronics hands-free telephones can be equipped with external relay outputs, controlled by the telephone software. Note – these optional connections are only available if specifically ordered, and are not field upgradeable. A supplementary power supply (see section 6.2) is also required. Contact GAI-Tronics for details.

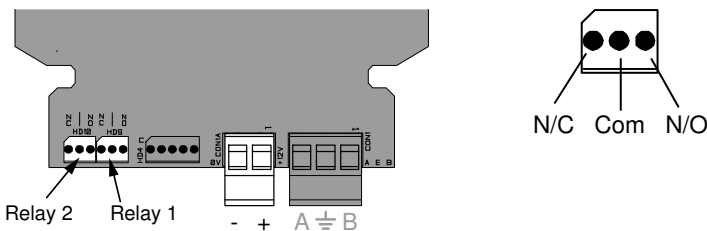

The additional outputs are provided on HD9 & HD10 as shown and are isolated SELV outputs as defined by EN 60950-1.

To comply, the installer must ensure that any connections are within SELV limits.

Relay ratings / SELV limits: 30Vdc, 42.4V peak (resistive load)

Max switching current: 3A

6.4. Optional external inputs

GAI-Tronics hands-free telephones can be equipped with 4 external inputs, which can be used to generate call-in events or alarm reports (using TMA). Note – these optional connections are only available if specifically ordered and are not field upgradeable. Contact GAI-Tronics for details.

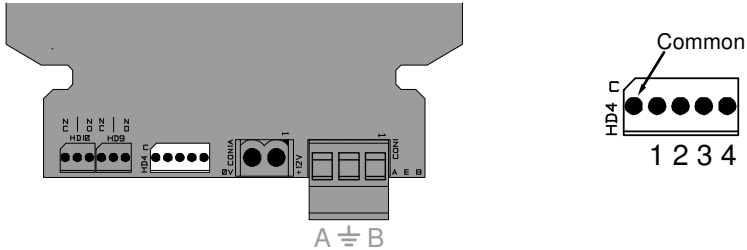

The inputs are provided on HD4 as shown, and are also labelled on the circuit board. Control inputs are for connection to voltage free contacts only. Internal pull-up resistor source current = 33 μ A. These inputs form part of a TNV3 circuit and precautions must be taken to prevent hazardous voltages being applied to these circuits.

NB these inputs are not isolated from the telephone network.

7. Programming and Option Settings

Programming and option setting is done remotely by sending commands down the telephone line to the unit. This can be done by either using a tone phone, or by using GAI-Tronics TMA - a PC software application.

7.1. Quick Programming Guide (using a tone phone).

	Stage	What you do	What you hear back	Notes
1	Call the SMART phone	Dial the number of the phone to be programmed	ringing	The number of rings before auto-answer is programmable (see below), but is factory set to 5
		Wait for it to auto-answer	A single tone (beep), then ringing resumes	
2	Put the phone into maintenance mode	Enter *	Ringings stops	If you still hear ringing, either the phone hasn't auto-answered yet, or it didn't hear the *. Wait a second and try again.
3	Enter the access PIN	Enter **0000	No response	If you don't hear 6 tones in response to *20, it means the PIN was not recognised. Enter *# and try again.
4	Confirm access	Enter *20	6 tones	
5	the phone is now in maintenance mode and ready to receive programming commands, eg:			
	Program memory 1	Enter *1 01 <number> #	A single tone	If you make a mistake, or hear 2 tones instead of one, just repeat the command.
	Program memory 2	Enter *1 02 <number> #	A single tone	
6	Save and close down	Enter *99	A single tone	The final tone confirms that the changes have been saved.

Eg, to program memory 1 to 01283 500500, use

*101 01283500500 #

7.2. Further programming options

In addition to programming auto-dial numbers, several other features can be programmed using a tone-phone.

7.2.1 Time-out

The call time out is factory set to 7 minutes, meaning that the phone will drop the call and go back on hook electronically after this period even if a call is in progress. This feature is provided to guard against the handset being left off hook and tying up the line.

The timer can be set in increments of 10s from 60s to 9980s by entering the code *50, followed by the required timeout divided by 10s, followed by #.

For example to set the timer to 3 minutes enter *50 18 # (3min is 180s, 18 is 180/10).

This command must be entered between entering the PIN and closing the phone down with *99 (ie during step 5 of the quick programming guide above).

To disable the timer use a value of 999, ie *50 999 #.

The phone will respond to a successful command with a single tone.

7.2.2 Inserting a pause into an auto-dial number

To enter a pause (approx 1 second gap) into a dial number, use the digits *1.

For example to program 9 <pause> 12345 into memory 1, use

```
*101 9 *1 12345 #
```

This command must be entered between entering the PIN and closing the phone down with *99 (ie during step 5 of the quick programming guide above)

7.2.3 Auto-answer behaviour

To set a SMART telephone to automatically answer in a voice call, use

```
*70 0 #
```

To set a SMART phone to answer immediately, and only ring after auto-answering (ie for silent monitoring), use

```
*70 240 #
```

The actual formula for rings before and after auto-answer is

```
*70 n #
```

Where n is a number between 0 and 255 calculated as follows:

$$n = 16 \times R_a + R_b,$$

where R_a is the number of rings after autoanswer, and R_b is the number of rings before autoanswer

This command must be entered between entering the PIN and closing the phone down with *99 (ie during step 5 of the quick programming guide above)

7.2.4 Receive level

To change the receive level, use

*72 n #

Where n is the level in dB, minimum 10, maximum 31, the factory default setting is 26.

This command must be entered between entering the PIN and closing the phone down with *99 (ie during step 5 of the quick programming guide above)

CAUTION - changing this level may cause the phone to be too loud or too quiet, and in extreme cases could affect the semi duplex operation.

To set the phone back to its factory default volume setting use

*72 26 #

7.3. TMA

GAI-Tronics TMA is a fully featured software application (Telephone Management Application) for Windows™, offering the facilities to program, maintain, monitor and report on all types of GAI-Tronics SMART products.

Full details on the configuration and use of TMA are provided with the package itself.

Contact GAI-Tronics for further details.

TMA part numbers:

TMA package (UK): 100-02-0309-001

TMA package (Europe): 100-02-0309-002

Each package includes the TMA software (including comprehensive help documentation and installation instructions), external modem and dongle.

8. Cleaning

Recommended cleaning methods are outlined below:

8.1. Normal Cleaning

For normal cleaning we recommend "Virosol", manufactured by Clover products.
Carefully follow manufacturer's instructions for storage, handling and use.

8.2. Stainless Steel faceplate

The stainless steel faceplate should be cleaned regularly especially if the unit is in a marine environment. The stainless steel may show signs of discolouration or rust – this will not damage it or impair performance but may look unsightly and can be cleaned using normal cleaning agents as above.

9. Aftercare

The purchase of your GAI-Tronics product does not end our commitment to you.

In addition to our warranty obligations, GAI-Tronics are able to offer various levels of maintenance packages, installation and commissioning packages and technical support, from ad-hoc repairs to full maintenance contracts.

By choosing GAI-Tronics as your aftercare provider you are ensured of manufacturer expertise and ISO 9001-certified quality control standards throughout the life of the product.

We can also supply a full range of accessories including mounting posts, beacons and high-volume sounders.

Contact GAI-Tronics for details. www.gai-tronics.co.uk

10. Technical Specifications

Operational Requirements	
Systems.	<ul style="list-style-type: none"> • Analogue Public Switched Telephone Network (PSTN) • Private Automatic Branch Exchange (PABX)
Not suitable for connection to:	<ul style="list-style-type: none"> • Payphone extensions • Public Emergency Telephone System (PETS)
Telephone line parameters (without supplementary power supply)	<ul style="list-style-type: none"> • Ring Voltage: 40V to 100V rms, 20Hz to 50Hz • Line voltage 20 to 70 Vdc • Loop current $\geq 25\text{mA}$ • Max loop resistance 2800Ω • Line impedance $270R + 750R 150nF$ as defined in ETSI standard ES 203 021 (previously TBR21)
With supplementary power supply	<ul style="list-style-type: none"> • Ring Voltages down to 30V • Loop current down to 15mA
<p>Note: these telephones have been designed for pan-European single terminal connection to the PSTN. However, due to differences between the individual PSTNs & PABXs provided in different countries, this does not, of itself, give an unconditional assurance of successful operation on every PSTN or PABX termination point.</p>	
Product features	
Power supply	<ul style="list-style-type: none"> • Can operate from line power only. • Supplementary power supply input (non-isolated) provided as standard. 12Vdc (± 1) @ 250mA min. • Supplementary power will enhance ringing and audio quality. • Supplementary power is required for external relay options. • Isolated power supply input is available as an option • GAI-Tronics cannot accept responsibility for the performance of any 3rd party supplied power supply. If in doubt always use a power supply provided by GAI-Tronics.
Hookswitch	Electronic with no external moving parts
Ringer loudness	80dBA @ 1m

Call termination	<p>Calls started from the hands-free telephone can automatically terminate in one of three ways if the called party hangs up:</p> <ul style="list-style-type: none"> • Polarity reversal of DC feed • K-break (interruption of loop current > 50ms) • Call progress tone: a tone received on the line, in the frequency range 280 – 550Hz, either: <ul style="list-style-type: none"> ○ A continuous tone for 5s, or ○ A repeated tone (“beep”) for 5 identical repetitions. <p>Note that, for reliable operation, progress tone level should be between -10dBm and -35dBm, measured at the telephone.</p>
Keypad	<p>Weather resistant Vandal resistant 16 metal buttons on 4 x 4 matrix, comprising:</p> <ul style="list-style-type: none"> • 12 numeric keys (0-9, *, #) • 2 memory dial buttons (MEM1 & MEM2) • ON/OFF button • Volume button (cycles the receive level between normal level, -6dB and +6dB)
Dialling and recall mode	MF only. TBR only.
Monitored faults and sensors	<ul style="list-style-type: none"> • Brown out (power failure) • Stuck button • Call log full • 4 auxilliary inputs (optional)
Parameters configurable with TMA	<ul style="list-style-type: none"> • Autodial numbers - including time-switched alternate numbers • Speech receive level. • Rings before / after auto-answer • Time out (default 7 minutes) • Mute before dial • DTMF detection window
Monitoring method	<ul style="list-style-type: none"> • Remote polling (initiated by TMA) • Call-in (initiated by the telephone at a preset time)

Environmental limits	
Temperature:	Operating: -20°C to +60°C Storing: -40°C to +70°C
Relative Humidity	Up to 95% (non-condensing)
Ingress Protection	IP65 (from the front only unless fitted in the GAI-Tronics rear enclosure) to EN60529:1992 – Degrees of protection provided by enclosures.
Impact resistance	IK08 to EN 62262 (to front face only unless fitted in the GAI-Tronics rear enclosure)
Physical characteristics	
Faceplate material	Stainless steel, brushed finish.
Rear enclosure material	Aluminium. Powder coated.
Weight	1.5kg without rear enclosure 4kg with rear enclosure
Dimensions	181W x 352H x 45D without rear enclosure 189W x 366H x 60D with rear enclosure See section 5

Recycling information	<p>The symbol shown here and on the product means that the product is classed as Electrical or Electronic Equipment and should not be disposed with other household or commercial waste at the end of its working life.</p> <p>The Waste of Electrical and Electronic Equipment (WEEE) Directive has been put in place to recycle products using best available recovery and recycling techniques to minimise the impact on the environment, treat any hazardous substances and avoid the increasing landfill.</p> <p>Business users should contact their suppliers and check the terms and conditions of the purchase contract and ensure that this product is not mixed with other commercial waste for disposal.</p>	
-----------------------	---	--

Compliance to standards	
European Directives	1999/5/EC – European Radio & Telecommunications Terminal Equipment Directive.
	2011/65/EC - Restriction of the use of certain hazardous substances in electrical and electronic equipment (recast) (RoHS 2) Directive
	2002/96/EC - Waste Electrical and Electronic Equipment (WEEE) Directive
EMC	EN 55022 – Information technology equipment. Radio disturbance characteristics. EN 55024 – Information technology equipment. Immunity characteristics. EN 50121-4 - Railway applications, emission and immunity
Safety	EN 60950-1 – Specification for information technology equipment, including electrical business equipment. BS 6789 Pt.2:1984 (Clause 7.5) – Acoustic Shock. Apparatus with loudspeaking facilities for connection to U.K public switched telephone networks. EN 50371 - Generic standard to demonstrate the compliance of low power electronic and electrical apparatus with the basic restrictions related to human exposure to electromagnetic fields (10 MHz - 300 GHz). General public.
Telephony	ES 203 021 - Access and Terminals (AT); Harmonized basic attachment requirements for Terminals for connection to analogue interfaces of the Telephone Networks. EN 301 437 - Terminal Equipment (TE) - Attachment requirements for pan-European approval for connection to the analogue Public Switched Telephone ES 201 729 - Public Switched Telephone Network (PSTN) - 2-wire analogue voice band switched interfaces; - Timed break recall (register recall); - Specific requirements for terminals BS6789 Pt.2:1984 – Apparatus with loudspeaking facilities for connection to U.K public switched telephone networks.
Lightning and transients	ITU-T recommendation K.21 - Enhanced surge protection.



11. CE Declaration

GAI-TRONICS

A Division of Hubbell Ltd

EC Declaration of Conformity



We, GAI-Tronics (a division of Hubbell Ltd.), of Brunel Drive, Stretton Business Park, Burton upon Trent, Staffordshire, England, DE13 0BZ, declare under our sole responsibility, that the following product is in conformity with the directives listed below and hold the relevant technical documentation at the above address.

Product description	Sentinel Weather Resistant, Full keypad, Handsfree Telephones incorporating 999-02-1090-xxx PCB
----------------------------	---

EC Directives
1999/5/EC – Radio Equipment and Telecommunications Terminal Equipment (R&TTE) Directive
2011/65/EC - Restriction of the use of certain hazardous substances in electrical and electronic equipment (recast) (RoHS 2) Directive

Date of issue	Name/Job Function of authorised signatory	Signature of signatory
5 December 2013	R Rumsby Engineering Manager	

GAI-TRONICS

A division of Hubbell Ltd.

Brunel Drive
Stretton Park
Burton on Trent
DE13 0BZ
England

Tel: 01283 500500

Fax: 01283 500400

www.gai-tronics.co.uk

The policy of GAI-Tronics is one of continuous improvement, therefore the Company reserves the right to change specifications without notice