

### Temperature Range of Adaptors and Reducers:

- a) Standard Product - Without O-Ring fitted: - 60°C to +160°C
- b) Optional Nitrile O-Ring fitted: - 60°C to +80°C
- c) Optional Silicon O-Ring fitted: - 60°C to +160°C

### Materials:

Group I Applications: Brass, Nickel Plated Brass and Stainless Steel

Group II Applications: Brass, Nickel Plated Brass, Stainless Steel and Aluminium

### Certification Details

Adaptor / Reducer Type: 476 (GRP I, II & III)  
 Ex db I Mb, Ex eb I Mb, Ex db IIC Gb, Ex eb IIC Gb, Ex tb IIIC Db  
 Baseefa No: 11ATEX0067X ⓈII 2 GD IP66 CE  
 IECEx No: BAS11.0037X  
 BAS21UKEX0057X UK CA  
 IEx No: 15.0193X  
 EAC TC RU C-GB.AA87.B.00430  
 c CSA us No: 1731876  
 Class I Zone 1 AExd IIC Gb, AExe IIC Gb, Zone 21 AExtb IIIC Db IP66  
 Class I Groups ABCD, Class II Groups EFG, Class III

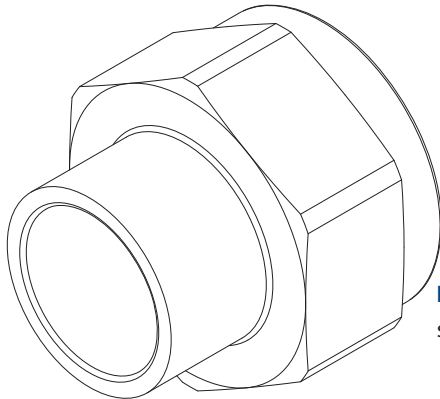

**Fig. 1 - Type 476 Adaptor**  
shown without optional O-Ring

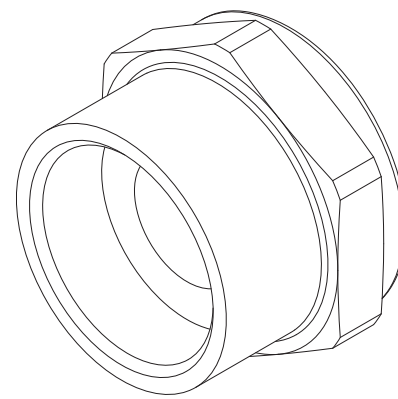

**Fig. 2 - Type 476 Reducer**  
shown without optional O-Ring

**Note:** Only one Adaptor / Reducer shall be used with any enclosure entry. The female thread of an Adaptor must not be more than two sizes greater than the male e.g. M20 to M32.

### SPECIAL CONDITIONS FOR SAFE USE:

1. When the Adaptors or Reducers are used for Increased Safety or Dust Protection without an O-Ring, the entry of the enclosure and the female threads of the Adaptor or Reducer are to be suitably sealed (in accordance with EN 60079-14) to maintain the Ingress Protection rating of the associated enclosure.
2. When the Adaptors or Reducers are used for Increased Safety or Dust Protection in a threaded hole and the O-Ring is fitted, the threaded entry in the enclosure must be at right angles to the enclosure wall, the female threads of the Adaptor or Reducer are to be suitably sealed (in accordance with EN 60079-14) to maintain the Ingress Protection rating of the associated enclosure.
3. When the Adaptors or Reducers are used for Increased Safety or Dust Protection in a plain hole, the hole in the enclosure must be no greater than 0.7mm bigger than the male thread and the Adaptor or Reducer must be secured with a locknut, the female threads of the Adaptor or Reducer are to be suitably sealed (in accordance with IEC 60079-14) to maintain the Ingress Protection rating of the associated enclosure.
4. The Adaptors or Reducers when used in flameproof applications must not be closed with a flameproof stopping plug.
5. Anti-seize spray shall be applied to equipment manufactured from aluminium.
6. The purchaser should make the manufacturer aware of any External effects or Aggressive substances that the equipment may be exposed to.

### STEP 1 (PRIOR TO INSTALLATION)

- Ensure the male thread type and size of the Adaptor / Reducer is compatible with the enclosure thread.
- Where ingress protection above IP54 is required in threaded entries, the use of a suitable non-setting thread sealant or sealing washer is recommended.
- Care should be taken to ensure that any electrical continuity is not affected.

### STEP 2:

Fully tighten Adaptor / Reducer into the enclosure using a wrench / spanner.

### FOR FLAMEPROOF APPLICATIONS:

- With parallel threads, the minimum number of threads engaged must be 5 with an axial engagement of 8mm.
- With taper threaded Adaptors and Reducers the number of threads engaged may be less than 5, but must be greater than 3.5 effective threads engagement.

Declaration of Conformity in accordance with European Directive 2014/34/EU and UK Statutory Instrument 2016/1107

**Manufacturer:** Hawke International, Oxford Street West, Ashton-under-Lyne, OL7 0NA, United Kingdom

**Equipment:** 476 Adaptors and Reducers (Group I & II)

**Provisions of the Directive fulfilled by the Equipment:** Group I Category IM2 Ex db eb I Mb - IP66  
 Group II Category 2GD Ex db eb IIC Gb, Ex tb IIIC Db - IP66

**Harmonized Standards used:** EN 60079-0:2018, EN60079-1:2014, EN60079-7:2015+A1:2018, EN60079-31:2014

**Notified Body for EU-Type Examination:** SGS Fimko 0598 Helsinki Finland

**EU-type Examination Certificate:** Baseefa11ATEX0067X

**Notified Body for production:** 0598

**Approved Body for UK-Type Examination:** SGS Baseefa 1180 Buxton UK

**UK-type Examination Certificate:** BAS21UKEX0057X

**Approved Body for production:** 1180

On behalf of the above named company, I declare that on the date the equipment, accompanied by this declaration, is placed on the market the equipment conforms with all technical and regulatory requirements of the above listed directives.

Andrew Reid  
Technical Manager