

Assembly Instructions for cable gland: 121 Industrial General Purpose

Operating temperature range -60°C +100°C

Certification Details

Gland Type: 121
EN 60529 IP66/67 and IP68 (see AI464)
EN 62444 Certificate of Assessment: CML 15CA932-2

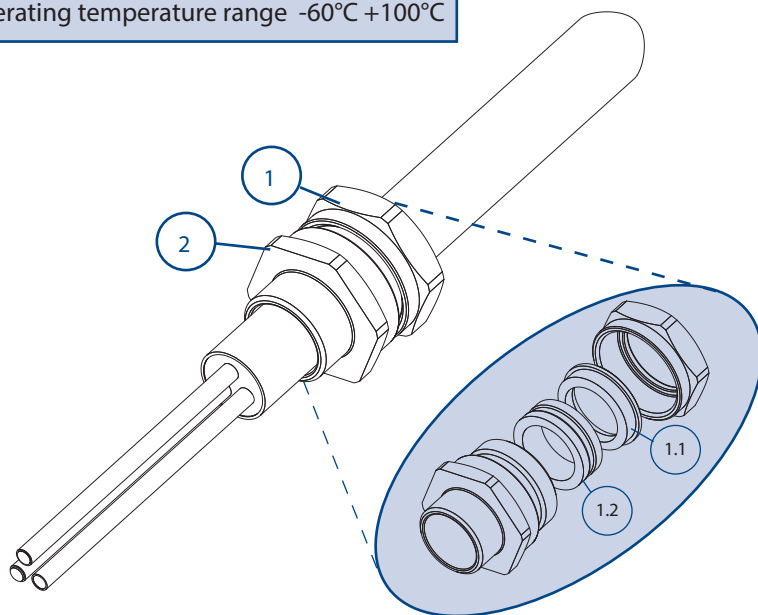

- 1. Backnut
- 1.1 Compression Spigot
- 1.2 Seal
- 2. Entry

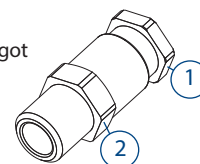

121/2K size only.
View for clarity only,
Do not disassemble ① & ②.

Cable Preparation

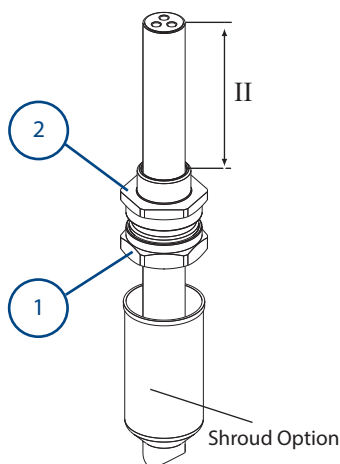

A
Allow sufficient length of cable, II, to suit equipment.
If required, fit shroud.
Pass cable through the cable gland as shown above.

Note: If the equipment has a threaded entry, it may be advisable to screw the cable gland into the equipment to prevent twisting of the cable after Step B

Gland Preparation

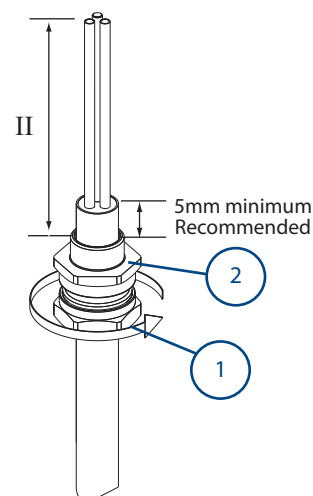

B
Unless already screwed into the equipment, hold the entry ② in position with a spanner/wrench to prevent rotation and tighten the backnut ① using a wrench/spanner until resistance is felt between the seal and cable. Then turn the back nut through a further half to one full turn to complete the inner seal. Locate the shroud over the cable gland, if applicable.

To ease wiring inside the equipment it may be beneficial to strip the outer sheath of the cable as shown above.

IMPORTANT: Support the cable to prevent it from twisting

CABLE GLAND SELECTION TABLE									
Size Ref.	Entry Thread Size		Cable Acceptance Details				Max Length	Hexagon Dimensions	
			Outer Sheath						
	Metric	NPT	Standard Seal		Alternative Seal (S)			Across Flats	Across Corners
			Min.	Max.	Min.	Max.			
2K	M16	---	3.2	8.0	---	---	39	19.0	21.2
Os	M20 ^o	½"	3.2	8.0	---	---	38	24.0	26.5
O	M20 ^o	½"	6.5	11.9	---	---	39	24.0	26.5
A	M20	½" - ¾"	10.0	14.3	9.0	13.5	38	30.0	32.5
B	M25	¾" - 1"	13.0	20.2	9.5	15.4	41	36.0	39.5
C	M32	1" - 1¼"	19.5	26.5	15.4	21.2	43	46.0	50.5
C2	M40	1¼" - 1½"	25.0	32.5	22.0	28.0	44	55.0	60.6
D	M50	1½" - 2"	31.5	42.3/44.4	27.5	34.8	61	65.0	70.8
E	M63	2" - 2½"	42.5	54.3/56.3	39.0	46.5	59	80.0	88.0
F	M75	2½" - 3"	54.5	65.3/68.2	49.5	58.3	60	95.0	104.0
G	M80	3½"	67.0	73.0	---	---	54	106.4	115.0
H	M90	3½"	67.0	77.6	---	---	54	115.0	130.0
J	M100	4"	75.0	91.6	---	---	54	127.0	142.0
K	M110	5"	75.0	91.6	---	---	59	127.0	142.0
L	M120	5"	88.0	104.5	---	---	63	140.0	150.0

- Sizes Os and O are available with an M16 thread size. If M16 entry is used on O Size Cable Glands the maximum cable inner sheath diameter is limited to 10.9mm.

CABLE GLAND CLASSIFICATION																
Cable Gland Type	Material			Mechanical Properties				Electrical Properties				External Influences			Sealing System	
	Metal	Non-Metallic	Composite	Without Cable Anchorage	With Cable Anchorage	Impact Category	Cable Retention (Armoured Cable)	Equipotential Bonding	Connection to Metallic Layers	Protective Connection To Earth	Insulation Characteristics	Ingress Protection	Temperature Range	Resistance to Salt and Sulphur Dioxide Laden Atmospheres	Single Orifice Seal	Multi-Orifice Seal
				Type	Category	Class			Category		IP66 IP67 IP68	-60° To 100°				
121	Y			X	A	8	X	Y	X	X	X	Y	Y	Y	Y	X

INSTALLATION GUIDELINES:

1. Cable gland entry threads are machined in accordance with BS 3643 6g (Metric) or ANSI/ASME B1.20.1 (NPT)
2. The enclosure material shall be compatible with the cable gland.
3. To maintain IP 66/67 ratings, Hawke recommends the use of a Hawke IP Washer or other approved sealing method. To maintain IP68 refer to AI464.
4. To ensure effective sealing of an IP washer, enclosure sealing face surface Finish shall be smooth and free from damage. The entry hole should be Drilled perpendicular to the sealing face.
5. When using enclosures with plain through holes, Hawke recommends Nominal +0.3mm of diametric clearance over the major diameter of the Thread. For example, to accommodate an M20 entry, drill 20.3 diameter.
6. Allowable enclosure wall thickness is dependent on gland entry thread Length, style of enclosure entry hole (threaded or plain), protection concept Of the installation and the required use of accessories. The installer should be Aware of and specify for these requirements.
7. External earth tags are recommended to be fitted adjacent to the range of The cable gland entry, so they remain in direct contact with the cable gland. Any sealing washer should be placed between tag and enclosure. For more Information on placement of accessories, visit www.hubbell.com/hawke.

ACCESSORIES:

Before cable gland assembly or stripping of the cable gland assembly, Consideration should be given to any cable gland accessories that may be required, such as: -

- Shroud, to offer additional corrosion protection.
- Locknut, to secure cable glands into position.
- Sealing washer, to offer additional ingress protection of the enclosure at the cable gland entry.
- Earthtag, to provide an external armour/braid bonding point.
- Serrated washer, to dampen any vibrations that may loosen the locknut or cable gland assembly.

EU Declaration of Conformity in accordance with European Directive 2014/35/EU (from 20th April 2016)

Manufacturer: Hawke International

Address: Oxford Street West, Ashton-under-Lyne, OL7 0NA, United Kingdom.

Equipment Type: 121 Industrial Gland

On behalf of the above named company, I declare that, on the date the equipment accompanied by this declaration is placed on the market, the equipment conforms with all technical and regulatory requirements of the above listed directives.

Standards used: EN 62444 : 2013

.....
A. Reid
Technical Manager