

Operating temperature range -60°C +160°C

Product Materials:

Brass, Nickel Plated Brass and Stainless Steel
(Aluminium Group II Only)
O-Ring: Silicone

Certification Details

Breather Drains Type: 389
Ex eb I Mb / Ex eb IIC Gb / Ex tb IIIC Db
Baseefa11ATEX0153X (Ex) I M2 / II 2 GD IP66 CE
IECEX BAS11.0075X
BAS21UKEX0043X UK
IEEx 15.0208X
ERIC (Ex) No EA3C RU C-GB.HA91.B.00265/21
c CSA us No: 2700364
Class I Zone 1 AExeb IIC Gb, Zone 21 AExtb IIIC Db IP66
(Optional: Class I Div 2 Groups ABCD, Class II Div 2 Groups EFG, Class III)

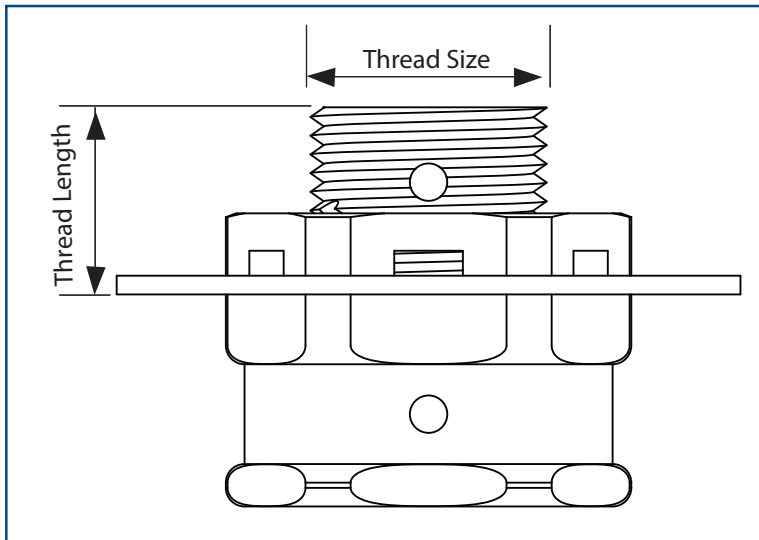

Typical Dimensions

Thread Size Metric	Across Flats	Across Corners	Thread Length
M20	30	32.5	15.0
M25	36	39.5	15.0

NB: Other parallel thread forms are available on request.

SPECIFIC CONDITIONS OF USE:

The breather must be fitted to the bottom face of the enclosure.

For Threaded Entries

1. Ensure the breather drain thread is compatible with the enclosure thread.
2. Ensure that the area around the enclosure entry thread is clean and flat and the entry thread is square to the enclosure face.
3. Insert the breather drains from the outside of the enclosure and fully tighten using the correct size spanner or wrench.

For Clearance Entries

1. If the enclosure contains a clearance hole entry, the maximum clearance permitted between the enclosure entry hole and the breather drain nominal thread size is 0.7mm.
2. Ensure that the area around the enclosure clearance hole is clean and flat.
3. Insert the breather drains into the clearance hole from the outside of the enclosure.
4. Fit the castelated locknut supplied with the breather drain on the thread within the enclosure and tighten fully using suitable spanners or wrenches.

Declaration of Conformity in accordance with European Directive 2014/34/EU and UK Statutory Instrument 2016/1107

Manufacturer: Hawke International, Oxford Street West, Ashton-under-Lyne, OL7 0NA, United Kingdom
Equipment: 389 Breather Drain (Group I & II)
Provisions of the Directive fulfilled by the Equipment: Group I Category IM2 Ex eb I Mb - IP66 (excluding Aluminium)
Group II Category 2GD Ex eb IIC Gb, Ex tb IIIC Db - IP66
Harmonized Standards used: EN 60079-0:2018, EN60079-7:2015+A1:2018, EN60079-31:2014

Notified Body for EU-Type Examination: SGS Fimko 0598 Helsinki Finland
EU-type Examination Certificate: Baseefa11ATEX0153X
Notified Body for production: 0598

Approved Body for UK-Type Examination: SGS Baseefa 1180 Buxton UK
UK-type Examination Certificate: BAS21UKEX0043X
Approved Body for production: 1180

On behalf of the above named company, I declare that on the date the equipment, accompanied by this declaration, is placed on the market the equipment conforms with all technical and regulatory requirements of the above listed directives.

Andrew Reid
Technical Manager

Images are for illustration purposes only.

Product supplied may differ slightly from that shown.