

## FAN KIT CATALOG # HLQFK

## FILTER KIT CATALOG # HLQFF

#8-32 x 3/4" SELF DRILLING  
& TAPPING SCREWS (8)

FAN FILTER

FAN GAURDS

FAN ASSEMBLY

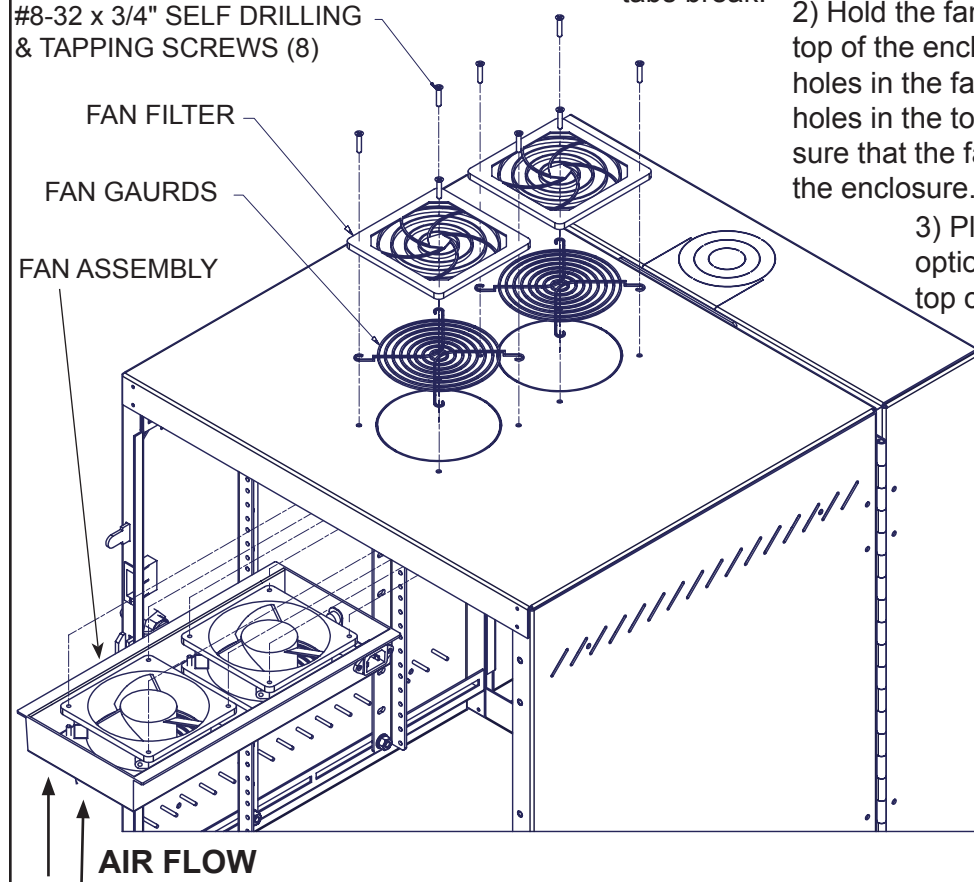

AIR FLOW

1) Remove the two knockouts on the top of cabinet by pushing down on one side and then twisting back and forth until the tabs break.

2) Hold the fan assembly up to the inside of the top of the enclosure so that the mounting holes in the fans match up with the mounting holes in the top of the enclosure. Make sure that the fan cord is toward the rear of the enclosure.

3) Place two fan guards (or fan filters - optional) over the mounting holes in the top of the enclosure.

4) Insert (8) #8-32 x 3/4" long self-tapping screws down through the fan guard, through the top of the enclosure and into the fan assembly.

5) Two fan guards are pre-assembled to the bottom of the fan assembly

1) Protective ground studs are provided along with grounding jumper wires that electrically bond the enclosure doors to the enclosure frame.

**WARNING: To avoid injury to persons or loss of life, ground each enclosure individually to the dedicated branch circuit ground.**

2) Connecting Main Protective Ground Stud to the Dedicated Branch Circuit Ground: Connect the dedicated branch circuit ground connector to the main protective grounding stud located inside on the back of the rear section using a listed ring or closed-loop terminal.

3) Connecting Main Protective Ground Stud to the Protective Bonding Conductors: Connect the middle enclosure frame to the main protective grounding stud located inside on the back of the rear section using a listed ring or closed-loop terminal. If rails need to be bonded to the protective earthing terminal, do so in accordance with Article 250 of the NEC.



Inspect and report any damage before receiving. Unpack the enclosure by carefully removing the corrugated carton and corners.

**CAUTION:** Be careful when moving enclosures before installation. Sudden stops and starts, excessive force, obstructed routes, and uneven floor surfaces may cause the enclosure to topple over. Only install equipment after the enclosure has been properly secured. To maintain a uniform distribution of the mechanical load, load the heaviest equipment first, at the bottom of the enclosure and load the lighter units at the top.

**CAUTION:** Consult all applicable local codes and regulations to determine proper mounting methods. Use of a certified professional engineer is recommended to verify installation.

CATALOG NO.	DOOR TYPE	HEIGHT	WIDTH	DEPTH
HLQ24	WINDOW	24.00"	21.25"	24.50"
HLQ36	WINDOW	36.00"	21.25"	24.50"
HLQ48	WINDOW	48.00"	21.25"	24.50"
HLQ24M	MESH	24.00"	21.25"	24.50"
HLQ36M	MESH	36.00"	21.25"	24.50"

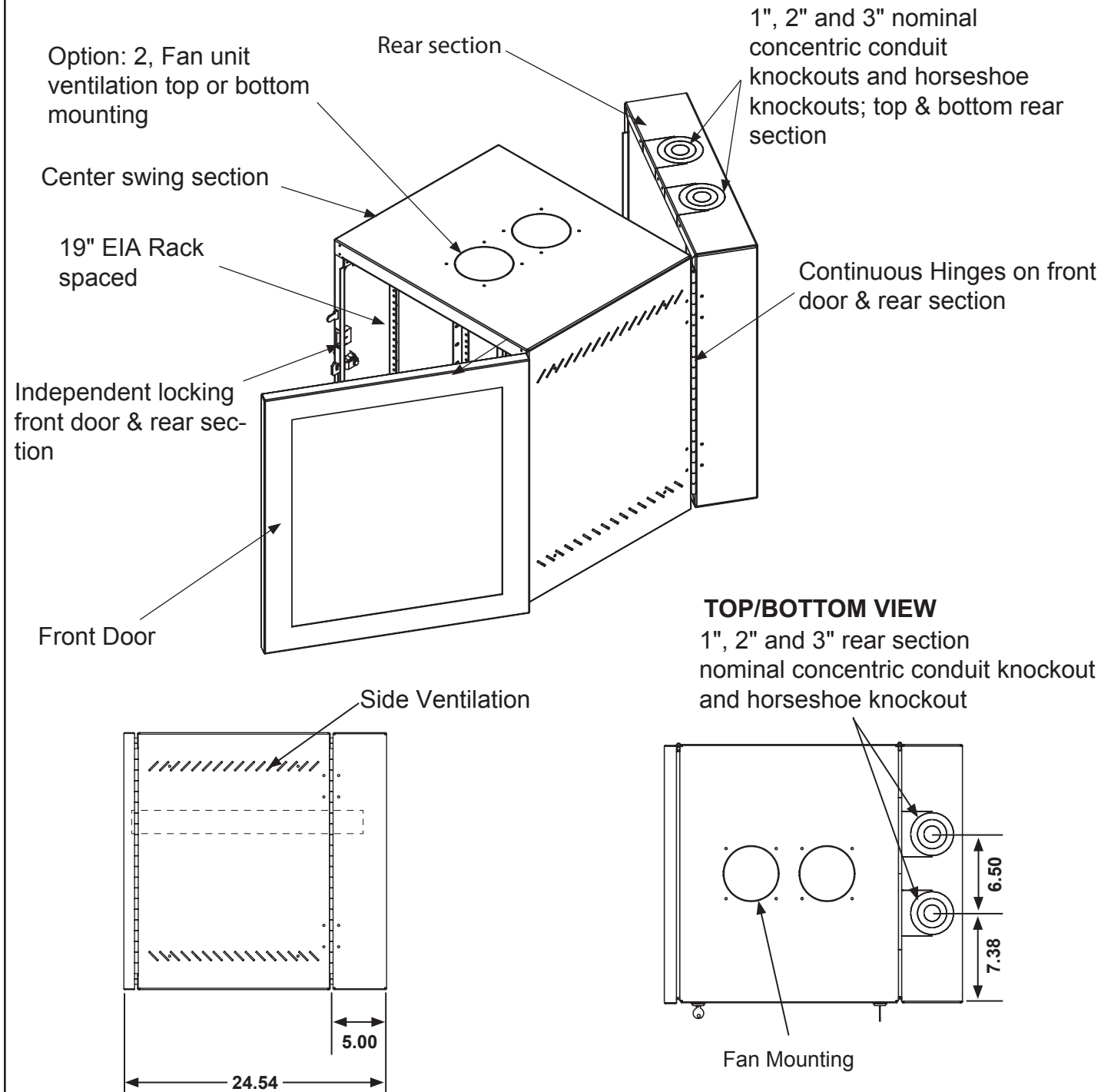

1) MOUNTING TO A WOOD STUDDED WALL

1.1 Use the mounting template to locate your mounting holes.

1.2 The wall must be flat and square in the horizontal and vertical plane to ensure the enclosure closes correctly. If the wall is not flat and square, the use of shims may be required.

1.3 Mounting holes are designed for 3/8" hardware, 16.00" on center for wood studded wall:

Note: Wood studded wall mounting instructions apply to a 2" x 4" wood stud wall with 3/4" plywood. Recommended hardware is (4) 3/8 x 2" long lag bolts and (4) 1" O.D. flat washers (hardware not included)

For masonry wall surface, the installer is responsible for specifying all of the appropriate hardware.

**DO NOT USE DRYWALL SCREWS OR TOGGLE BOLTS!**

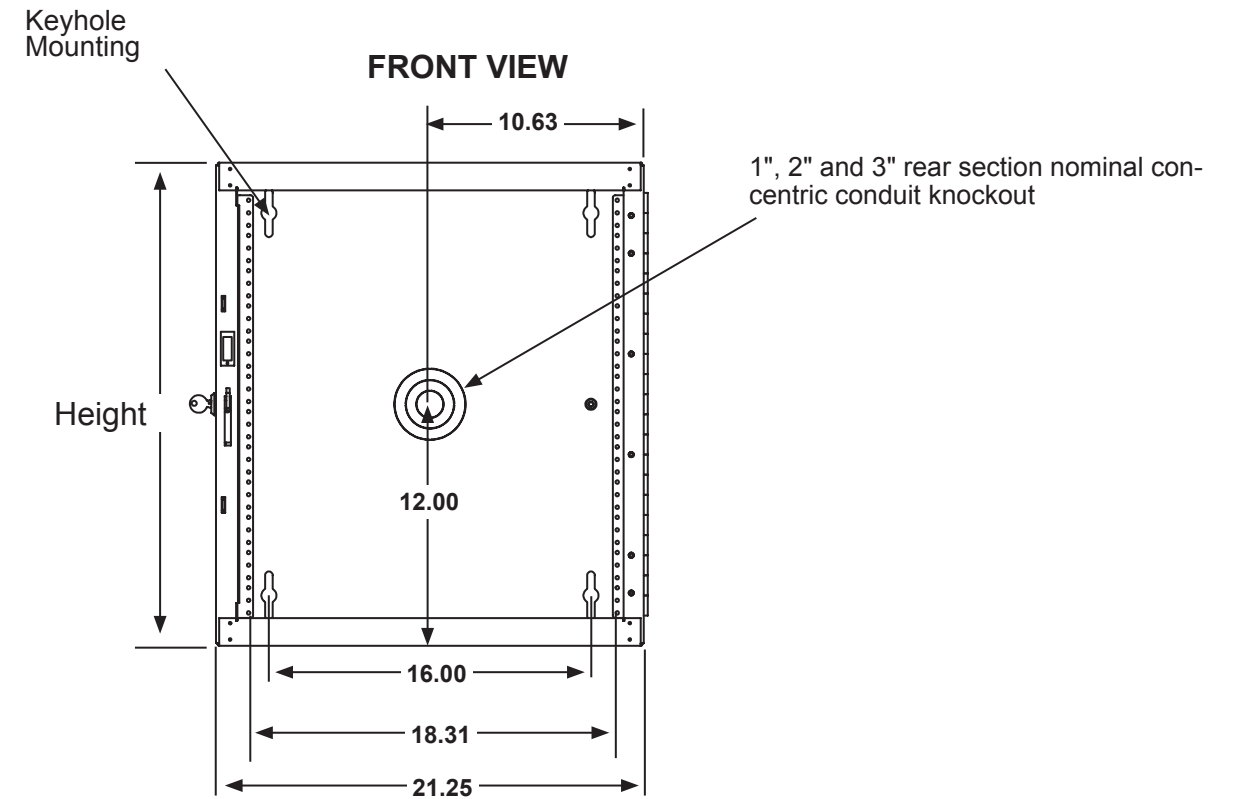

**WARNING:** Only install equipment after the enclosure has been properly secured. Do not move the enclosure assembly while loaded.