

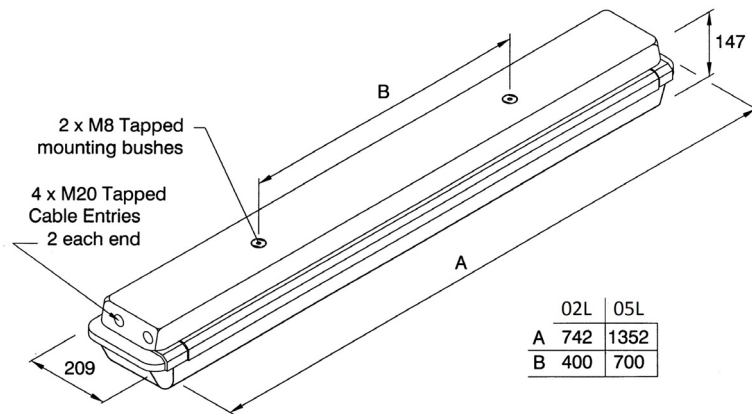

INSTALLATION, OPERATION AND MAINTENANCE INSTRUCTIONS

Protecta III - LED GRP

Important: Please read the following instructions carefully prior to installation or maintenance of this equipment.



| | |
|----------------------|--|
| Types of protection | Ex e mb q Increased safety, Encapsulation, Powder filling Ex d e mb q (with Ex d switch). |
| Protection Standards | ABNT NBR IEC 60079-0, 60079-1, 60079-5, 60079-7, 60079-18, 60079-28. |
| Area of application | Zone 1 and Zone 2 areas to (ABNT NBR IEC 60079-10)3 |
| Installation | ABNT NBR IEC 60079-14 |
| Certificate | IEEx 13.0220 |
| Equipment coding | Ex eb mb q IIC T4 Gb or Ex db eb mb q IIC T4 Gb Ex eb mb op is q IIC T4 Gb or Ex db eb mb op is q IIC T4 Gb |
| Ambient range | -40°C ≤ Ta ≤ +55°C. |
| Ingress Protection | IP66/67 |



1.0 Introduction – Protecta LED GRP

This installation leaflet covers the range of Protecta GRP luminaire models with the Ex q control gear. These luminaires are mainly used in harsh environments and are constructed using a corrosion resistant glass reinforced polyester body and polycarbonate diffuser. Refer to the current catalogue for information on product references. The luminaires are available in 02L (2ft) and 05L (4ft) sizes.

2.0 Electrical Supplies

| Lamps | 02L - 2 x 600mm LED Strip | 05L - 2 x 1200mm LED Strip |
|-----------------------|---------------------------|----------------------------|
| Voltage range AC | 110-130V or 220-254V | |
| Frequency range Hz | 47-63Hz | |
| Power Watts 220-254V | 32W | 62W |
| Current Amps 220-254V | 0.16A | 0.30A |
| Power Watts 110-130V | 32W | 62W |
| Current Amps 110-130V | 0.28A | 0.55A |

The safety limit for surface temperature (T rating) is +/-10% on the rated voltage. The maximum nominal variation from rated voltages stated above is +/- 6%.

Power Factor >0.95

Power is constant over voltage range.

Over Voltage

400V ac for 1 min and EN 61000-4-5 > 4kV

Through Wiring

The through current rating is 16A. 4mm² terminals are standard (6mm² wiring can be used in the terminals in accordance with the luminaire certificate).

Fuse and MCB Ratings

It is recommended that for selection of MCBs users should consult the MCB manufacturer as this unit contains electronic control gear. The electronic control gear has nominal values of inrush current of 35A for 70µs on 230V and 70A for 70µs on 110V.

Storage

Luminaires are to be stored in cool dry conditions preventing ingress of moisture and condensation. Storage temperature range to be -40°C to +80°C.



Typical wiring diagram shown for information only, some models may differ.

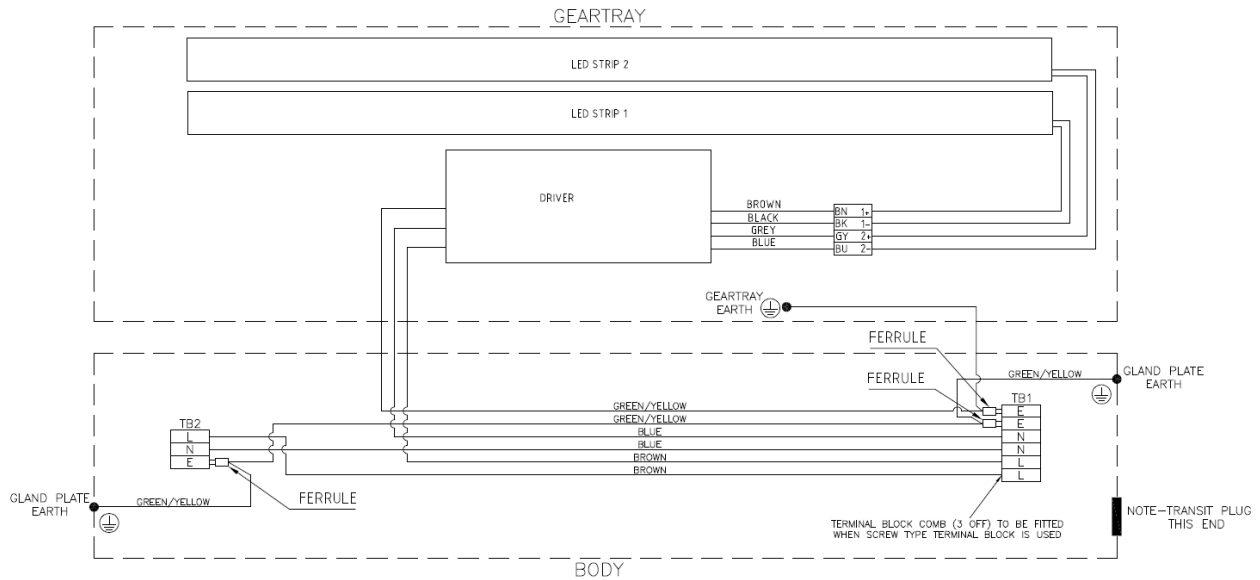

3.1 General

These instructions should be read fully and carefully before attempting to install the luminaire. For details of servicing operations, opening etc. see section 4.0.

Copies of these instructions should be held in a safe place for future reference. It is the responsibility of the installer to ensure that the apparatus selected is fit for its intended purpose and that the installation, operation and maintenance of the apparatus complies with applicable regulations, standards or codes of practice. Installation should be carried out in accordance with ABNT NBR IEC 60079-14 or with a local hazardous area code of practice, whichever is appropriate.

Risk of electrostatic discharge:

- Clean diffuser only with damp cloth
- Avoid mounting near fast moving streams of air

Any specific installation instructions must be referred to. In the UK the requirements of the *Health and Safety at Work Act* must be met and electrical work associated with this product must be in accordance with the *"Manual Handling Operations Regulations"* and *"Electricity at Works Regulations 1989"*. Disposal instructions should be complied with. The luminaires should be considered Class 1 to EN 60598 and effectively earthed. Certification details on the rating plate must be verified against the application requirements before installation. The information in this leaflet is correct at the time of publication. The company reserves the right to make specification changes as required without notice.

3.2 Tools

3mm and 4mm flat blade screwdriver and large crosshead screwdriver. Suitable spanners for installing cable glands. Pliers, knife, wire strippers/cutters.

3.3 Mounting

Luminaires should be installed where access for maintenance is practical and in accordance with lighting design information. For horizontal mounting on handrails Chalmit recommend mounting the luminaire with the clamp bar uppermost therefore allowing the diffuser and gear tray to swing down when necessary. Refer to the note in 3.1 concerning electrostatic charge. The standard suspension is via two M8 x 12mm deep blind tapped holes in stainless steel bushes in the top of the body, the recommended torque for the fixing bolts is 10-15Nm. Various adaptors, pole clamps and suspension brackets are available to order.

3.4 Cabling and Cable Glands

The temperature conditions at the supply cable entry point are such that 70°C (ordinary PVC) cable can be used. Equipment certified cable glands and sealing plugs must have suitable "Geração E" approval. When installed the cable gland or sealing plug should maintain the IP rating of the enclosure, IP66/67.



Four entries are provided. Three entries are fitted with suitably approved blanking plugs, the fourth entry with a transit plug. M20 x 1.5 entries are standard, other sizes are available on request. The standard entry configuration is with an earthed metal plate with tapped holes mounted in the body.

3.5 Electrical Connections and Testing

If any work is to be done on any luminaire already connected to the electrical system, the luminaire must be isolated from the system. The diffuser cover is swung down and removed, if necessary, by swivelling back as far as possible then lifting off. To access the mains terminals loosen the four fixing screws, slide the reflector/gear tray over the slots and swing the reflector/gear tray down. Luminaires are supplied suitable for looping and through wiring. Screw type or screw-less "cage clamp" terminals are fitted in the range of luminaires. Mains terminal blocks are marked L N Earth.

The maximum amount of insulation allowed beyond the throat of the terminal is 1mm. The normal method of insulation testing is to connect Live and Neutral together and test between this point and Earth to prevent the risk of damage to the electronic control gear. However, if this is not possible luminaires can be tested with an insulation tester that complies with IEC 364 or BS 7671 with a maximum output current of 1mA and output voltage of 500V dc. (Units damaged by incorrect insulation testing can be detected). Before completing the wiring, ensure that all the connections are correctly introduced into place before reassembling the luminaire.

4.0 Servicing and Operation

Safe servicing behind the gear tray requires the mains supply to be isolated.

4.1 Opening and Closing the Cover

Insert a screwdriver into one of the slots in the clamping bar with the end of the tool located into the outer flange of the body as a fulcrum point, a wide blade screwdriver is recommended. Gently lever the tool away from the diffuser, the clamping bar will begin to open. Insert the tool in the other clamping bar slot and gently lever away from the diffuser, the clamping bar will open and the cover will be retained by the hinge. Should difficulty be experienced reinsert the tool in the first slot and repeat the procedure.

The procedure for closing and securing the cover is as follows:

Ensure the hinge mechanism is clear of any obstruction and then swing the diffuser into the closed position. Support the diffuser in position whilst pushing the clamp bar over the edge of the diffuser. Apply even pressure at both ends of the bar and press the bar over centre making sure that it goes fully into position.

To remove and replace the diffuser open the diffuser to 180° and it will lift out. When replacing ensure that all the hinges are into place before attempting to close.

4.2 Removal and Replacement of Clamping Bar (if required)

Open the luminaire as above and remove the diffuser or let it swing down. Press the clamping bar towards the closed position, tip forward beyond the closed position and the clamping bar will be released from the body. To replace the clamping bar, put in position on the body with the front edge pointing as far inwards as it will go. Click the bar outwards and bring back to the normal closed position. The clamping bar should then be secured in position, open the clamping bar fully by using hand or screwdriver pressure (avoid damaging the gasket), the clamping bar is then ready to accept the normal closure of the diffuser.

4.3 Releasing the Gear Tray

Loosen the four fixing screws retaining the gear tray far enough for it to slide over keyhole slots. The tray will hang on the retaining cords without stressing the wiring between body and tray. Replace in reverse order.

4.4 Removal of Gear Tray

Release gear tray from body and hang on retaining cords, as explained above. Disconnect the cables from the gear tray to the mains terminal block, unhook retaining cord from gear tray and lift clear. With disconnection made at the screw-less terminals the luminaire is safe when re-closed without the tray.

4.5 Servicing Behind the Gear Tray

The release of the gear tray exposes live mains terminals. Any work behind the gear tray requires that the supply is isolated to avoid ignition risk and damage to components.

4.6 Replacement of LED Strips

Remove gear tray from the body and swing down as previously explained. Identify the wires for the LED strip/s and disconnect from the terminal block. Remove screws and clips holding the strips in place. Replace strips using screws and clips and reconnect to terminal block. Check connections before re-energising.

4.7 Replacement of Driver

The driver contains no serviceable parts. Should it be found necessary to replace the driver, the following procedure should be adopted: Ensure that the luminaire is isolated from the mains supply.



Remove gear tray from body and swing down as previously explained. Disconnect the driver wires from the terminal blocks (note the connections) and

remove the driver from the tray.

5.0 Routine Maintenance

Visual tests and checks should be carried out at intervals described by the appropriate regulations, EN 60079-17, and should include the following:

- Check for mechanical damage/corrosion.
- Check connections, fixings, glands and plugs.
- Check for undue accumulations of dust, dirt or moisture.
- Check for unauthorised modifications.

Periodic inspection of the enclosure seal should be carried out to ensure that the seal is sound. The seal can be replaced and, if necessary, secured in position by the application of a **very** small amount of rubber adhesive and using the joining piece. Care must be taken to ensure seal is not stretched during assembly. If the luminaire has been subject to abnormal conditions, for example, severe mechanical impact or chemical spillage, it must be de-energised until it has been inspected by an authorised and competent person

5.1 Cleaning

The body of the luminaire may be cleaned with a mild solution of household detergent and water, after cleaning the body should be washed and wiped with clean water. **The diffuser should not be polished or wiped with a dry cloth as a risk of ignition due to electrostatic discharge may result.** Cleaning of the diffuser with any chemical or hydrocarbon solvent based cleaner may result in severe damage.

6.0 Disposal of Material

Disposal of the luminaire as waste should be carried out in accordance with national regulations. Any disposal must satisfy the requirements of the WEEE directive [2012/19/EU] and therefore must not be treated as commercial waste. The unit is mainly made from incombustible materials. The control gear contains plastic, resin and electronic components. All electrical components may give off noxious fumes if incinerated.

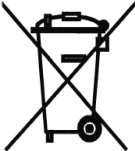

To comply with the Waste Electrical and Electronic Equipment directive 2012/19/EU the apparatus cannot be classified as commercial waste and as such must be disposed of or recycled in such a manner as to reduce the environmental impact.

Chalmit Lighting is a leading supplier of Hazardous Area lighting products

| | | |
|---|--|--|
| | CHALMIT LIGHTING PO Box 5575 Glasgow, G52 9AP Scotland | |
| Telephone: +44 (0) 141 882 5555 Fax: +44 (0) 141 883 3704 Email: info@chalmit.com Web: www.chalmit.com | Registered No: 669157 Registered Office: Cannon Place 78 Cannon Street London EC4N 6AF UK | |

For technical support, please contact: techsupport@chalmit.com

Note: Chalmit Lighting reserves the right to amend characteristics of our products and all data is for guidance only.