

STEP 6 – INSTALLATION – JUNCTIONS WITH U-STRAPS

Step 1 – Determine Location

Identify location for the junction assembly. Mark the location for the junction assembly using the U-strap holes as a template.

Step 2 – Mount Deadbreak Junction

Attach deadbreak junction to a flat metallic surface* using the U-strap(s) provided. Use 5/16" diameter screws and 5/16" split lock washers. Tighten securely to prevent movement during operation.

Important: The base of the deadbreak junction conductive jacket must be grounded via contact with the conductive mounting surface.

STEP 7 – OPERATING INSTRUCTIONS

Remove all protective shipping caps and wipe the operating interfaces clean. Lubricate each interface with the supplied lubricant or an approved equivalent. **DO NOT SUBSTITUTE.** Other lubricants may be harmful to this product or a mating connector.

Install the mating products following the instructions supplied with the mating product.

NOTES:

If a position is not to be used, cap it off with an approved insulating cap. Do not use the protective shipping caps for this purpose as they are only intended to keep the interfaces clean during shipping and handling.

DO NOT energize or submerge the apparatus with the shipping caps installed.

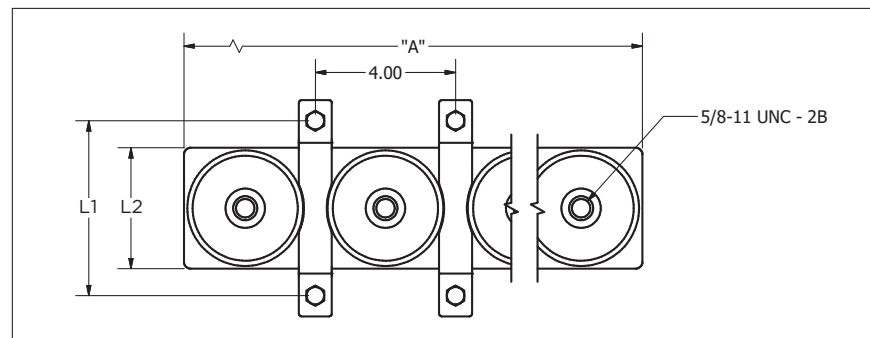

Figure 6

Number of Positions	Spacing	Catalog No.	A	L1	L2
2	4"	635J2U	7.50"	5.00"	3.46"
	6"	635J2XLU	9.00"	4.63"	3.00"
3	4"	635J3U	11.50"	5.00"	3.46"
	6"	635J3XLU	15.00"	4.63"	3.00"
4	4"	635J4U	15.50"	5.00"	3.46"
	6"	635J4XLU	21.00"	4.63"	3.00"



IS635JCT

Installation & Operating Instructions



35kV 600 A Junctions

DESCRIPTION

Hubbell 600 A junctions are designed and tested to meet all requirements of IEEE Std. 386. When mated with appropriate accessories, they can create taps, loops, and splices in URD systems and are fully shielded and submersible. They are typically installed in vaults or sectionalizing cabinets and are available in three and four position versions.

35kV class: 21.1kV



CONTENTS OF PACKAGE

- (1) Multi-Point Junction
- (1) SS Bracket and Mounting or U-straps
- (1) Installation Instructions
- (1) Lubricant – one per interface

DO NOT SUBSTITUTE

INSTALLATION TOOLS

- Hand tools

Important: Read these instructions thoroughly before operating the system. Be sure that the connectors are rated for the intended energized use. Visually inspect parts for damage before using.

CAUTION

The equipment covered by these instructions should be installed, operated and serviced only by competent personnel trained in good safety practices. This instruction is written for such personnel and is not intended as a substitute for adequate training and experience in safe procedures for this type of equipment.

DANGER

All apparatus must be de-energized during installation or removal of parts. Do not touch or move energized product by hand. Failure to follow this instruction may result in serious or fatal injury, as well as damage to the product.

DANGER

Remove all protective shipping caps and replace with an approved insulating cap or connector prior to the junction being submersed or the circuit energized. The protective shipping caps are intended to keep the interfaces clean during shipping and handling and should never be used on energized equipment.

These instructions do not purport to cover all details or variations in equipment nor to provide for every possible contingency to be met in connection with installation, operation or maintenance. Should further information be desired or should particular problems arise which are not covered sufficiently for the purchaser's purposes, the matter should be referred to Hubbell Power Systems, Inc.

INSTALLATION - JUNCTIONS WITH BRACKETS

Step 1 - Attach Bracket Feet

Loosely attach bracket mounting feet to the adjustable mounting brackets using supplied 5/16" hardware. See Figure 1.

NOTE:

Bracket mounting feet can be aligned to face either the inside or outside direction based on the location and spacing of the mounting holes on the wall.

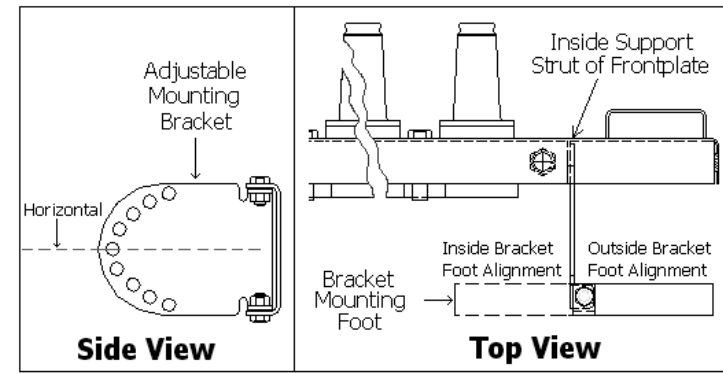

Figure 1

Step 2 - Attach Adjustable Brackets

Align junction frontplate with adjustable mounting brackets ensuring that the desired angle has been obtained. Securely attach bolts once the proper mounting angle has been achieved. See Figure 2.

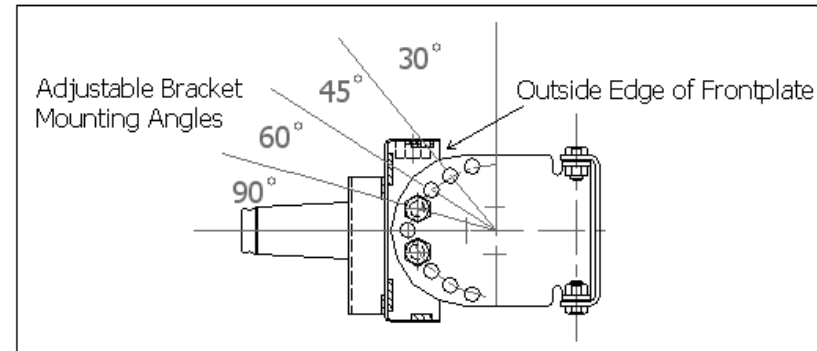

Figure 2

Step 3 - Mounting Dimensions

Refer to Figure 3 and Table 1 for mounting dimensions.

NOTE:

Adjustable mounting brackets can be attached with the feet pointing out or in.

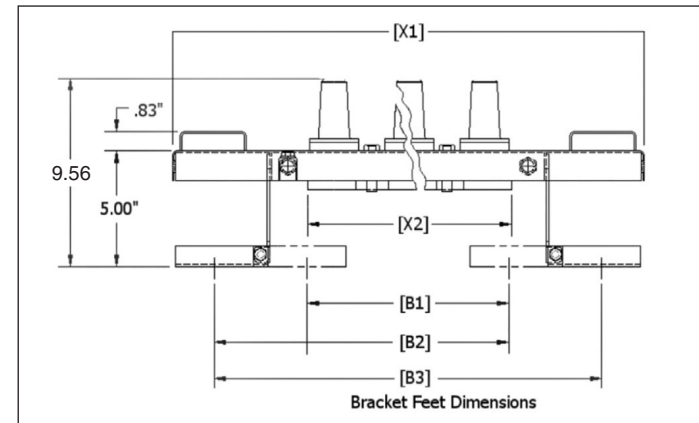

Figure 3

Number of Positions	Spacing	Catalog No.	X1	X2	B1	B2	B3
2	4"	635J2B	15.10"	7.50"	3.40" - 8.40"	7.90" - 13.30"	12.80" - 17.80"
	6"	635J2XLB	17.08"	9.00"	5.40" - 10.40"	9.90" - 15.70"	15.20" - 20.20"
3	4"	635J3B	23.00"	11.50"	7.50" - 12.50"	12.00" - 17.00"	16.50" - 21.50"
	6"	635J3XLB	26.00"	15.00"	11.40" - 16.40"	15.90" - 21.70"	21.20" - 26.20"
4	4"	635J4B	27.00"	15.50"	11.50" - 16.50"	16.00" - 21.00"	20.50" - 25.50"
	6"	635J4XLB	32.00"	21.00"	17.40" - 22.40"	16.90" - 27.70"	27.20" - 32.20"

Step 4 - Tighten and Ground

Locate the full junction assembly to the final position, mark the attachment locations on the mounting surface, and tighten the bracket mounting feet hardware in this final position. Drill holes at the marked locations if required, and securely attach the full junction assembly to the mounting surface using customer supplied hardware. See Figure 4.

NOTE:

Bracket and Clearance Spacing based on feed-thrus in the parking stands. (See Fig.4) Allow sufficient space for elbow operation.

CLEARANCE REQUIREMENTS:

- Vault Wall (Dimension A) or Enclosure (Dimension B)
- 35kV = 3.25"

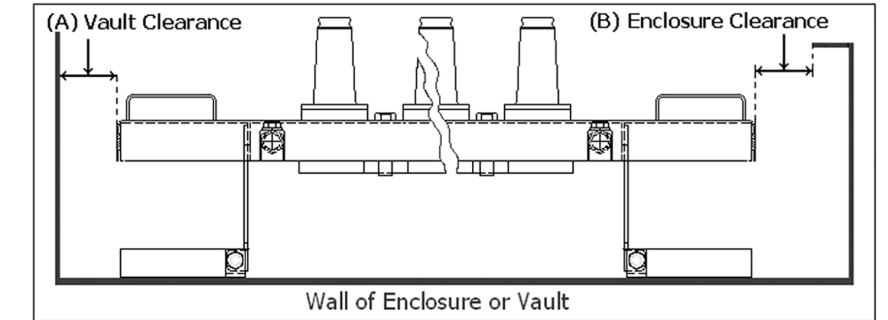

Figure 4

Step 5 - Tighten and Ground

Securely tighten all connections from previous assembly steps and assemble ground clamp to either of the connection points provided on the front plate. Connect the bracket to system ground with the grounding clamp. See Figure 5.

NOTE:

Ground clamp can accommodate wire sizes of #6 to 1/0 stranded.

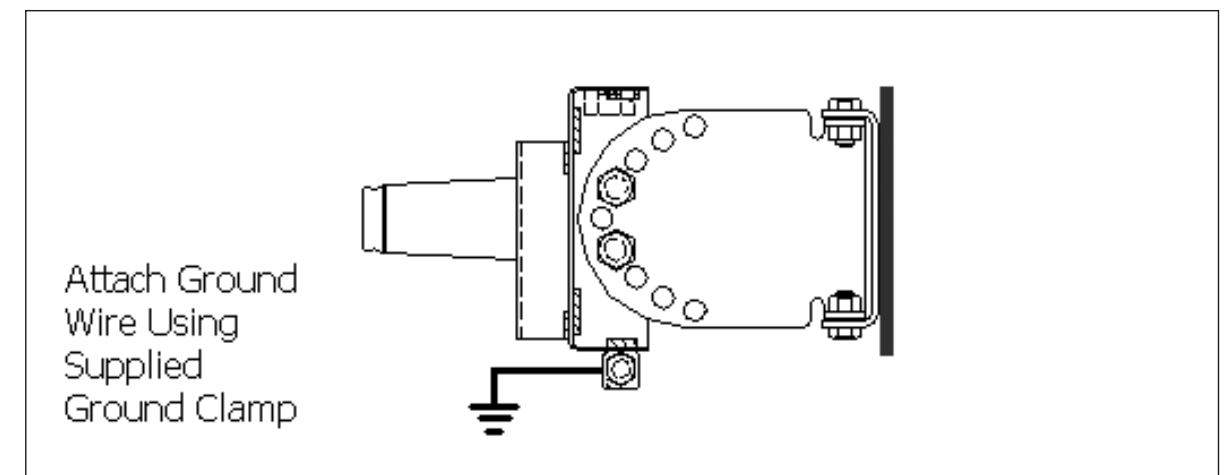

Figure 5

WARNING

Failure to properly ground the 600 A junction may lead to the presence of hazardous voltage, which can result in serious injury or death.