



# INSTALLATION, OPERATION & MAINTENANCE DATA SHEET

## “EBS” SERIES EMERGENCY BATTERY OPERATED FACTORY-SEALED LIGHTING SYSTEM

READ THIS SHEET CAREFULLY BEFORE BEGINNING INSTALLATION.

**CAUTION:** Before installing, make sure you are compliant with area classifications, failure to do so may result in bodily injury, death and property damage. Do not attempt installation until you are familiar with the following procedures. All installation must comply with the applicable Electrical Code.

Make sure that the circuit is De-energized before starting installation or maintenance.

Verify that the installation is grounded. Failure to ground will create electrical shock hazards, which can cause serious injury and or death.

**Important:** Please read these instructions carefully before installing or maintaining this equipment. Good electrical practices should be followed at all times and this data should be used as a guide only.

## Application

The EBS (Emergency Battery System) is an emergency battery LED lighting system for use in hazardous locations. It is designed to automatically provide illumination to designated areas during failure or interruption of power to the normal lighting system. The EBS system consists of a main battery unit and two of the following luminaires: an EBSL1030 luminaire head and/or an EBSHK1030 luminaire head. The EBSEL1030 is an LED down light with an optional EXIT sign attachment, while the EBSHK1030 is an LED spotlight luminaire.

The EBS system main unit consists of an emergency battery supply and a battery charging / recharging system, housed inside a hazardous area enclosure, with circuitry that automatically turns on emergency DC LED lighting fixtures when normal power fails. A pilot light indicates when normal power is present at the system. A push-to-test switch is provided as either an integral system or a remote option, and is provided for periodic testing of the unit.

1. Do not use this equipment for other than the intended use as specified on the equipment nameplate.
2. Turn **OFF** the supplying circuit before beginning installation or performing any maintenance, including re-lamping **with power turned off, service must be done in non-hazardous**

**WARNING:** The EBS23 System Requires EXACTLY two or four heads for operation (total attached or remote). Each head is approximately 30VDC, 10W (two heads) and 5W (four heads). See wiring diagrams 7 and 8.

## Notes

Main EBS unit is C1D1 Group B (Suitable Zone 1 IIB+H2) with attached EBSHK heads or no heads; with attached EBSEL heads unit is C1D1 Groups CD (Suitable Zone 1 IIB, IIA)

**Class I, Div. 1&2, Groups B,C,D**

**Class I, Zone 1&2, Groups IIB+H2, IIA**

**Class II, Div. 1&2, Groups EFG**

**Class III**

**Enclosure Type 4 (NEMA 4, 7B CD,9EFG)**

**atmosphere.** Service should be performed by qualified service personnel.

3. Do not mount near gas or electric heaters.
4. Do not attempt to service the batteries; they are maintenance free. Once a year, conduct a 90-minute discharge test. The emergency LED load should operate for a minimum of 90 minutes on battery power. Then, restore AC power. This puts the battery through a discharge/recharge cycle over its full intended range, and also provides a rigorous test of overall unit operation.
5. Batteries must be recycled or disposed of properly.
6. Equipment should be mounted in locations and at heights where it will not readily be subjected to tampering by un-authorized personnel.
7. The use of accessory equipment not recommended by the manufacturer, as it may cause an unsafe condition.
8. See unit nameplate for specific hazardous location suitability and specific supply wire (minimum temperature rating). Do not operate this unit if the ambient temperature exceeds the rating shown.
9. All conduit fittings must be engaged at least 5 full NPT threads.
10. **WARNING:** Do not operate this unit on an ungrounded system. Failure to ground will create electrical shock hazards, which can cause serious injury and/or death.

EBS23DH Electrical Data						
Catalog Number	Input **			Output **		
	Voltage	Watts	Current	Voltage	Watts	Current
EBS23DH	120-277VAC	7.5	.1	33VDC	23	700mA

\*\* Figures nominal. Current is 350mA to each of the two heads.  
 (Two heads are required for proper operation, remote or attached).

Thermal Performance Data					
Catalog Number	Ambient	C1D1	C2D1	Suitability	Supply Wire
EBS23DH	45°C	T6	EFG	0-45°C	75°C
EBSEL1030	55°C	T6	EFG	-40°C to 40°C	75°C
EBSHK1030	55°C	T6	EFG	-40°C to 40°C	75°C

## Installation

Select a mounting location that will provide suitable strength and rigidity for supporting the EBS Main Unit and attached LED luminaires (if applicable). The recommended mounting position is with the back wall of the enclosure attached to a vertical surface with the pilot light located on the bottom of the enclosure.

The battery enclosure is intended for surface mounting using the holes provided in the two mounting flanges. Fasten the battery enclosure to mounting location using 3/8" diameter bolts, screws, or applicable mounting hardware.

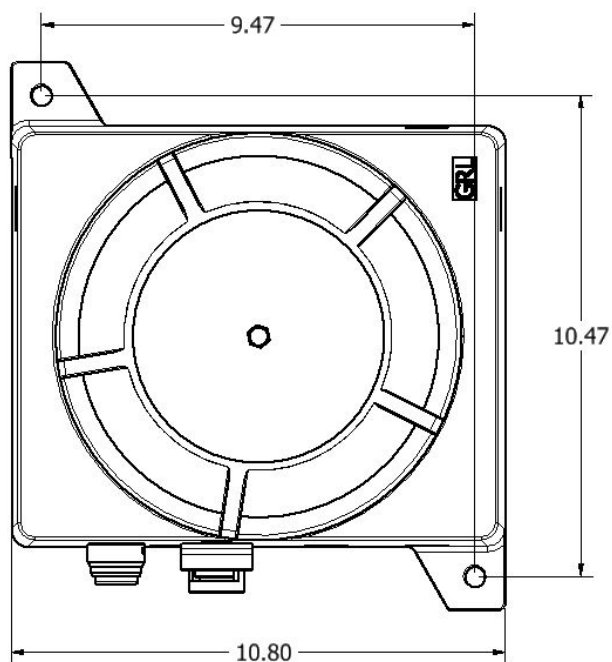

**EBS Main Unit  
 Mounting Dimensions  
 (Front)**

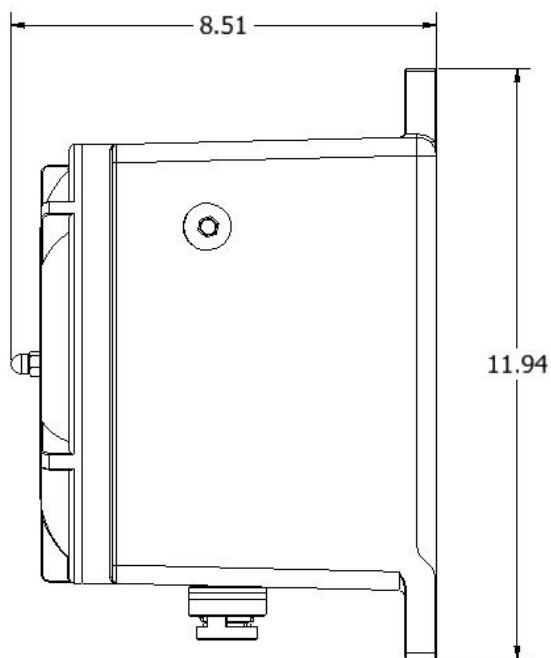

**(Side View)**

**WARNING:** A Class I, Division 1 sealing fitting is required to be installed within 18 inches of any conduit entry into the EBSDH23 main unit enclosure and within 18 inches of EBSHK1030 LED Luminaire fixture when installed remotely. See Figure 5 for details.

# Luminaire Configurations

## 1. Factory installed EBSHK1030 Heads (Figure 1)

EBS Systems ordered with (2) EBSHK1030 heads factory installed contain conduit unions, right angle conduit unions, and **Factory Sealed Potted Nipples**. Since the potted nipples (**Figure 2**) serve as a sealing fitting, additional fittings are not required. To adjust angle of EBSHK1030 head use the following:

### Horizontal Direction

Loosen Nut "A" with a strap wrench (or appropriate alternative). Adjust luminaire head to desired alignment, and re-tighten to 45ft-lbs. torque. See **Figure 2** for more details. **Note:** Killark "LUBT" lubricant must be applied to all straight threads on unions in order to maintain NEMA 4 rating.

### Vertical Direction

Loosen Nut "B" with a strap wrench (or appropriate alternative). Adjust luminaire head to desired rotational position, and re-tighten to 45 ft-lbs. torque. See **Figure 2** for more details. **Note:** Killark "LUBT" lubricant must be applied to all straight threads on unions in order to maintain NEMA 4 rating.

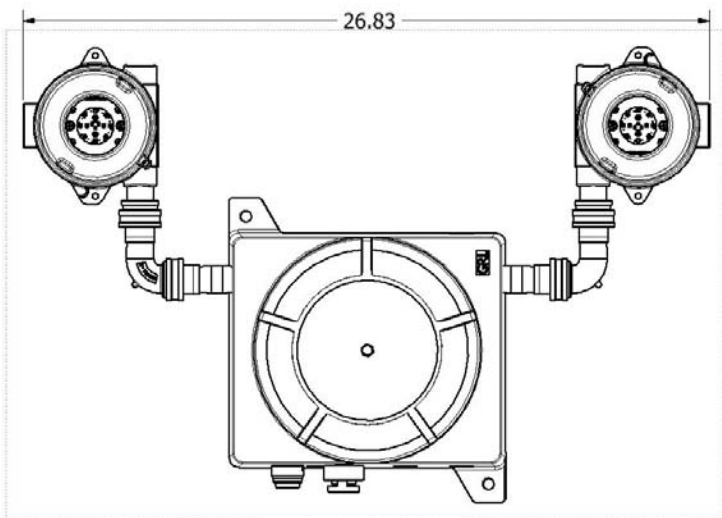

(Figure 1)

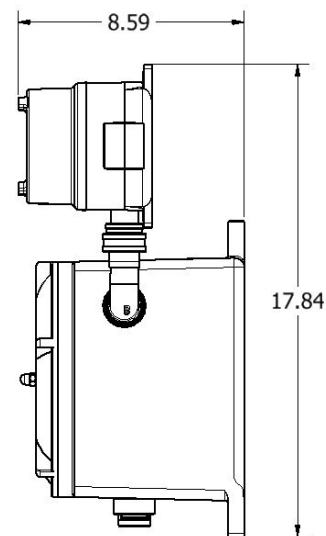

**CAUTION:** EBSHK10350 luminaire head is limited to no more than 180° of rotational adjustment. Failure to do this will result in damage to internal wiring.

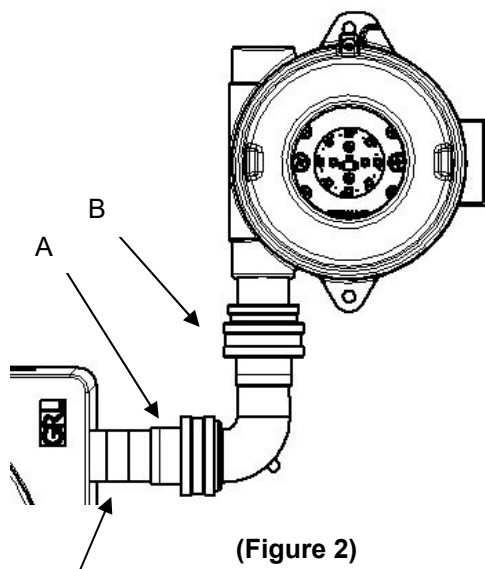

(Figure 2)

(Factory Sealed)

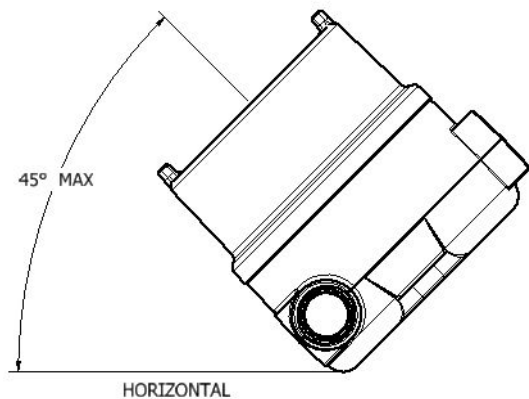

**CAUTION:** Class I, Class II and Class III locations. Limit upward aiming of HK fixture to a maximum of 45° above horizontal. Greater upward aiming could lead to excessive dust buildup and dangerous overheating.

## 2. Factory installed EBSHK1030 (1) & EBSEL1030 (1)

EBS Systems ordered with (1) EBSHK1030 head and (1) EBSEL1030 head will come with the EBSHK1030 preassembled to the battery enclosure, while the EBSEL1030 and applicable unions and fittings (EBS-AHFS) will ship in a separate package (which will include unions and a **Factory Sealed Potted Nipple** for direct attachment to the battery enclosure).

To adjust angle of EBSHK1030 head, refer to **Luminaire Configuration 1** for procedure.

To install EBSEL1030 head, assemble fittings onto potted nipple as seen in **Figure 3**. Pull black and white wire from potted nipple through conduit union assembly, and wire to terminal block in included "EZA2" pendant mount splice box, attaching the black wire to the "Line" terminal and the white wire to the "Neutral" terminal. Thread the EZA2 splice box onto the downward facing union a minimum of five threads. Loosen the locking screw 'A' on the pendant mount. Make sure the external threads at the top of the EBSEL tank are free of any dirt, metal chips or other foreign materials. Apply a thin coat of Killark "LUBT" lubricant to the threads. Thread the EBSEL fixture into the pendant mount. See **Figure 3** for more details.

### Note

Take extreme care not to cross-thread the unit when installing into the mounting accessory; the electrical contacts will automatically engage. Be sure the unit is threaded tight. Tighten the set screw 'B' on the side of the mounting accessory.

To adjust the angle of EBSEL1030 head, orient luminaire with globe down and tighten unions to the following:

#### Horizontal Direction

Loosen Nut "C" with a strap wrench (or appropriate alternative). Adjust luminaire head to desired alignment, and re-tighten to 45 ft-lbs. torque. See **Figure 3** for more details. **Note:** Killark "LUBT" lubricant must be applied to all straight threads on unions in order to maintain NEMA 4 rating.

#### Vertical Direction

Loosen Nut "D" with a strap wrench (or appropriate alternative). Adjust luminaire head to desired rotational position, and re-tighten to 45 ft-lbs. torque. See **Figure 3** for more details. **Note:** Killark "LUBT" lubricant must be applied to all straight threads on unions in order to maintain NEMA 4 rating.

## 3. Units with (2) EBSEL1030 Heads (Not Shown)

EBS Systems ordered with (2) EBSEL1030 heads (for direct attachment) will come with each EBSEL1030 and applicable unions and fittings (EBS-AHFS) in a separate package.

To install EBSEL1030 heads, follow **Luminaire Configuration 2** for instructions.

## 4. Units with Remote EBSEL1030 or EBSHK1030-RFSC / EBSHK1030-RFSL Heads (Not Shown)

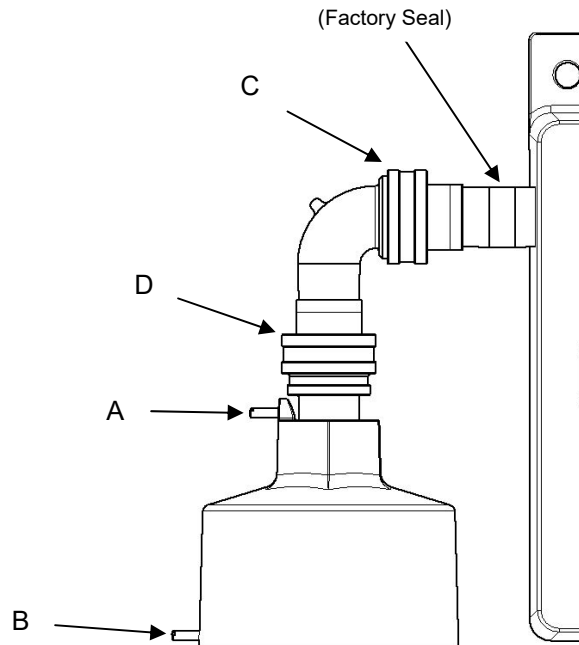

(Figure 3)

## Installation Notes

The EBS System may be installed with the main battery unit in a normally accessible location, while the luminaire heads are located in a remote location.

Remotely mounted EBSEL1030 fixtures can be mounted to a suitable splice box, such as the Killark ¾" / 1" EZA2/EZA3 pendant mount, the EZX2/EZX3 ceiling mount, or the EZB2/EZB3 wall bracket, or the 1 ¼" / 1 ½" EZD4 stanchion mount. Follow instructions for these mounts for installation of EBSEL1030 head.

Remotely mounted EBSHK1030-RFSC / EBSHK1030-RFSL fixtures are intended for surface mounting using the holes provided in the two mounting flanges. Fasten the enclosure to mounting location using a #10 bolts, screws, or applicable mounting hardware. Mount the fixture with its back wall to the mounting wall.

Refer to the Installation Sheet for "Remote Heads for EBS Systems (K1388)" included with the remote LED Luminaire heads for more information.

See "**Conduit Connection and Wiring**" and "**Cable Connection and Wiring**" for details on conduit connection and wiring instructions.

- 1) Verify that the supply voltage and unit voltage are compatible. The unit has the capability of operating at 120-277 VAC 50 or 60Hz, 230 VAC 50 or 60 Hz. Use a single, unswitched supply from a branch circuit used for normal lighting in the area to be protected.
- 2) Remove the battery enclosure's cover 'B' from unit by unscrewing it off of the enclosure counter-clockwise. See **Figure 4** for details. **Note:** Removing cover **automatically disconnects battery**. See **Figure 7** for details.
- 3) Make supply power connections as seen in the **Wiring Schematics** diagram section. For each terminal connection, loosen the screw in the terminal block just enough to allow for the corresponding wire to be inserted. Make sure that any jumpers or connections become loose, and if so, place them in their corresponding locations.

The connection leads for the factory installed EBSHK1030 LED luminaire heads are already terminated at the terminal blocks.

- 4) **Units with Integral Pushbutton Test Station:** Using the **Wiring Schematics** diagrams, verify that factory installed push-button test station is factory wired to proper terminal location.
- 5) **Units with Remote Push-Button Test Station:** Install unit's pushbutton test station per instructions

supplied with the station. Station must be wired to terminal block to provide a method of disconnecting the supply source from the unit. Remote push-button test station is required to be wired through a conduit, which shall be sealed with applicable fittings within 18" of the battery enclosure. **Note:** See **Wiring Schematics 3 or 4 option A or B** for preferred wiring method into EBS23DH main unit.

- 6) Unit ships with battery leads disconnected. Connect (2) battery leads before energizing of circuit. **Remember to perform installation/connection in a non-hazardous atmosphere only.** Do not connect battery leads if branch circuit to which unit is connected cannot be energized, as prolonged battery discharge (battery connected without AC supply present) may damage battery.
- 7) Unpack the Corrosion Inhibitor Vapor Capsule from plastic packaging. Mount capsule using attached adhesive backing to one of the metal brackets in the center of the main battery unit wherever space allows. Replace capsule every 12 months with replacement Killark Capsule. P/N: EBS-VC
- 8) Make sure the external threads of the battery enclosure cover 'B' are free of any dirt, metal chips, or other foreign materials. Apply a thin coat of Killark "LUBT" lubricant to the threads. Thread the battery enclosure cover onto the battery enclosure and turn until there is no gap between the flanges. See **Figure 4** for details.
- 9) Unit is supplied with an **Automatic Battery Safety Disconnect Switch** that will prevent battery power to the luminaire heads if the cover assembly is not properly installed as described in previous step. See **Figure 7** for details.
- 10) Energize unit and verify that proper charging of the fixture is occurring by observing if the red indicator lamp on the bottom of the battery enclosure is on. See **Figure 4** for details.
- 11) Test emergency lamp operation by pressing PUSH-TO-TEST pushbutton 'C' of test station and observe that lamps operate. **NOTE:** If emergency lamps do not operate initially, allow unit to charge for a minimum of 15 minutes then repeat the test. See **Figure 4** for details.
- 12) **EXIT Sign Option:** To install optional EXIT Sign 'E' loosen (4) screws located on globe retaining ring, slip the sign over the screws and rotate to the locked position. Tighten the screws firmly. See **Figure 4** for details.
- 13) **EM Guard Option:** To install optional guard (**Not Shown**), loosen the (4) screws located on globe retaining ring, slip the guard over the screws and rotate to the locked position. Tighten the screws firmly.

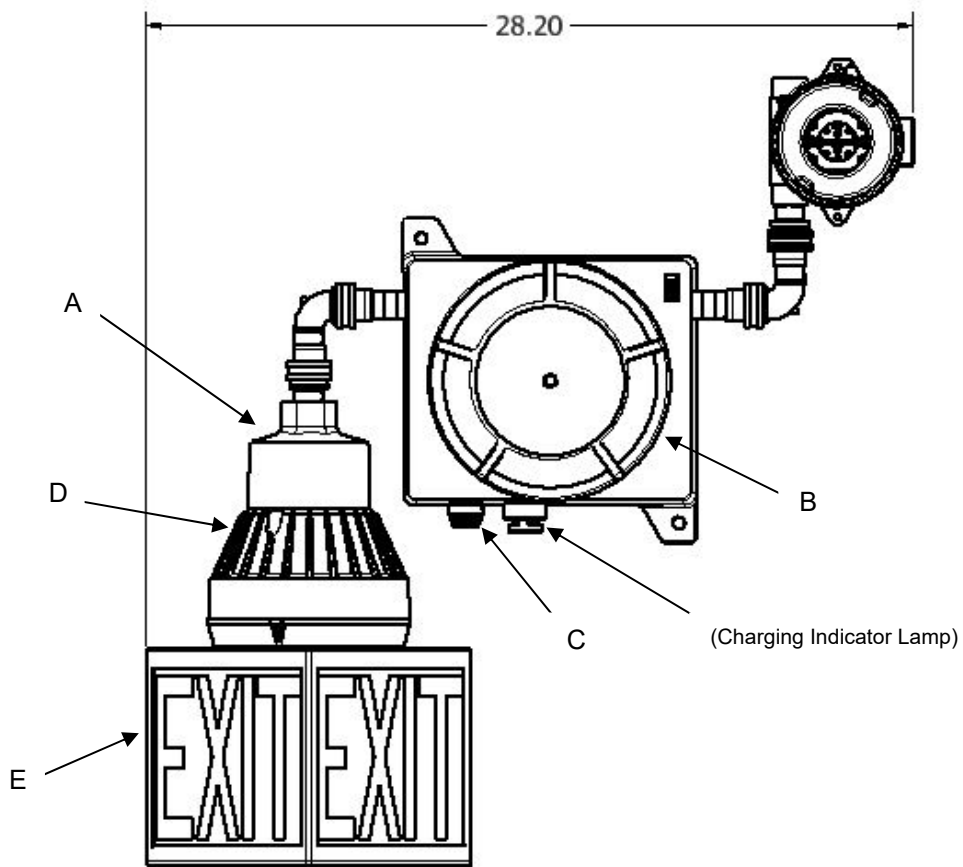

(Figure 4)

### Conduit Connection and Wiring

Connect enclosure to properly grounded conduit system, installing conduit sealing fittings as required by Section 501.15 and, if required, 502.15 of the National Electric Code, plus any other applicable codes.

If cable is utilized, a cable sealing fitting or cable gland must be installed as required by Section 501.15 of the National Electric Code, plus any other applicable codes.

Luminaire Voltage Drop Data		
Wire Size	12 W / 40°C	12 W / 55°C
14 AWG	133 ft	124 ft
12 AWG	211 ft	197 ft
10 AWG	336 ft	315 ft

# Sealing Requirements for Hazardous Locations

## Remote Luminaires and Remote Push-To-Test

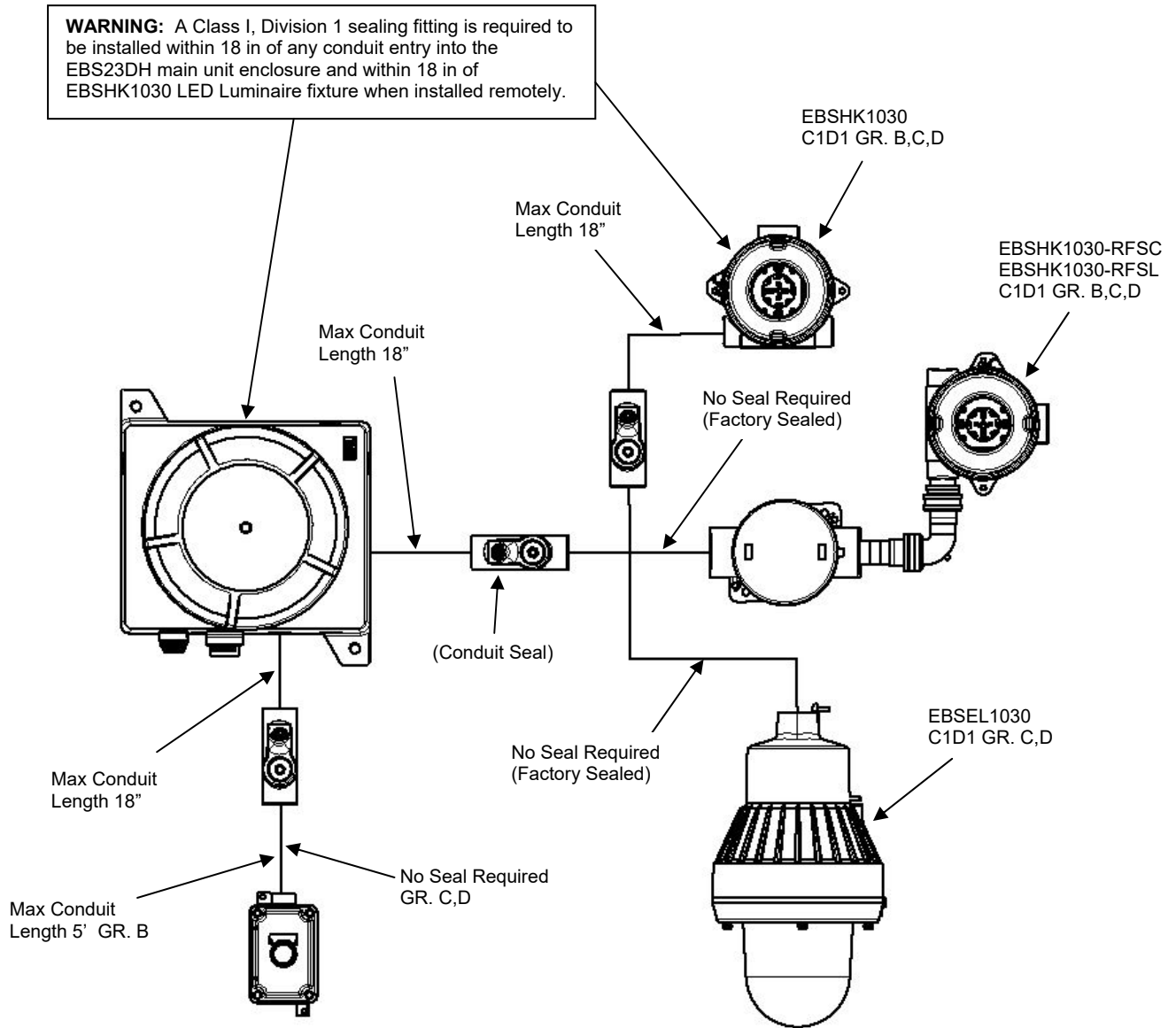

(Figure 5)

**CAUTION:** To prevent explosion, all unused conduit openings must be plugged. Plug must engage a minimum of five full NPT threads. Use Killark CUP-1 or CUP-2 plugs supplied with unit.

## Periodic Testing Instructions

**CAUTION:** Turn **OFF** the supplying circuit before beginning installation or performing any maintenance, including re-lamping. With power turned off, service must be done in non-hazardous atmosphere. Service should be performed by qualified service personnel.

**Important:** Make sure to keep an up-to-date record of all testing done in order to have adequate record of maintenance. Failure to function properly in either the monthly or annual test may indicate failure and need for replacement of the battery/ballast assembly (**KLBP01**) or the LED luminaire assembly.

Article 700 of the National Electric Code states that, "Systems shall be tested periodically on a schedule acceptable to the authority having jurisdiction (AHJ) to assure their maintenance in proper operating condition". It also states that, "A written record shall be kept of such tests and maintenance."

In the absence of periodic testing requirements by a local AHJ, the following recommendations are made by the NFPA 101 (2003) Life safety code:

**Monthly:** Operate the Push-to-Test switch and keep depressed for a minimum of 30 seconds. Observe that the emergency LED luminaires are on full brightness for the entire time. Record the test on the **Maintenance Record Sheet**. This sheet is included in this IOM Manual.

**Annually:** Shut off power at the distribution panel. Verify that the emergency LED luminaires remain on for a minimum of 1 ½ hours.

**If replacement of battery/ballast assembly (KLBP01) or LED luminaire assembly is needed:**

- 1) Turn off supplying power to the circuit and disconnect from the supply using standard lockout/tag out procedures. Lock-out / tag-out can also be accomplished with accessory GO10502 for integral Push-To-Test button or remote EBS-PTT-LO.
- 2) Remove the battery enclosure cover (**Figure 4, Item B**). **Do Not Depress the Automatic Battery Disconnect Switch (Figure 7)**, as this will put power to the heads from the battery, remove the standard automotive 2A, blade fuse (e.g. LITTELFUSE Model: MIN2) from the yellow fuse holder. This will disconnect the batteries from the circuit. See **Figure 6** for more details.
- 3) **With power turned off, service must be done in non-hazardous atmosphere.**
- 4) Use authorized Killark replacement parts.
- 5) Re-install EBS system using original installation instructions, verifying that all terminations are correct, and all attachments are to factory specification.

**Fuse Removal**

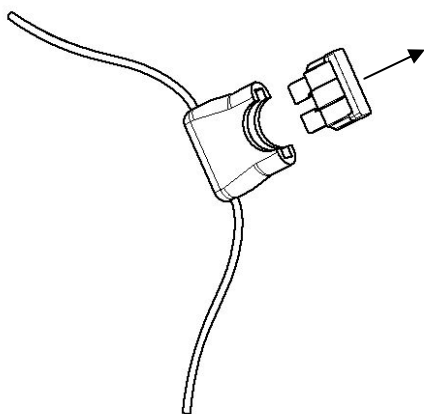

**(Figure 6)**

**Internal Components**

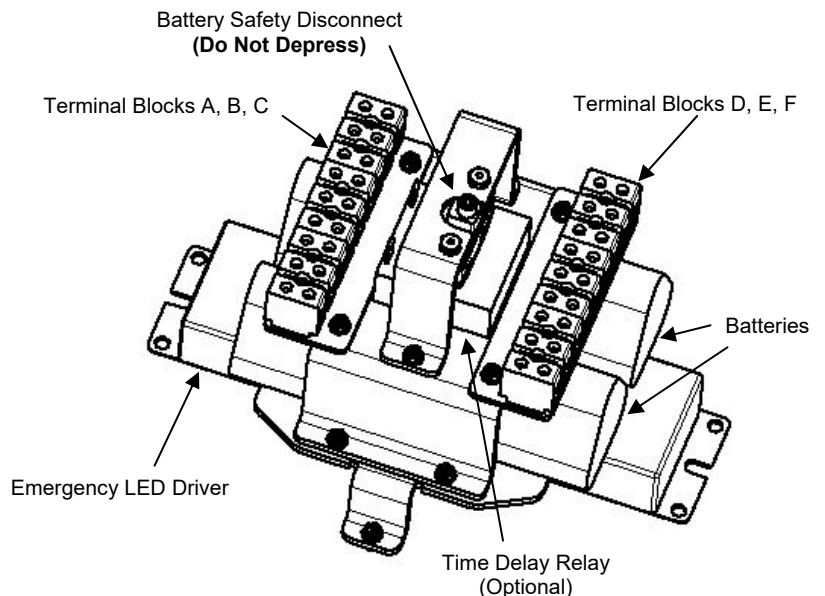

**(Figure 7)**



# Wiring Schematics

## EBS23DH Internal Wiring (Main Unit)

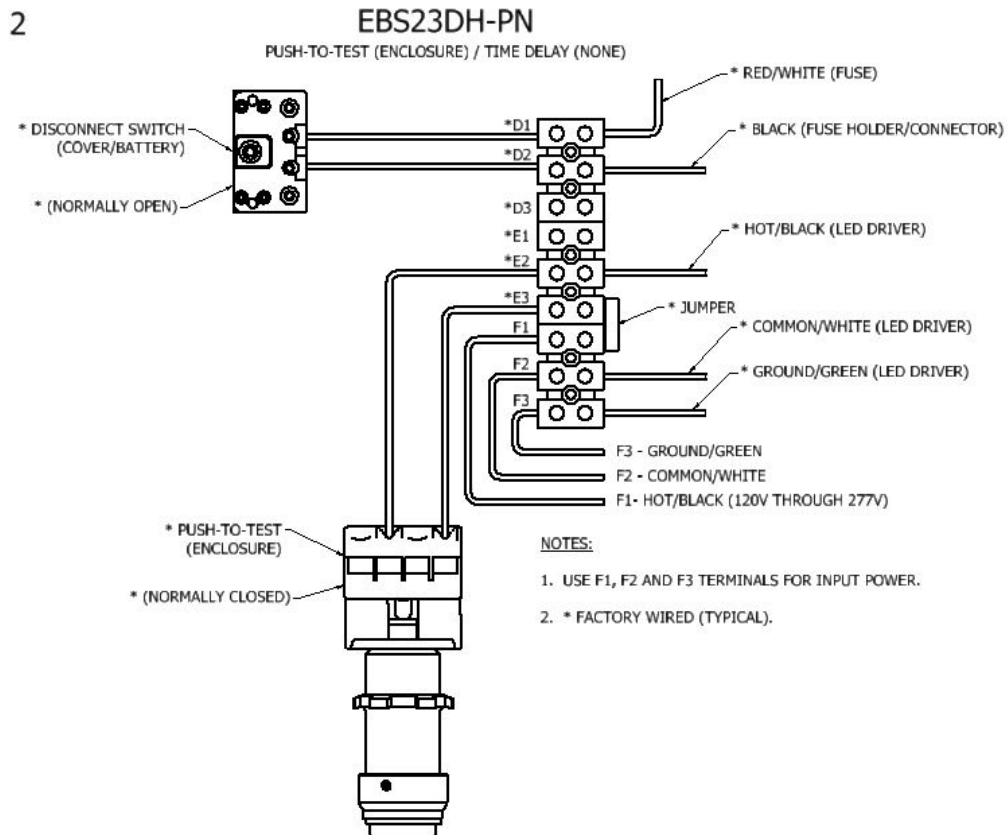
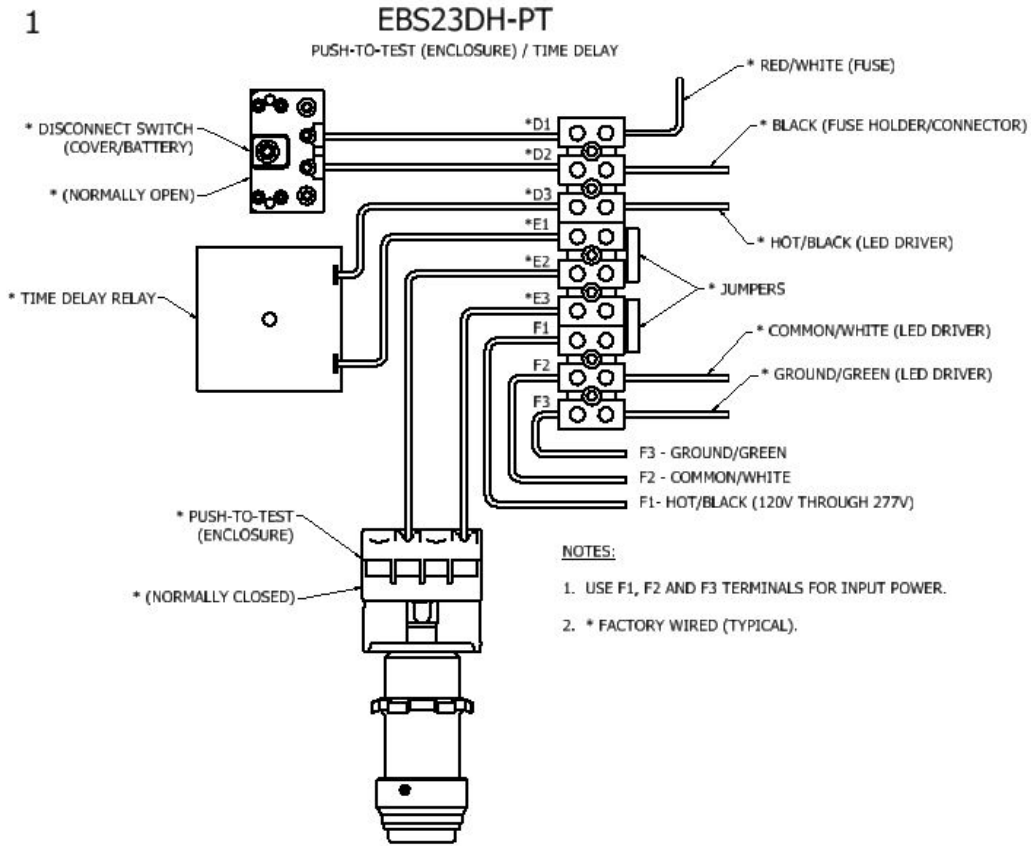

3A

### EBS23DH-RT

PUSH-TO-TEST (REMOTE) / TIME DELAY  
INPUT POWER WIRED THROUGH PUSH-TO-TEST

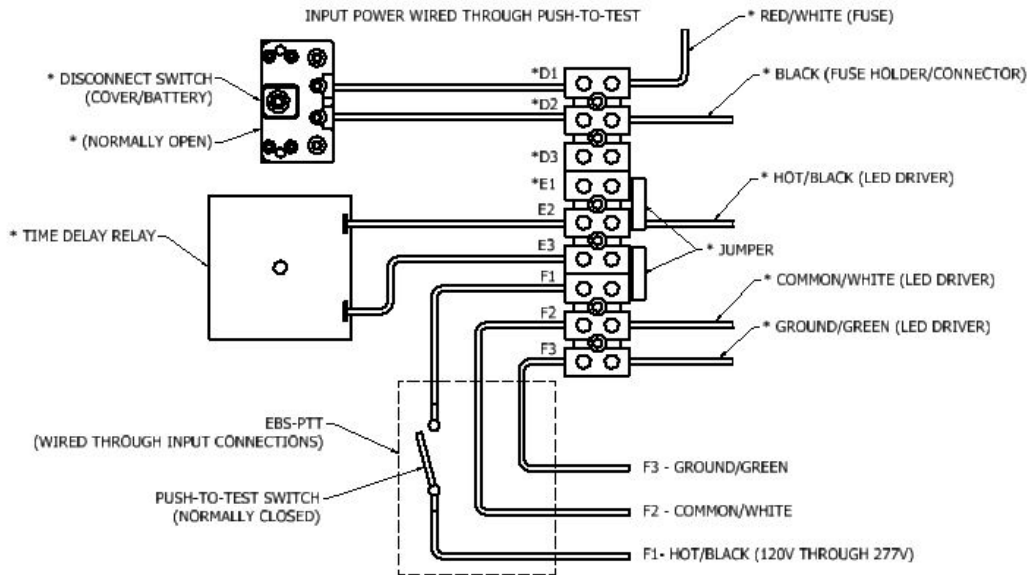

**NOTES:**

1. USE F1, F2 AND F3 TERMINALS FOR INPUT POWER.
2. \* FACTORY WIRED (TYPICAL).

3B

### EBS23DH-RT

PUSH-TO-TEST (REMOTE) / TIME DELAY  
PUSH-TO-TEST WIRED FROM ENCLOSURE

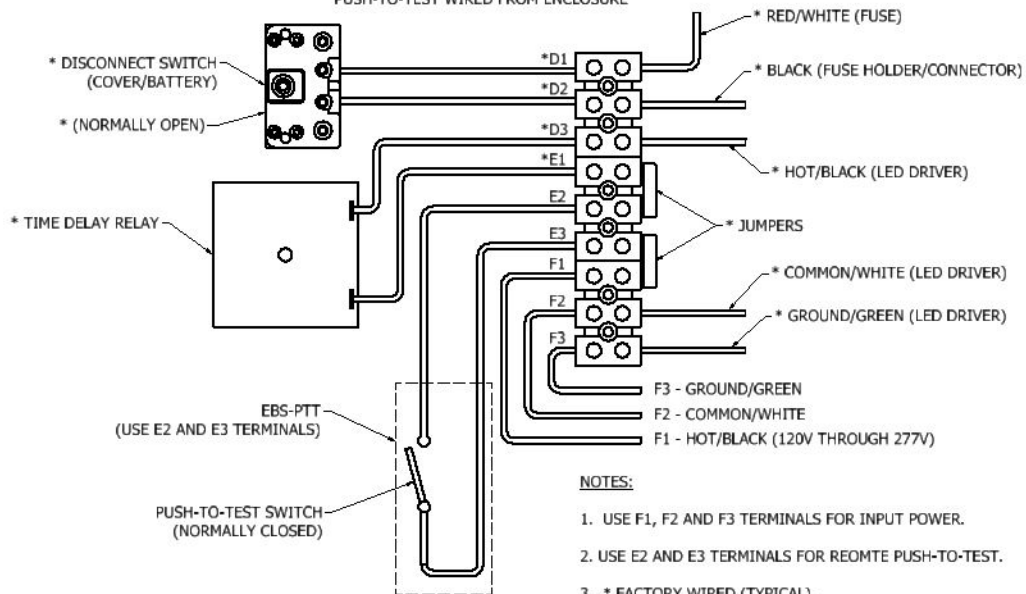

**NOTES:**

1. USE F1, F2 AND F3 TERMINALS FOR INPUT POWER.
2. USE E2 AND E3 TERMINALS FOR REMOTE PUSH-TO-TEST.
3. \* FACTORY WIRED (TYPICAL).

4A

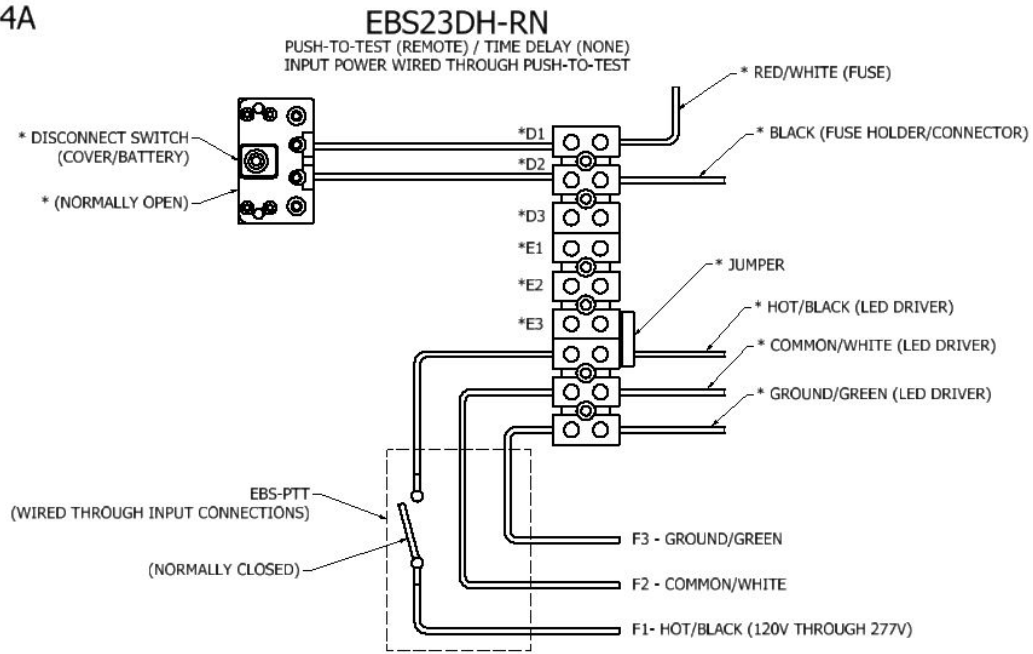

**NOTES:**

1. USE F1, F2 AND F3 TERMINALS FOR INPUT POWER.
2. \* FACTORY WIRED (TYPICAL).

4B

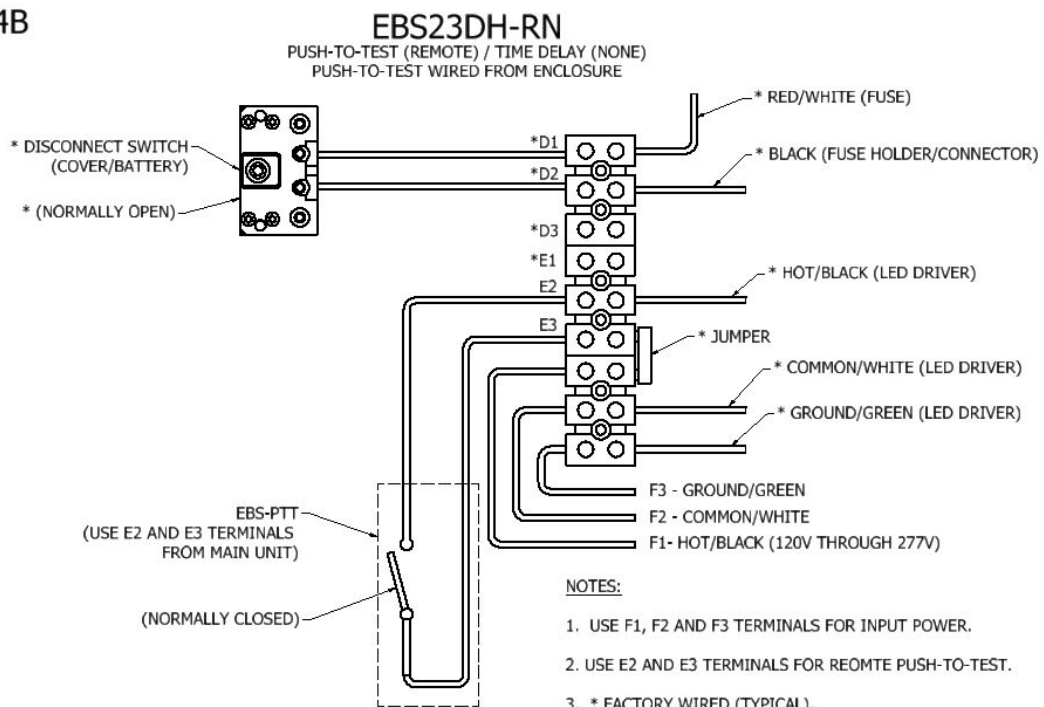

**NOTES:**

1. USE F1, F2 AND F3 TERMINALS FOR INPUT POWER.
2. USE E2 AND E3 TERMINALS FOR REMOTE PUSH-TO-TEST.
3. \* FACTORY WIRED (TYPICAL).

5

**EBS23DH-NT**  
 PUSH-TO-TEST (NONE) / TIME DELAY

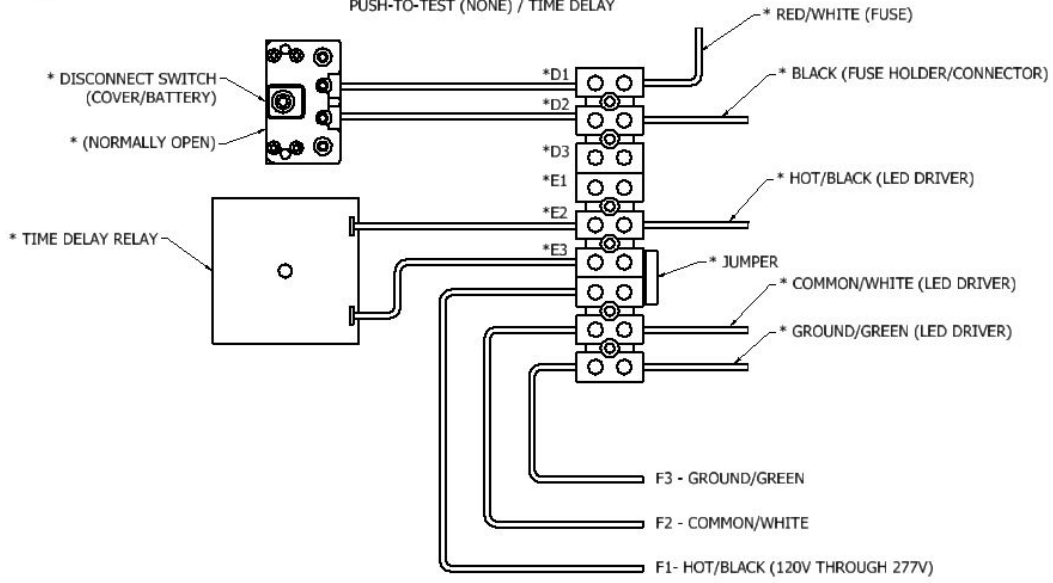

NOTES:

1. USE F1, F2 AND F3 TERMINALS FOR INPUT POWER.
2. \* FACTORY WIRED (TYPICAL).

6

**EBS23DH-NN**  
 PUSH-TO-TEST (NONE) / TIME DELAY (NONE)

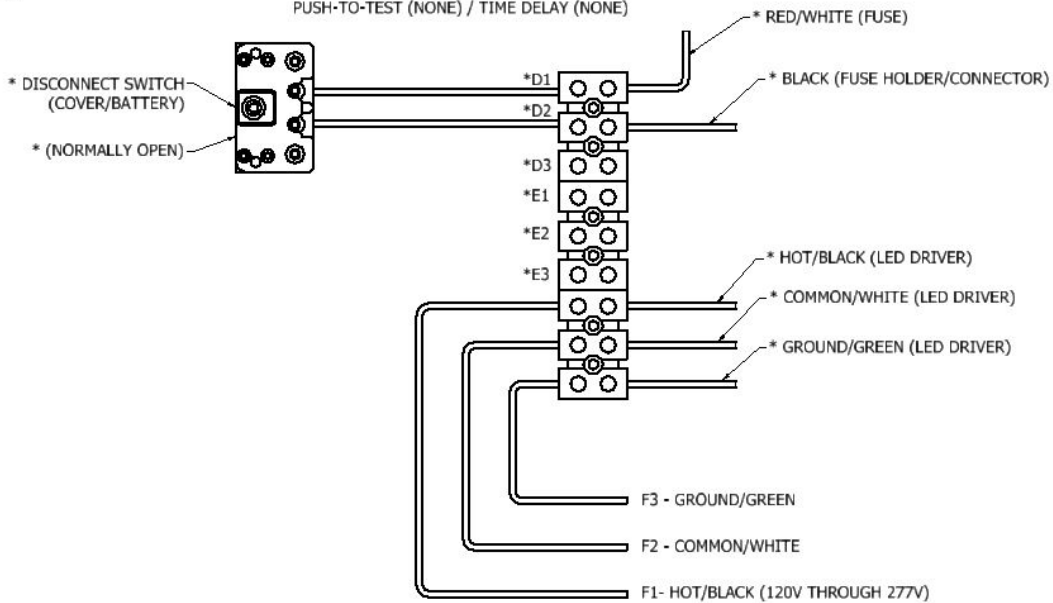

NOTES:

1. USE F1, F2 AND F3 TERMINALS FOR INPUT POWER.
2. \* FACTORY WIRED (TYPICAL).

EBSHK1030 or EBSEL1030 Remote Fixtures

7

EBSHK1030 OR EBSEL1030

(Two Fixtures at 350mA ea.)

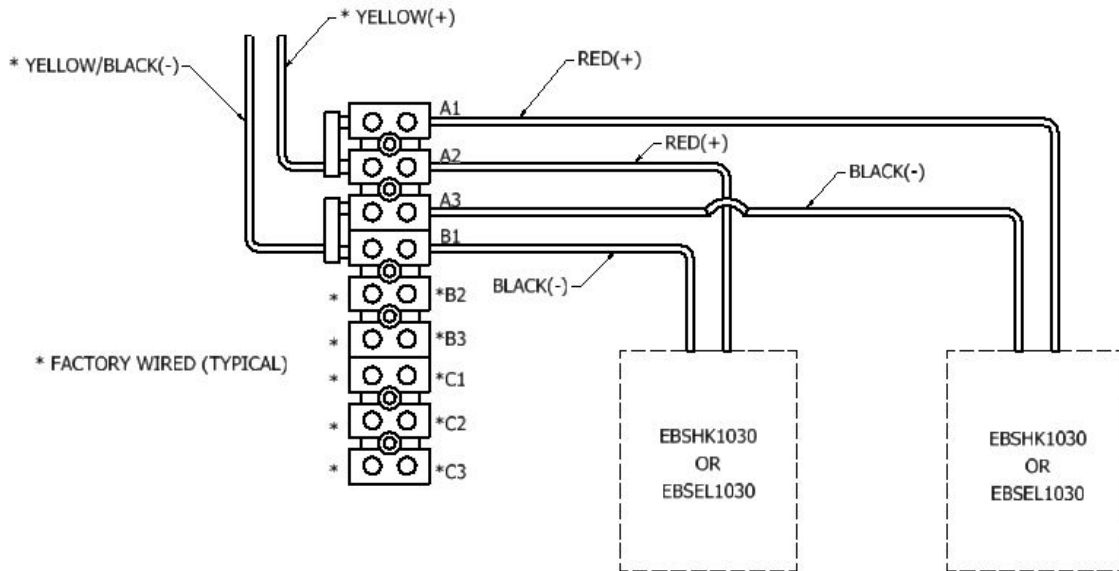

8

EBSHK0130 OR EBSEL1030

(Four Fixtures at 175mA ea.)

