



HUBBELL ELECTRICAL PRODUCTS  
A Division of  
HUBBELL  
INCORPORATED  
(Delaware)  
3940 Martin Luther King Drive  
St. Louis, Missouri 63113 USA

## INSTALLATION, OPERATION & MAINTENANCE DATA SHEET FOR KFLC SERIES LED LUMINAIRE FLOOD

Luminaires are designed to be installed in Class I, Division 2, Class II, Division 1, or Class I Zone 2 Hazardous locations.

**CAUTION:** Before installing luminaire, make sure luminaire complies with area classifications, failure to do so may result in bodily injury and/or property damage. Do not attempt installation until you are familiar with the following procedures. All installation must comply with the applicable local and/or National Electrical Code and be performed by a qualified electrician. Make sure that the circuit is de-energized before starting installation or maintenance.

Verify that luminaire is grounded. Failure to ground will create electrical shock hazards, which can cause serious injury and or death.

**NOTE-** For Class I, Division 2 / Class II, Division 1 / Class I, Zone 2 Hazardous Locations, use rigid conduit or appropriate cable connector.

### INSTALLATION INSTRUCTIONS:

#### FLOOD LIGHT WITH YOKE MOUNT: (See Figure 1)

1. For convenience, install the yoke bracket on the trunnion before mounting the structure.
2. Loosen bolts - aim the floodlight to the desired spot.
3. Tighten both bolts securely.
4. Fasten the yoke bracket to the mounting location using 1/2" bolts/fasteners.



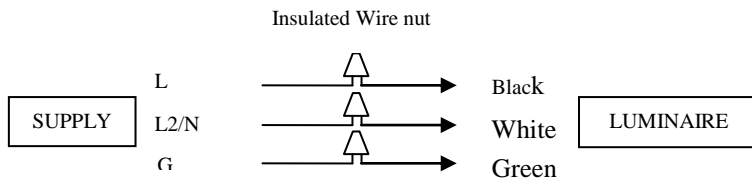
**Figure 1**

**IMPORTANT NOTE:**

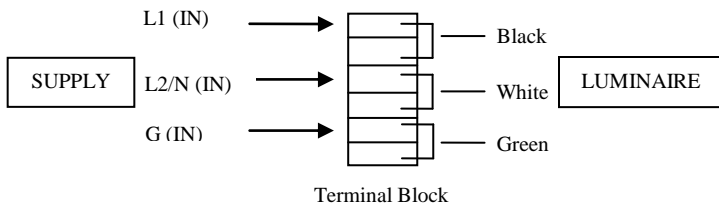
Turn off electricity to circuit at main fuse or at circuit breaker.

1. Loosen and remove the six (6) lens frame screws. Remove lens frame assembly to allow for entry into fixture. See **Figure 2** for more details
2. Run supply wire to fixture through applicable hub. Make watertight joint using sealing fittings at appropriate hole. The included hub is for 3/4"-14NPT. A 1/2"-14NPT reducer is also included.
3. CAUTION - Connection as described below requires the use of either insulated wire nuts or, as an alternate, an optional factory installed terminal block assembly. See below:

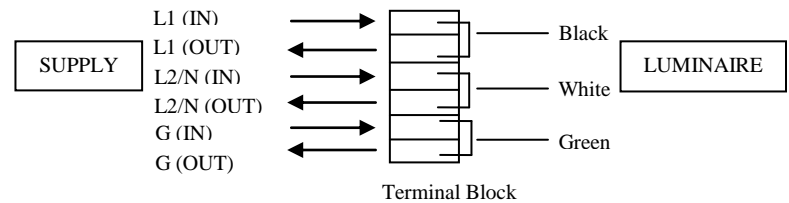
**Standard Connection Method (Insulated Wire Nuts)**



**Connection Method (Insulated Terminal Block Assembly) Standard Wiring Method**

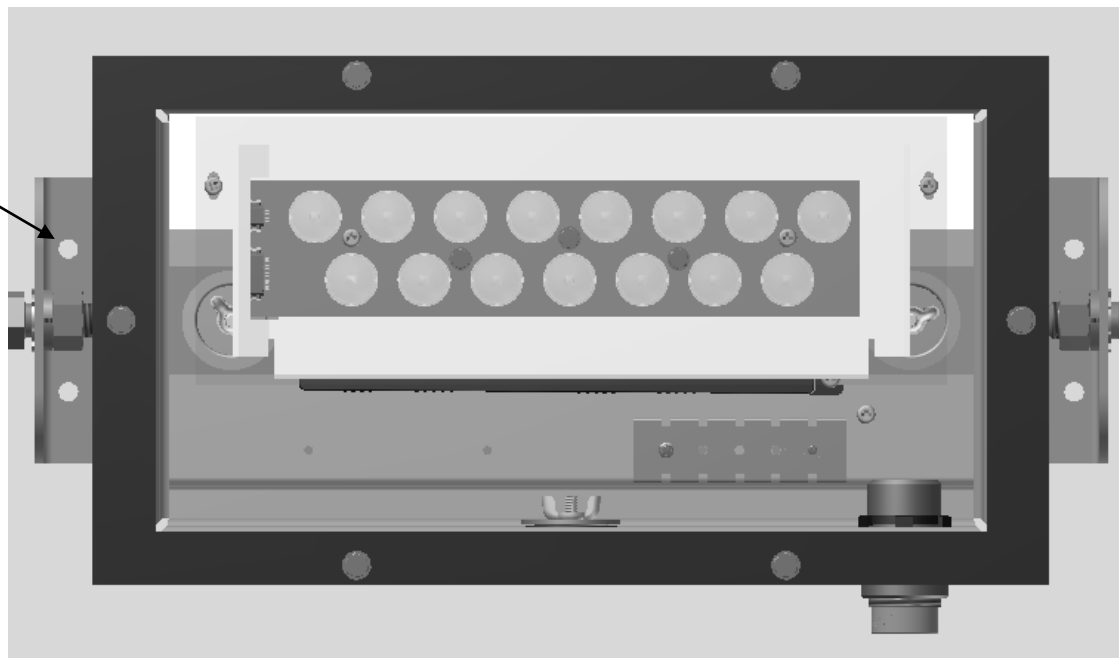


**Connection Method (Insulated Terminal Block Assembly) Loop In / Loop Out Wiring Method**



4. Replace lens assembly screws. Securely tighten screws. See **Figure 2** for more details.
5. Turn on electricity to verify fixture is operating properly

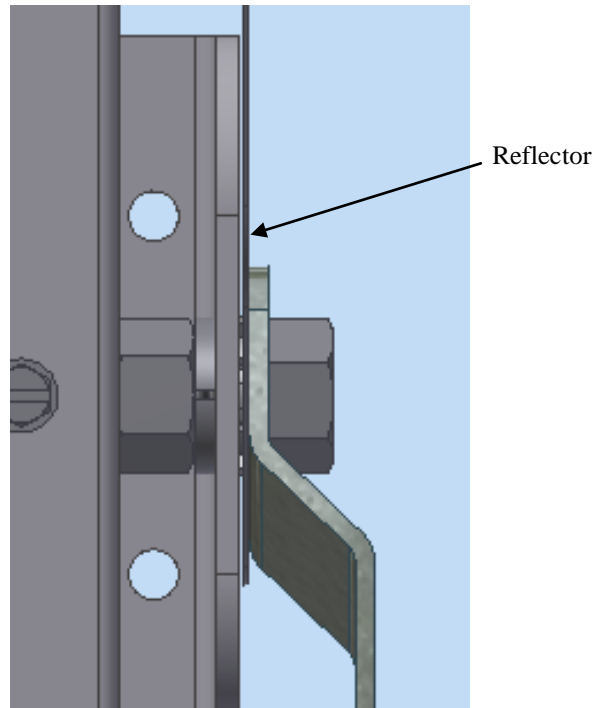
Mounting holes for flush mounting without yoke.



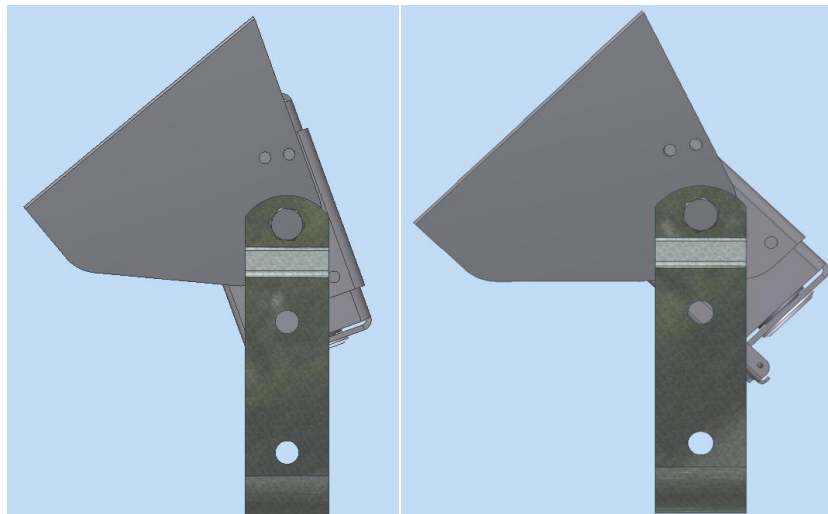
**Figure 2--Fixture Shown with Lens Cover Removed**

**OPTIONAL DARK SKIES REFLECTOR AND GUARD**

1. Place reflector between the yoke and the star washer. See **Figure 3**
2. To place the dark skies reflector properly when the fixture is aimed at 70 degrees with respect to the ground, align the back hole in the reflector with the hole in the body. See **Figure 4**
3. To place the dark skies reflector properly when the fixture is aimed at 45 degrees with respect to the ground, align the front hole in the reflector with the hole in the body. See **Figure 5**.
4. The guard snaps over the front of the fixture. See **Figure 6**.

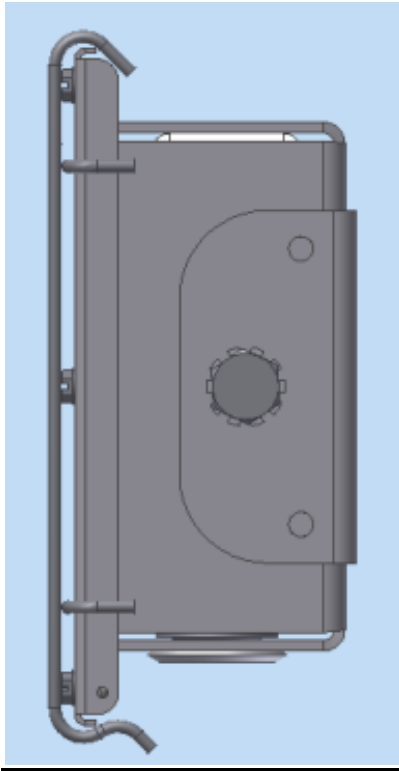


**Figure 3**  
**Reflector Assembly**



**Figure 4**  
**70° Mounting Shown**

**Figure 5**  
**45° Mounting Shown**



**Figure 6**  
**Guard Assembly**

**MAINTENANCE INSTRUCTIONS:**

**CAUTION:**

Disconnect the supplying circuit before opening fixture or removing optics. To maintain maximum light output, this fixture should be cleaned periodically. Maintenance procedures sometimes require fixtures to be hosed down for good housekeeping. The supply circuit **must** be turned **OFF** and the fixture lens **must** be allowed to cool to the ambient room temperature before cleaning. Only mild, non-abrasive cleaning agents should be used. The force of water applied by a hose must not exceed 65 gallons per minute coming from a 1" diameter hose applied at a distance of 10 feet. These periodic cleaning procedures are important to prevent the accumulation of dust and dirt which will impair the light output of the fixture. The glass lens should be regularly inspected for scratches and chips and, if damaged, must be replaced.

**HIGH VIBRATION AREAS:**

Periodic inspection of lens tightness is required; recommended every six (6) months.

Technical information, advice and recommendations contained in these documents are based on information that Killark believes to be reliable. All the information and advice contained in these documents is intended only for use by persons having been trained and possessing the requisite skill and know-how and to be used by such persons only at their own discretion and risk.

The nature of these instructions is informative only and do not cover all of the details, variations or combinations in which this equipment may be used, its storage, delivery, installation, check out, safe operation, and maintenance. Since conditions of use of the product are outside of the care, custody and control of Killark, the purchaser should determine the suitability of the product for its intended use, and assumes all risk and liability whatsoever in connection therewith.

**REMEMBER TO SAVE ONE OF THESE SHEETS FOR MAINTENANCE PERSONNEL**