



# INSTALLATION, OPERATION & MAINTENANCE DATA SHEET

## VSQ SERIES 30 AMP INTERLOCKED SWITCHED RECEPTACLES

**CLASS I, GROUPS B,C,D; CLASS I ZONE 1, GROUPS IIB, IIA +H2; CLASS II, GROUPS F & G; & CLASS III HAZARDOUS LOCATION ENCLOSURE TYPES 3, 4, 4X & 12.**

**All Installations Must Comply With Applicable Local, National Electrical Codes, and/or Canadian Electrical Code.**

**To Prevent Ignition of Hazardous Atmospheres Do Not Use in Class II, Group E Locations that Contain Electrically Conductive Dusts.**

### APPLICATIONS

- VSQ series dead front interlocked receptacle with switch is suitable for use in hazardous locations.
- Designed for supplying power to fixed or portable electrical equipment.

### ELECTRICAL RATING

- Maximum voltage - 600 VAC @ 50-400Hz. Continuous Current - 30Amperes.

### INSTALLATION

- Carefully Read and understand the following instructions before installation & operation of this device.
- **Note:** All Installations must comply with Applicable Local, National Electrical Code and/or Canadian Electrical Code.
- **Note:** VSQ covers can not be used on VWSQ mounting boxes, which are intended for non-hazardous location installations.
- **Warning:** Make sure the receptacle assembly is suitable for use in desired location per applicable local and/or National Electrical Code. Serious damage and/or injuries may result due to improper applications. Electrical power must be turned OFF before and during the installation & maintenance. Fatal injury and/or damage may result by not following these instructions.
- **Mounting Arrangement:** Receptacle assembly must be mounted securely onto a column, wall, or other structure that is able to support the device and the associated conduit system. The structure is to be prepared for use of four (4) 3/8" steel bolts (furnished by others) using the lugs on the housing. The spacings are as shown in Fig. 1. The device is equipped with factory installed hinges. It must be mounted with the hinges on the bottom and the receptacle in the downward direction.
- **Conduit Installation:**
  1. 1" NPT conduit entries are provided on the top and bottom of the housing.
  2. All conduit entries must be sealed within 18" of the enclosure as per National Electrical Code.
  3. Make sure conduit entries are clean before installing conduit, close-up plugs, reducers, etc. Killark "LUBG" thread lubricant is recommended for this application.

**Warning:** Use only copper cable or wire for the range indicated in the table. **Use 75°C rated conductors (minimum).**

	Wire Range	Strip Length	Torque
Switch	#10 - #8	0.750 inches	20 in.-lb.
Ground	#16 - #6	0.500 inches	20 in.-lb.

- **Wiring:**
  1. Develop and establish the wiring pattern for your system. Locations having different voltages and/or frequencies must not have interchangeable attachment plugs. Always test before energizing.
  2. Make sure to pull sufficient length of supply conductors to connect to the enclosed terminals.
  3. Strip the conductors to the length shown in table.
  4. Loosen the switch terminal screws and wrap the stripped conductors securely around the terminal screws. Tighten the terminals to the torque specified in the table.
  4. Connect the conductors to the ground and phase terminals securely and tighten to the values shown in the table.
- **Inspect & Clean Flange:** The machined flange surface of both the box and cover must be smooth, free of nicks, scratches, dirt, or any foreign particle build-up that would prevent proper seating. Surfaces must seat fully against each other to provide a proper flame path joint. Clean surfaces by wiping with a clean, lint free cloth. Apply a light coating of "LUBG" lubricant to flange surface.
- **Cover Securement:** Close the cover then install and tighten all cover bolts to 25 ft.-lb. Make sure no cover bolts are omitted. Use only those bolts supplied with the device. Check the bolted joint with a .0015" feeler gauge. The gauge must **not** enter the joint more than 1/8" at any point.
- **Caution:** Missing bolts or an improper joint can result in an explosion, creating the potential for serious or fatal physical injury and/or property damage.
- **Cover Replacement:** The power must be disconnected before removing the cover. Remove the bolts and reverse the wiring procedure. Once the conductors have been detached, remove the screws that hold the cover to the hinges (4 total). Line up the new cover with the hinges and reinstall the hinge screws. Once the hinges are attached repeat the wiring, inspect & clean flange and cover securement procedures.

## OPERATION

- **Caution:** The switch cannot be turned **ON** without fully inserting an approved plug (see list below). A plug cannot be inserted or withdrawn unless the switch is **OFF**. To remove the plug turn the switch to the **OFF** position and pull back on the locking pin knob while pulling on the plug.
- **Note:** Switch cannot be operated until the locking pin has fully engaged the plug.

## ROUTINE INTERLOCK VERIFICATION

- **Warning:** Perform this test before energizing the receptacle.
- Before inserting the plug verify that the switch can **not** be turned to the **ON** position.
- Insert the plug, turn the switch to the **ON** position, pull on the locking pin knob and verify that the plug can **not** be withdrawn **without** turning the switch to the **OFF** position.
- If the receptacle does not perform properly **discontinue use immediately!**

## ELECTRICAL TEST

- **Warning:** Perform this test before energizing the receptacle.
- Test continuity of wiring to verify correct polarity, phasing, and grounding connections.
- Measure insulation resistance to be sure the system does not have any shorts or unwanted grounds.

## MAINTENANCE

- Electrical and mechanical inspection of all components must be performed regularly. It is recommended that an inspection be performed a minimum of once a year.
- Inspect all terminals for tightness (**Retorque**). Discoloration due to excessive heat is an indicator of possible problems and should be thoroughly investigated and repaired as necessary.
- Inspect grounding and bonding for correct installation and secure connection (**Retorque**).
- **Warning: Do not modify these devices in any way.** Replace with proper replacement part(s) supplied by Killark before continuing service. Failure to do so could cause serious or fatal personal injury and/or equipment damage.
- Inspect gaskets for deterioration and replace if necessary.
- Clean exterior surfaces making sure nameplates remain legible.
- Torque all bolts and screws as described in the instructions before reusing the device.

- Inspect receptacle thread used for plug locking ring for proper lubrication. Apply Killark "LUBG" type lubricant or equivalent to thread surfaces as required to prevent galling between the receptacle and locking ring threads.
- In addition to these required maintenance procedures, we recommend an Electrical Preventive Maintenance Program as described in the National Fire Protection Association Bulletin NFPA No. 70B.

### WARNING

Electrical power supply **MUST BE OFF** before and during installation and maintenance. **DISCONNECT** primary power source and **LOCK OUT**. Installations and maintenance procedure must be performed by a trained and competent electrician

### WARNING

If any parts of the plug, receptacle, or switch appear to be missing, broke, or show the signs of damage. **DISCONTINUE USE IMMEDIATELY!**

### Replacement Parts: (Cover Only)

- VSQ3023-COV
- VSQ3034-COV
- VSQ3023-S37-COV
- VSQ3034-S37-COV

- **Note:** The S37 suffix designates a polarized receptacle.

FIGURE 1

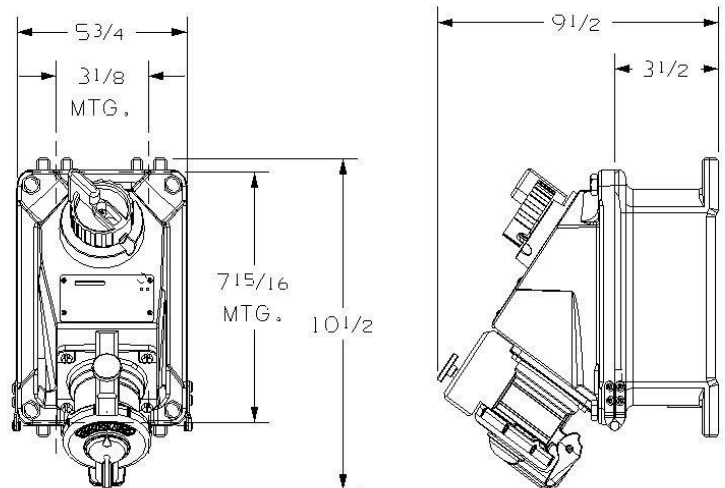

## INTERMATEABILITY FOR PLUGS

Device	Killark Plug	Crouse Hinds Plug	Appleton Plug
VSQ3023	VP3385	APJ3385, NPJ3383, NPJ3384	ACP3023BC
VSQ3034	VP3485	APJ3485, NPJ3483, NPJ3484	ACP3034BC
VSQ3023-S37	VP3385-S37	APJ3385-S4, NPJ3383-S4, NPJ3384-S4	ACP3023BC-P4
VSQ3034-S37	VP3485-S37	APJ3485-S4, NPJ3483-S4, NPJ3484-S4	ACP3034BC-P4