

DESCRIPTION

Hubbell Control Solutions wall mount occupancy sensors are designed to reduce installation time and prevent callbacks resulting from improper sensor adjustment. Hubbell sensors study their environment and automatically adjust the time delay and sensitivity to optimize the sensor's performance for the specific application. Hubbell LightOWL sensors must be used in conjunction with Hubbell UVPP series control units. The control units provide a 24VDC power supply for 1 to 4 sensors. The correct control unit must be selected for the operating voltage of the application.

PRE-INSTALLATION

1. NOTICE: For installation by a qualified electrician in accordance with national and local codes and the following instructions.
2. CAUTION: RISK OF ELECTRICAL SHOCK. Disconnect power before installing. Never wire energized electrical components.
3. CAUTION: USE COPPER CONDUCTORS ONLY.
4. Check to see that the device's rating is suitable for the application.
5. NOTICE: Do not install if any damage to product noted.

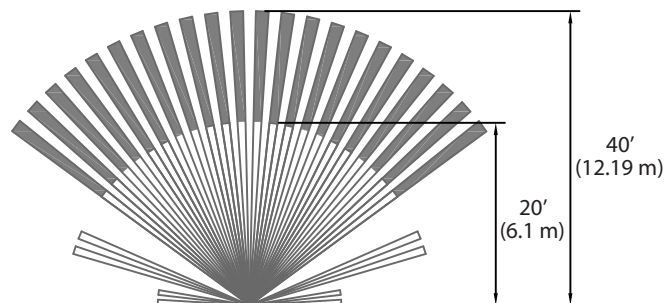

FIG. 1

COVERAGE AND PLACEMENT FIG. 1&2

The pattern of the LOIRWVRP-LWO sensor is shown in FIG. 1 at right.

- Sensor must be used with appropriate enclosures and/or fitting to maintain NEMA 4X rating.
- Sensor must be mounted with the access port at the bottom.
- Sensor can be wall or ceiling mounted.
- Sensors should NOT be installed near a stream source or an environment with an elevated heat environment.
- Do NOT install in view of strong direct or reflected light sources.

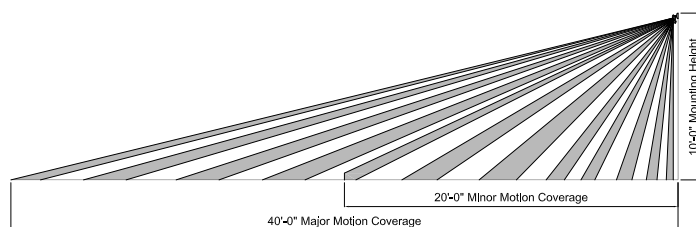

FIG. 2

INSTALLATION OF SENSORS FIG. 3

1. Disconnect Power
2. Install UVPP series control unit(s) and, if applicable, auxiliary Relay(s). See installation instructions for these products.
3. Run 3 conductor low voltage cable (18 to 22 AWG type CL2, CL2P, CL2PR, or CMR as appropriate) from control unit to sensor location(s) per wiring diagram FIG. 3. Maximum cable length between power unit and farthest sensor is 250 feet (76 meters).
4. Confirm the correct coverage by simulating typical motion in the coverage area. To test the sensor, remove the access plate and press the TIMER TEST MODE BUTTON FIG. 5. The lights will now turn off 8 seconds after motion stops. If the desired coverage is not achieved, re-aim the sensor or relocate it. After testing, push and hold the switch to return to the normal timer mode. Reinstall access cover and torque screw 10-12 lb-in (1.1 - 1.4 N-M). After position of sensor is confirmed, torque pivot screws 10-12 lb-in (1.1 - 1.4 N-M).

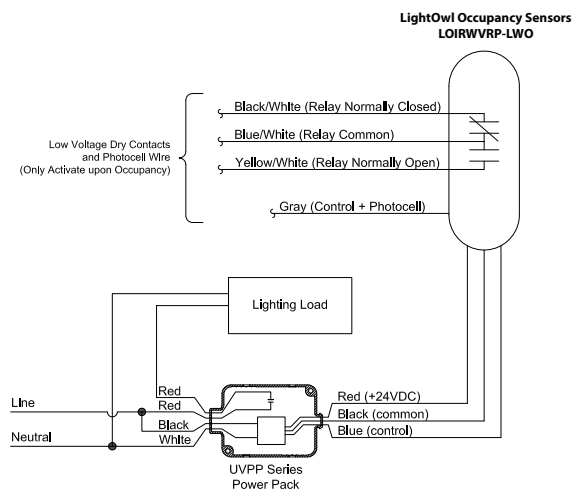

FIG. 3

ISOLATED RELAY FIG. 4

The isolated relay can be used to interface the sensor with an auxiliary system. Normally open and normally closed contacts are available. For normally open contacts, utilize the yellow/white and blue/white wires. For normally closed contacts, utilize the black/white and blue/white wires. Contact Rating (SPDT): 500ma @ 30VDC max.

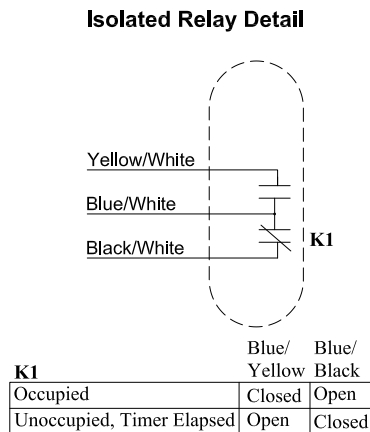

FIG. 4

AMBIENT LIGHT LEVEL CONTROL FIG. 5

The sensor is factory preset to turn the lights on regardless of the daylight level. Setting the daylight level control will prevent the lights from turning on when the daylight is above the set level. The daylight must be at the desired level to properly set this feature. To set the daylight level control:

1. Remove the access plate. Press the TIMER TEST MODE BUTTON to activate the 8 second test mode. FIG 5.
2. Adjust the photocell knob fully counter clockwise. This will keep the lights off regardless of the ambient light.
3. Leave the sensor's coverage area. The lights should turn off after about 8 seconds. When the lights turn off, re-enter the area.
4. Slowly turn the photocell knob clockwise until the lights turn on. The sensor is now set to prevent the lights from turning on when the daylight level is above the set threshold.
5. Press and hold the timer test mode switch until lens flashes to return to the normal timer mode. Reinstall access cover and torque screw 10-12 lb-in (1.1 - 1.4 N-M).

SENSOR CONTROLS & MODIFICATIONS

Hubbell Control Solutions sensors are designed to optimize performance by automatically adjusting the timing and sensitivity to meet the application. The sensor controls can be modified for custom operation. The modification options are outlined below.

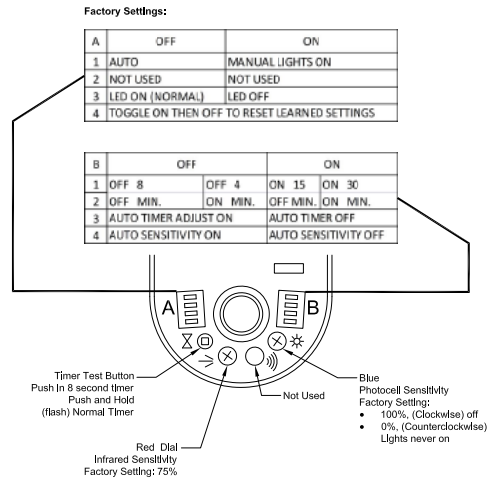

FIG. 5