

INSTRUCTIONS FOR INSTALLATION, OPERATION and MAINTENANCE

CHANCE TYPE M3 STATION SWITCH

GENERAL

! WARNING

Read and understand these instructions before installation or operation of this equipment. Competent personnel who understand proper safety procedures must select, install, and service this equipment. This instruction guide is written for such personnel. This guide is not a substitute for adequate training and experience in safety procedures for this type of equipment.

The A. B. Chance Type M3 disconnect switch is a single-phase hookstick operated switch. It is for manual switching of de-energized or parallel circuits of overhead lines on an electrical distribution system. The M3 switch has no current making or breaking capacity. Design variations allow for applications as an electrical distribution switch or as an electrical station switch. A number of options (connectors, captive hardware, by-pass studs, etc.) are available to better fit the user's needs.

The station style M3 disconnect switch is made for mounting in an inverted (**Figure 1**) or vertical position (**Figure 2**).

Select a properly rated M3 switch for each installation with consideration to continuous current, BIL, and rated voltage. Should there be any concern on the use of this M3 switch as rated, consult your supervisor before installation.

Inspect the switch for damage or missing parts. If damage from rough handling is evident, immediately file a claim with the transportation company. Contact the nearest Chance sales office for replacement parts.

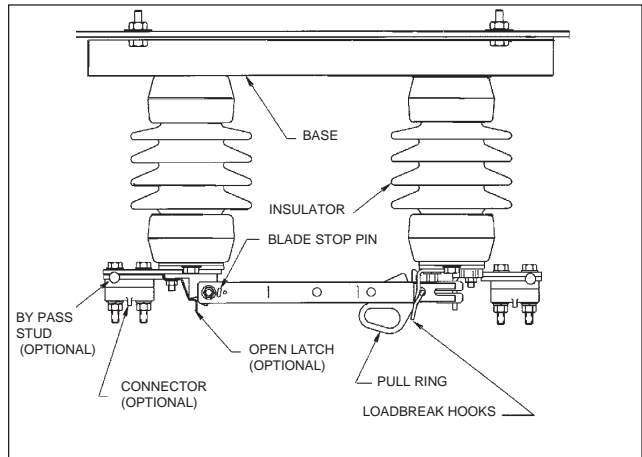

Figure 1 — Inverted-Underhung

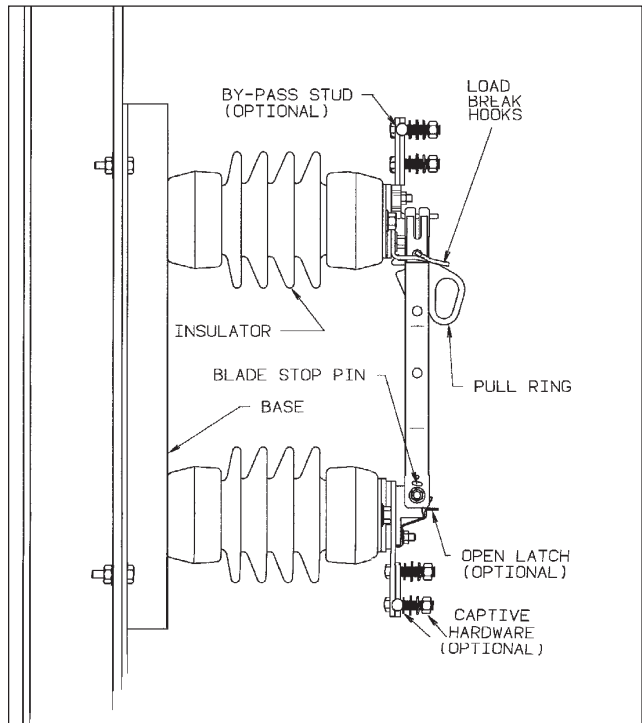

Figure 2 — Vertical Mount

These instructions do not claim to cover all details or variations in equipment, nor to provide for all possible conditions to be met with concerning installation, operation, or maintenance of this equipment. If further information is desired or if particular problems are encountered which are not sufficiently covered in this guide, contact A. B. Chance Company.

NOTE:

Because Hubbell has a policy of continuous product improvement, we reserve the right to change design and specifications without notice.
© Copyright 1996 Hubbell / Chance, 210 N. Allen, Centralia, MO 65240 Printed in USA



POWER SYSTEMS, INC.



Part No. P807-0199
Rev. C 6/96

INSTALLATION

The M3 switch is supplied with a blade stop pin. Before raising switch for mounting, place this pin in the proper hole to obtain either a 90° or 160° (**Figure 3**) blade opening. Some switches may be supplied with an open blade latch. The stop pin must be in the 160° hole, as shown in **Figure 3**, to engage the open blade latch.

Attach the M3 switch to the mounting structure using 1/2" hardware supplied by user. The station switch can also be supplied with back strap and mounting hardware as an option. Tighten bolts to about 12 - 15 ft.-lb.

Deadend conductors (if required) to deadending holes in switch base using your utility's normal practices.

Wire brush terminal pads and apply a coating of oxidation inhibitor such as Chance z.l.n. (100 or 200).

If the switch has been supplied with by-pass studs assemble them between terminal pad and terminal. See **Figure 4**.

Wirebrush connector mounting surfaces and attach to terminal pads as shown in **Figure 4** with hardware facing away from insulators. Wire brush electrical conductors and apply a coating of oxidation inhibitor such as Chance z.l.n. (100 or 200) before inserting into connector. Tighten connector hardware to about 30 foot-pounds (1/2" hardware).

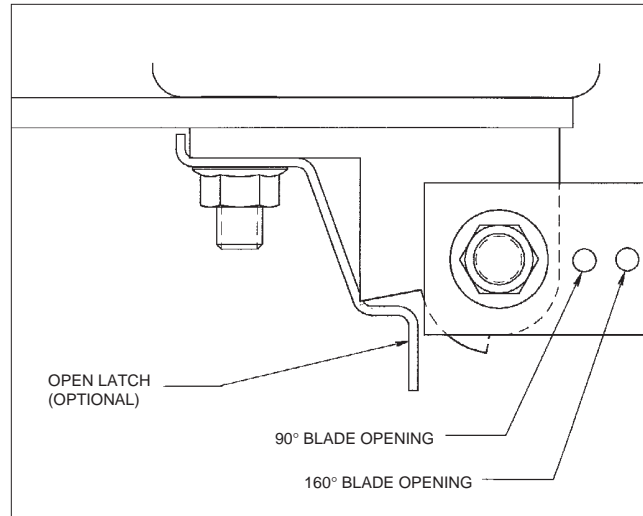

Figure 3

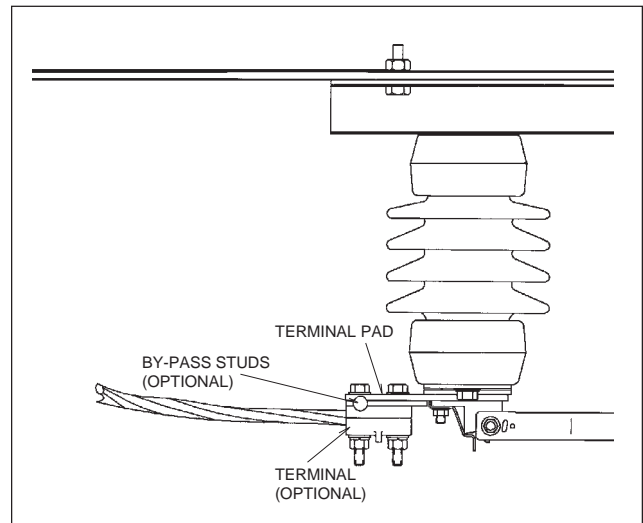

Figure 4

OPERATION

⚠ WARNING

Only qualified personnel should operate a disconnect switch. Such personnel should wear appropriate protective equipment such as rubber gloves, hard hat, safety glasses, etc., in accordance with established utility and safety practices.

To close the M3 disconnect switch, place the hookstick in the pull ring on the blade and rotate the blade to an intermediate position as shown in **Figure 5**. Look away from the switch. Quickly and firmly drive the switch blade to the closed position. Carefully remove the hookstick from the pull ring to avoid opening the switch.

The M3 switch is properly closed when the blade hook is fully engaged with the latch portion of the blade stop as shown in **Figure 6**.

To open the M3 disconnect switch, place the hookstick in the pull ring as shown in **Figure 7**.

Look away from the switch. Quickly and firmly pull down and towards the hinge end of the switch at about a 45° angle. Once the switch blade is open, complete the blade travel to its stop position. Carefully remove the hookstick from the pull ring.

⚠ WARNING

Do not attempt to open a disconnect switch to interrupt load current. An arc started by opening a disconnect switch under load could cause injury to personnel or damage to equipment.

All Chance M3 disconnect switches include loadbreak hooks for use with a loadbreak tool. To open the switch under load, use only an approved loadbreak tool or device designed for use with switches. Follow the instructions provided with such tools.

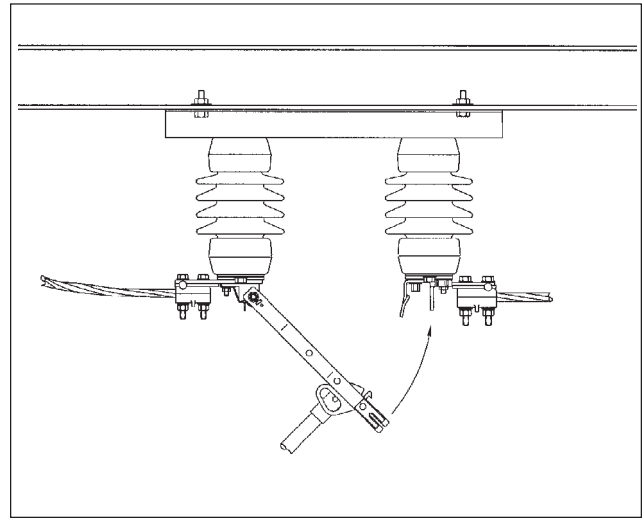

Figure 5

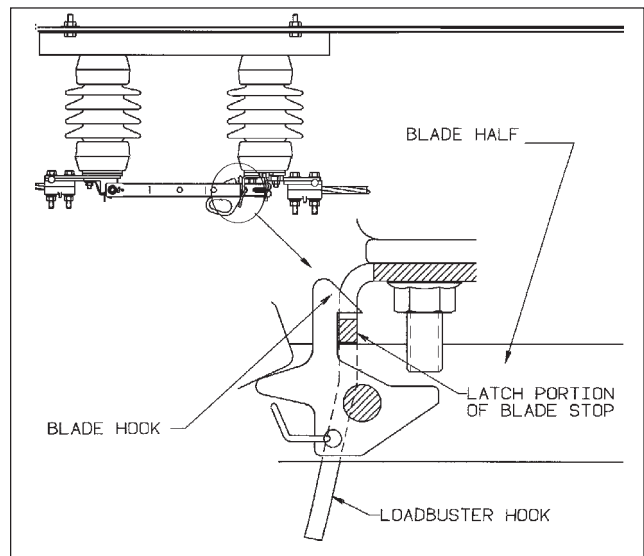

Figure 6

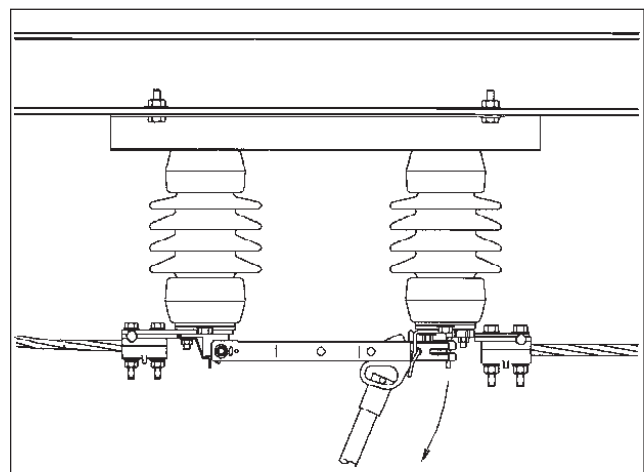

Figure 7

MAINTENANCE

The Chance M3 disconnect switch should require little maintenance. Following a program of periodic inspection and maintenance will prolong the life of the M3 switch.

- Operate the switch periodically to clean contact surfaces and to free moving parts.
- Check for burned or pitted contacts and replace if necessary.
- Check hinge bolt for looseness, and if loose, torque to 40-in.-lb. and apply Loctite®-271 to bolt threads.
- Inspect all blade rivets for tightness and replace blade if loose.
- Inspect mounting hardware and tighten as needed (12 - 15- ft.lb.)
- Replace any broken or cracked insulators and clean or replace if heavily contaminated.

For additional recommendations, refer to ANSI C37.35 "IEEE Guide for the Application, Installation, Operation, and Maintenance of High Voltage Air Disconnecting and Load Interrupter Switches."

